

harman/kardon

# AVR140

6 X 40W 6.1 CHANNEL A/V RECEIVER

## PRELIMINARY SERVICE MANUAL



### CONTENTS

ESD WARNING.....	2	DISASSEMBLY.....	22
LEAKAGE TESTING.....	3	UNIT EXPLODED VIEW.....	23
BASIC SPECIFICATIONS.....	4	EXPLODED VIEW PARTS LIST.....	24
PACKAGING.....	5	AMP BIAS ADJUSTMENT.....	25
FRONT PANEL CONTROLS.....	6	TECH TIP HK2003-01.....	26
REAR PANEL CONNECTIONS.....	8	BLOCK DIAGRAM.....	27
REMOTE CONTROL FUNCTIONS.....	10	PCB DRAWINGS.....	28
CONNECTIONS.....	13	ELECTRICAL PARTS LIST.....	34
OPERATION.....	15	SEMICONDUCTOR PINOUTS.....	68
TROUBLESHOOTING GUIDE.....	21	SCHEMATICS.....	152
PROCESSOR RESET.....	21	WIRING DIAGRAM.....	159

harman/kardon, Inc.  
250 Crossways Park Dr.  
Woodbury, New York 11797

---

## ELECTROSTATICALLY SENSITIVE (ES) DEVICES

Some semiconductor (solid state) devices can be damaged easily by static electricity. Such components commonly are called Electrostatically Sensitive (ES) Devices. Examples of typical ES devices are integrated circuits and some field effect transistors and semiconductor "chip" components.

The following techniques should be used to help reduce the incidence of component damage caused by static electricity.



1. Immediately before handling any semiconductor component or semiconductor-equipped assembly, drain off any electrostatic charge on your body by touching a known earth ground. Alternatively, obtain and wear a commercially available discharging wrist strap device, which should be removed for potential shock reasons prior to applying power to the unit under test.
2. After removing an electrical assembly equipped with ES devices, place the assembly on a conductive surface such as aluminum foil, to prevent electrostatic charge build-up or exposure of the assembly.
3. Use only a grounded-tip soldering iron to solder or unsolder ES devices.
4. Use only an anti-static solder removal device. Some solder removal devices not classified as "anti-static" can generate electrical charges sufficient to damage ES devices.
5. Do not use freon-propelled chemicals. These can generate electrical charge sufficient to damage ES devices.
6. Do not remove a replacement ES device from its protective package until immediately before you are ready to install it. (Most replacement ES devices are packaged with leads electrically shorted together by conductive foam, aluminum foil or comparable conductive material.)
7. Immediately before removing the protective material from the leads of a replacement ES device, touch the protective material to the chassis or circuit assembly into which the device will be installed.

**CAUTION** : Be sure no power is applied to the chassis or circuit, and observe all other safety precautions.

8. Minimize bodily motions when handling unpackaged replacement ES devices. (Otherwise harmless motion such as the brushing together of your clothes fabric or the lifting of your foot from a carpeted floor can generate static electricity sufficient to damage an ES devices.

## PRODUCT SAFETY NOTICE

Each precaution in this manual should be followed during servicing.

Components identified with the IEC symbol  in the parts list are special significance to safety. When replacing a component identified with , use only the replacement parts designated, or parts with the same ratings or resistance, wattage, or voltage that are designated in the parts list in this manual. Leakage-current or resistance measurements must be made to determine that exposed parts are acceptably insulated from the supply circuit before returning the product to the customer.

## SAFETY PRECAUTIONS

The following check should be performed for the continued protection of the customer and service technician.

### LEAKAGE CURRENT CHECK

Measure leakage current to a known earth ground (water pipe, conduit, etc.) by connecting a leakage current tester between the earth ground and all exposed metal parts of the appliance (input/output terminals, screwheads, metal overlays, control shaft, etc.). Plug the AC line cord of the appliance directly into a 120V AC 60Hz outlet and turn the AC power switch on. Any current measured must not exceed 0.5mA.

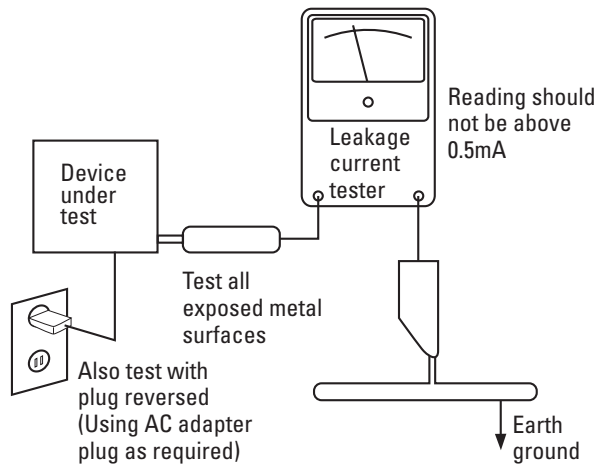

### AC Leakage Test

**ANY MEASUREMENTS NOT WITHIN THE LIMITS OUTLINED ABOVE ARE INDICATIVE OF A POTENTIAL SHOCK HAZARD AND MUST BE CORRECTED BEFORE RETURNING THE APPLIANCE TO THE CUSTOMER.**

# AVR 140 TECHNICAL SPECIFICATIONS

## Audio Section

Stereo Mode

Continuous Average Power (FTC)

50 Watts per channel, 20Hz–20kHz,  
@ <0.07% THD, both channels driven into 8 ohms

Six-Channel Surround Modes

Power per Individual Channel

Front L&R channels:  
40 Watts per channel  
@ <0.07% THD, 20Hz–20kHz into 8 ohms

Center channel:  
40 Watts @ <0.07% THD, 20Hz–20kHz into 8 ohms

Surround (L & R Side, Back) channels:  
40 Watts per channel

@ <0.07% THD, 20Hz–20kHz into 8 ohms

Input Sensitivity/Impedance

Linear (High-Level) 200mV/47k ohms

Signal-to-Noise Ratio (IHF-A) 100dB

Surround System Adjacent Channel Separation

Pro Logic I/II 40dB

Dolby Digital (AC-3) 55dB

DTS 55dB

Frequency Response

@ 1W (+0dB, –3dB) 10Hz –130kHz

High Instantaneous

Current Capability (HCC) ±25 Amps

Transient Intermodulation

Distortion (TIM) Unmeasurable

Slew Rate

40V/μsec

## FM Tuner Section

Frequency Range 87.5–108.0MHz

Usable Sensitivity IHF 1.3μV/13.2dB

Signal-to-Noise Ratio Mono/Stereo 70/68dB

Distortion Mono/Stereo 0.2/0.3%

Stereo Separation 40dB @ 1kHz

Selectivity ±400kHz, 70dB

Image Rejection 80dB

IF Rejection 90dB

## AM Tuner Section

Frequency Range 520–1720kHz

Signal-to-Noise Ratio 45dB

Usable Sensitivity Loop 500μV

Distortion 1kHz, 50% Mod 0.8%

Selectivity ±10kHz, 30dB

## Video Section

Television Format NTSC

Input Level/Impedance 1Vp-p/75 ohms

Output Level/Impedance 1Vp-p/75 ohms

Video Frequency Response  
(Composite and S-Video) 10Hz–8MHz (–3dB)

Video Frequency Response  
(Component Video) 10Hz–50MHz (–3dB)

## General

Power Requirement AC 120V/60Hz

Power Consumption 65W idle, 540W maximum  
(6 channels driven)

Dimensions

Width (Product) 17.3 inches (440mm) (Shipping) 21.5 inches (545mm)

Height 6.6 inches (168mm) 9.9 inches (251mm)

Depth 15 inches (382mm) 17.9 inches (455mm)

Weight (Product) 24.4 lb (11.1kg)

(Shipping) 29.3 lb (13.3kg)

Depth measurement includes knobs, buttons and terminal connections.

Height measurement includes feet and chassis.

All features and specifications are subject to change without notice.

Harman Kardon, Power for the Digital Revolution, The Bridge, **Bridge** and Logic 7 are registered trademarks of Harman International Industries, Incorporated.

\*Manufactured under license from Dolby Laboratories. "Dolby," "Pro Logic" and the Double-D symbol are trademarks of Dolby Laboratories.

DTS, DTS Surround, DTS-ES and DTS Neo:6 are registered trademarks of Digital Theater Systems, Inc.

VMAx is a registered trademark of Harman International Industries, Incorporated, and is an implementation of Cooper Bauck Transaural Stereo under patent license.

Cirrus is a registered trademark of Cirrus Logic, Inc.

SACD is a trademark of Sony Electronics, Inc.

Apple and iPod are registered trademarks of Apple Computer, Inc.

Please register your product on our Web site at [www.harmankardon.com](http://www.harmankardon.com). Note: You'll need your serial number.

At the same time you can choose to be notified about our new products and/or special promotions.



## 1. Instruction manual ass'y - Accessories

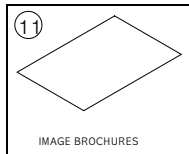
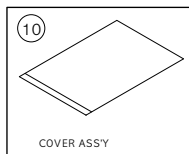
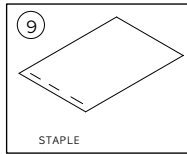
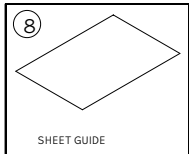
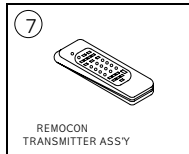
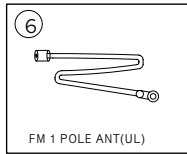
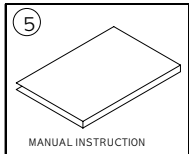
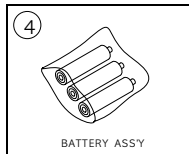
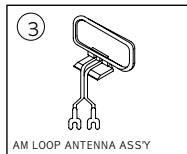
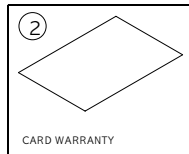
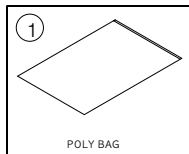

NO	DESCRIPTION	PARTS NO.	Q.ty
1	POLY BAG		1
2	CARD WARRANTY	CQE1A172X	1
3	AM LOOP ANTENNA	CSA1A027Z	1
4	BATTERY		3
5	INSTRUCTION MANUAL	CQX1A1025Z	1
6	FM 1 POL ANT(UL)	CSA1A019Z	1
7	REMOCCON TRANSMITTER ASS'Y	HARTAVR140	1
8	SHEET GUIDE(QUICK START GUIDE)	CQE1A258Z	1
9	STAPLE		3
10	COVER ASS'Y	CGRAVR130ZA	1
1	COVER A	CGR1A331M7H43	1
2	COVER B	CGR1A332M7H43	1
3	SHEET,FRONT COVER	CQE1A219Z	1
4	PAD, COVER	CPS1A676	1
5	BAG,POLY		1
11	IMAGE BROCHURES	HQE1A273Z	1

## 2. Package Drawing

AVR140

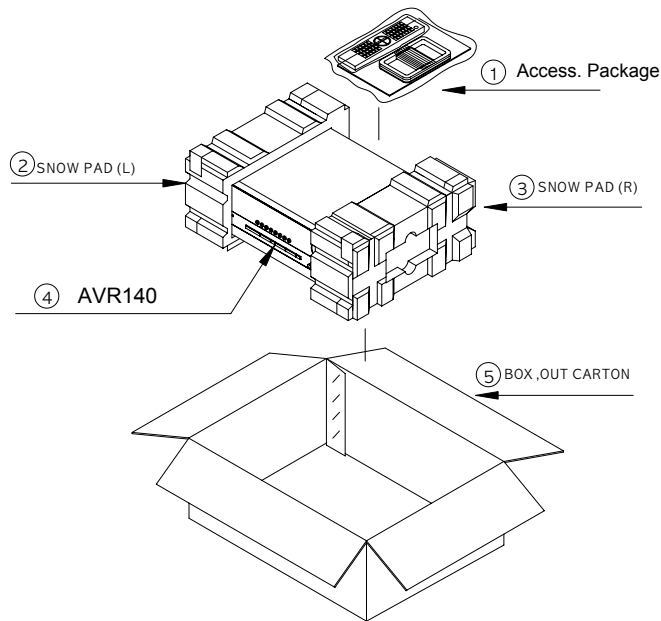

NO	DESCRIPTION	PARTS NO.	Q.ty
1	Access. Package		1
2	SNOW,PAD(L)	CPS5A564	1
3	SNOW,PAD(R)	CPS5A565	1
4	AVR140	AVR 140	1
5	BOX,OUT CARTON	CPG1A797Z	1

## FRONT - PANEL CONTROLS

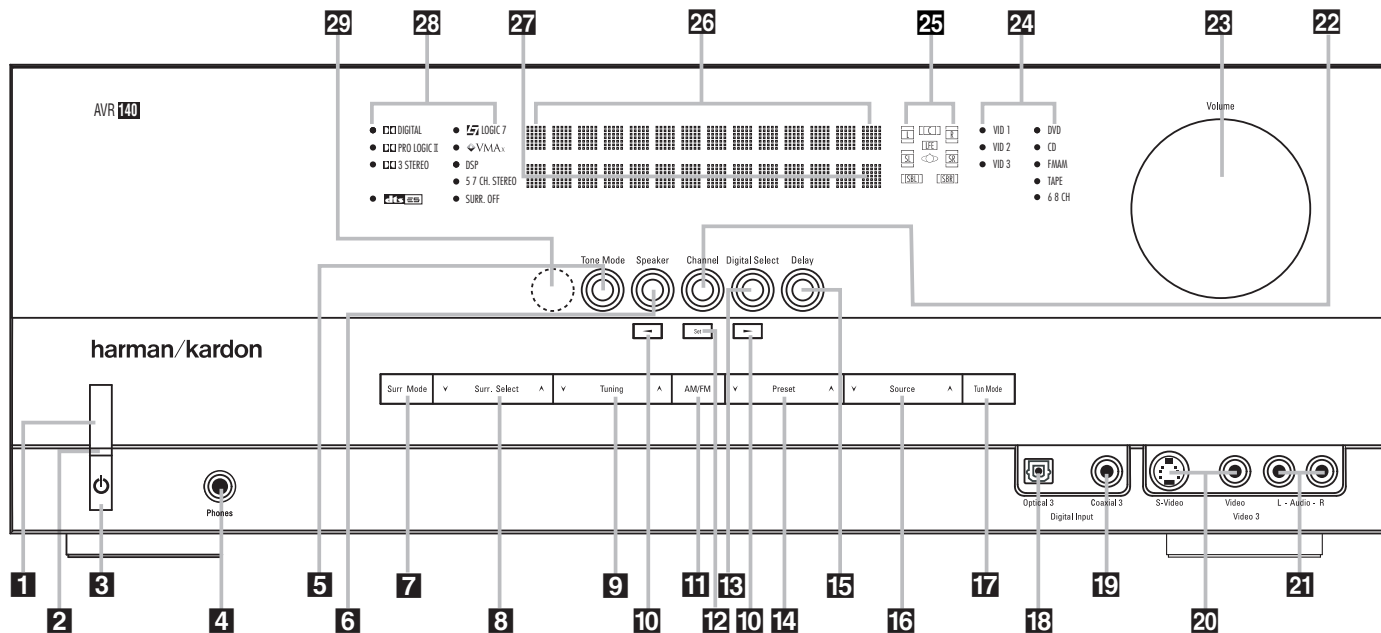

**NOTE:** To make it easier to follow the instructions that refer to this illustration, a larger copy may be downloaded from the Product Support section for this product at [www.harmankardon.com](http://www.harmankardon.com).

- 1** Main Power Switch
- 2** Power Indicator
- 3** Standby/On Switch
- 4** Headphone Jack
- 5** Tone Mode
- 6** Speaker Selector
- 7** Surround Mode Group Selector
- 8** Surround Mode Selector
- 9** Tuning Selector
- 10** ◀▶ Buttons
- 11** Tuner Band Selector
- 12** Set Button
- 13** Digital Input Selector
- 14** Preset Station Selector
- 15** Delay Adjust Selector
- 16** Input Source Selector
- 17** Tuner Mode Selector
- 18** Optical 3 Digital Audio Input
- 19** Coaxial 3 Digital Audio Input
- 20** Video 3 Video Input Jacks
- 21** Video 3 Audio Input Jacks
- 22** Channel Adjust Selector
- 23** Volume Control
- 24** Input Indicators
- 25** Speaker/Channel Input Indicators
- 26** Upper Display Line
- 27** Lower Display Line
- 28** Surround Mode Indicators
- 29** Remote Sensor Window

**1 Main Power Switch:** Press this button to apply power to the AVR 140. When the switch is pressed in, the unit is in a Standby mode, as indicated by the amber LED **2** above the **Standby/On Switch 3**. This button **MUST** be pressed in to operate the unit. To turn the unit off and prevent the use of the remote control, this switch should be pressed until it pops out from the front panel and the word "OFF" is seen at the top of the switch.

**NOTE:** This switch is normally left in the "ON" position.

**2 Power Indicator:** This LED lights amber when the unit is in the Standby mode to signal that the AVR is ready to be turned on. When the unit is in operation, the indicator is blue.

**3 Standby/On Switch:** When the **Main Power Switch 1** is "ON," press this button to turn on the AVR 140; press it again to turn the unit off. The **Power Indicator 3** turns blue when the unit is on.

**4 Headphone Jack:** This jack may be used to listen to the AVR 140's output through a pair of headphones. The speakers will automatically be turned off when the headphone jack is in use.

**5 Tone Mode:** This button controls the tone mode settings, enabling adjustment of the bass and treble boost/cut. You may also use it to take the tone controls out of the signal path completely for "flat" response. The first press of the button displays a **TONE IN** message in the **Lower Display Line 27** and in the on-screen display. To take the controls out of the signal path, press either of the **◀▶ Buttons 10** until the display reads **TONE OUT**.

To change the bass or treble settings, make sure that **TONE IN** appears in the **Lower Display Line 27** or press either of the **◀▶ Buttons 10** until it does. Press the **Tone Mode Button 5** until the desired option of **TREBLE MODE** or **BASS MODE** appears in the **Lower Display Line 27** and in the on-screen display and then press either of the **◀▶ Buttons 10** to enter the desired boost or cut setting.

Both treble and bass contours may be boosted or cut by up to + or -10dB in increments of 2dB. See pages 17 and 25 for more information on the tone controls.

**NOTE:** The AVR 140 is not equipped with a traditional Balance control. When listening to two-channel materials, if you wish to adjust the stereo image, you may use the **Channel Adjust Selector 22** to increase or decrease the level of the left front channel by up to + or -10dB, and then to decrease or increase the right front channel by the corresponding amount. However, when listening to surround materials and most two-channel materials, it is recommended that you leave these settings at the results obtained during the configuration process described on pages 15 through 24.

**6 Speaker Selector:** Press this button to begin the process of configuring the unit to match the type of speakers used in your listening room. (See pages 20-22 for more information on speaker setup and configuration.)

# FRONT - PANEL CONTROLS

**7 Surround Mode Group Selector:** Press this button to select the top-level group of surround modes. Each press of the button will select the current or last used mode in each of the surround mode groups (e.g., Dolby, DTS, DTS Neo:6, Logic 7, DSP, Stereo). When the button is pressed so that the name of the surround mode group appears in the on-screen display and in the **Lower Display Line 27**, press the **Surround Mode Selector 8** to cycle through the individual modes available. For example, press this button to select Dolby modes, and then press the **Surround Mode Selector 8** to choose from the various Dolby mode options.

**8 Surround Mode Selector:** Press this button to select from among the available surround mode options for the mode group selected. The specific modes will vary based on the number of speakers available, the mode group and if the input source is digital or analog. For example, press the **Surround Mode Group Selector 7** to select a main mode grouping such as Dolby or Logic 7, and then press this button to see the specific mode choices available. Note that the digital surround modes, such as Dolby Digital and DTS, may not be accessed unless that type of source signal is present, such as when a DVD movie or television signal programmed in Dolby Digital or DTS surround sound is playing. For more information on surround mode selection, see pages 18 and 26.

**9 Tuning Selector:** Press the left side of the button to tune lower-frequency stations and the right side of the button to tune higher-frequency stations. When the tuner is in the Manual mode, each tap will increase or decrease the frequency by one increment. When the tuner receives a strong enough signal for adequate reception, **MANUAL TUNED** will appear in the on-screen display and the **Lower Display Line 27**. When the tuner is the Auto mode, press the button once, and the tuner will scan for a station with acceptable signal strength. When the next station with a strong signal is tuned the scan will stop and the on-screen display and **Lower Display Line 27** will indicate **AUTO TUNED**. When an FM Stereo station is tuned, the display will read **AUTO ST TUNED**.

To switch back and forth between the Auto and Manual tuning modes, press the **Tuner Mode Selector 17**.

**10 ◀▶ Buttons:** When configuring the AVR 140's settings, use these buttons to select from the available choices.

**11 Tuner Band Selector:** Press this button to turn the AVR on and to select the Tuner as the input. Press it again to switch between the AM and FM frequency bands. (See page 30 for more information on the tuner.)

**12 Set Button:** When making choices during the setup and configuration process, press this button to enter the desired setting into the AVR 140's memory.

**13 Digital Input Selector:** Press this button to select one of the digital audio inputs or the analog audio input for any source. (See pages 26–30 for more information on digital audio.)

**14 Preset Stations Selector:** Press this button to scroll up or down through the list of stations that have been entered into the preset memory. (See page 30 for more information on tuner presets.)

**15 Delay Adjust Selector:** Press this button to begin the steps required to enter delay settings. (See pages 22–23 for more information on delay times.)

**16 Input Source Selector:** Press this button to change the input by scrolling up or down through the list of **Input Indicators 24**.

**17 Tuner Mode Selector:** Press this button to select Auto or Manual tuning. When the button is pressed so that the **AUTO** appears in the **Lower Display Line 27**, the tuner will search for the next station with an acceptable signal when the **Tuning Selector 9 21** is pressed. When the button is pressed so that **MANUAL** appears in the **Lower Display Line 27**, each press of the **Tuning Selector 9 21** will increase the frequency. This button may also be used to switch between Stereo and Mono modes for FM radio reception. When weak reception is encountered, press the button so that **MANUAL** appears in the **Lower Display Line 27** and on the on-screen display to switch to Mono reception. Press it again to switch back to Stereo mode. (See page 30 for more information on using the tuner.)

**18 Optical 3 Digital Audio Input:** Connect the optical digital audio output of an audio or video product to this jack. When the input is not in use, the built-in shutter will close to avoid dust contamination that might degrade future performance.

**19 Coaxial 3 Digital Audio Input:** This jack is used for connection to the output of portable audio devices, video game consoles or other products that have a coax digital audio jack.

**20 Video 3 Video Input Jacks:** These jacks may be used for temporary connection to the composite or S-video output of video games, camcorders or other portable video products. You may make a connection to either jack at any time, but not to both simultaneously.

**21 Video 3 Audio Input Jacks:** These audio jacks may be used for temporary connection to video games or portable audio/video products such as camcorders and portable audio players.

**22 Channel Adjust Selector:** Press this button to begin the process of trimming the channel output levels using an external audio source. (For more information on output level trim adjustment, see page 23.)

**23 Volume Control:** Turn this knob clockwise to increase the volume, counterclockwise to decrease the volume. If the AVR 140 is muted, adjusting the **Volume Control 23 48** will automatically release the unit from the silenced condition.

**24 Input Indicators:** The current selected source will appear as one of these indicators. Note that when the unit is turned on, the entire list of available modes will light briefly, and then revert to normal operation with only the active mode indicator illuminated.

**25 Speaker/Channel Input Indicators:** These indicators are multipurpose, indicating both the speaker type selected for each channel and the incoming data-signal configuration. The left, center, right, right surround and left surround speaker indicators are composed of three boxes, while the subwoofer is a single box. The center box lights when a "small" speaker is selected, and the two outer boxes light when "large" speakers are selected. When none of the boxes are lit for the center, surround or subwoofer channels, no speaker has been assigned that position. (See page 20 for more information on configuring speakers.)

The letters inside each box display the active input channels. For standard analog sources, only the L and R will light, indicating a stereo input. For a digital source, the indicators will light to display the channels being received at the digital input. When the letters flash, the digital input has been interrupted. (See page 29 for more information on the Channel Indicators.)

**26 Upper Display Line:** Depending on the unit's status, a variety of messages will appear here. In normal operation, this line will show current input source and which analog or digital input is in use. When the tuner is the input, this line will identify the station as AM or FM and show the frequency and preset number, if any.

**27 Lower Display Line:** Depending on the unit's status, a variety of messages will appear here. In normal operation, the current surround mode will show here.

**28 Surround Mode Indicators:** The current selected surround mode will appear as one of these indicators. Note that when the unit is turned on, the entire list of available modes will light briefly, and then revert to normal operation with only the active mode indicator illuminated.

**29 Remote Sensor Window:** The sensor behind this window receives infrared signals from the remote control. Aim the remote at this area and do not block or cover it.

# REAR-PANEL CONNECTIONS

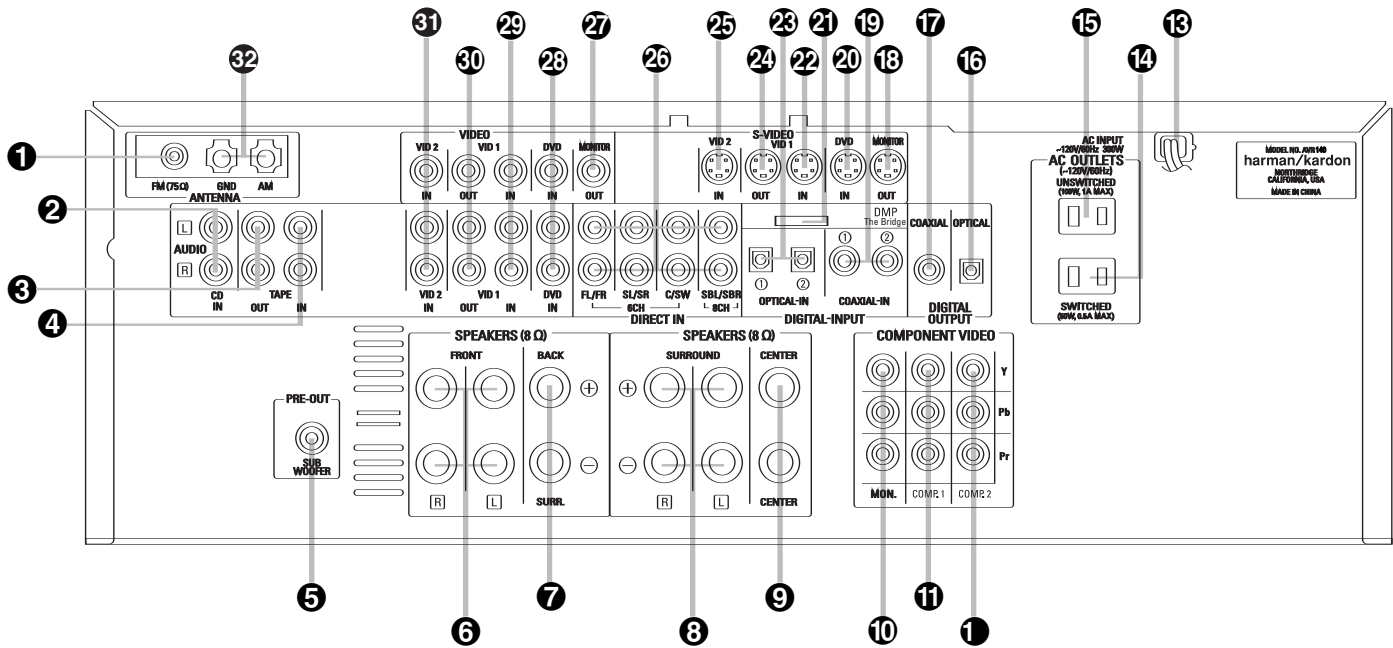

**NOTE:** To make it easier to follow the instructions that refer to this illustration, a larger copy may be downloaded from the Product Support section for this product at [www.harmankardon.com](http://www.harmankardon.com).

- 1 FM Antenna Jack
- 2 CD Audio Inputs
- 3 Tape Outputs
- 4 Tape Inputs
- 5 Subwoofer Output
- 6 Front Speaker Outputs
- 7 Surround Back Speaker Outputs
- 8 Surround Speaker Outputs
- 9 Center Speaker Outputs
- 10 Component Video Monitor Outputs
- 11 Component Video 1 Inputs
- 12 Component Video 2 Inputs
- 13 AC Power Cord
- 14 Switched AC Accessory Outlet
- 15 Unswitched AC Accessory Outlet
- 16 Optical Digital Audio Output
- 17 Coaxial Digital Audio Output
- 18 S-Video Monitor Output
- 19 Coaxial Digital Audio Inputs
- 20 DVD S-Video Input
- 21 Bridge-DMP Connector
- 22 Video 1 S-Video Input
- 23 Optical Digital Audio Inputs
- 24 Video 1 S-Video Output
- 25 Video 2 S-Video Input
- 26 6/8-Channel Direct Inputs
- 27 Video Monitor Output
- 28 DVD Audio/Video Inputs
- 29 Video 1 Audio/Video Inputs
- 30 Video 1 Audio/Video Outputs
- 31 Video 2 Audio/Video Inputs
- 32 AM Antenna Terminals

**NOTE:** To assist in making the correct connections for multichannel input, output and speaker connections, all connection jacks and terminals are color-coded in conformance with the CEA standards as follows:

Front Left: White

Front Right: Red  
 Center: Green  
 Surround Left: Blue  
 Surround Right: Gray  
 Surround Back Left: Brown  
 Surround Back Right: Tan

Subwoofer: Purple  
 Coaxial Digital Audio: Orange  
 Composite Video: Yellow  
 Component Video "Y": Green  
 Component Video "Pr": Red  
 Component Video "Pb": Blue

- 1 FM Antenna Jack:** Connect the supplied indoor (or an optional external) FM antenna to this terminal.
- 2 CD Audio Inputs:** Connect these jacks to the analog audio outputs of a compact disc player or CD changer.
- 3 Tape Outputs:** Connect these jacks to the RECORD/INPUT jacks of an audio recorder.
- 4 Tape Inputs:** Connect these jacks to the PLAY/OUT jacks of an audio recorder.

- 5 Subwoofer Output:** Connect this jack to the line-level input of a powered subwoofer. If an external subwoofer amplifier is used, connect this jack to the subwoofer amplifier input.
- 6 Front Speaker Outputs:** Connect these outputs to the matching + or – terminals on your left and right speakers. When making speaker connections always make certain to maintain correct polarity by connecting the color-coded (white for front left and red for front right) (+) terminals on the AVR 140 to the red (+)

terminals on the speakers and the black (–) terminals on the AVR 140 to the black (–) terminals on the speakers. See page 12 for more information on speaker polarity.

- 7 Surround Back Speaker Outputs:** These speaker terminals are normally used to power the surround back speaker in a 6.1-channel system. Connect these outputs to the matching + and – terminals on your surround back channel speaker. In conformance with the CEA color-code specification, the brown ter-

## REAR-PANEL CONNECTIONS

terminal is the positive, or "+," terminal that should be connected to the red (+) terminal on the Surround Back speaker with older color-coding. Connect the black (-) terminal on the AVR to the matching black negative (-) terminal on the surround back speaker. (See page 12 for more information on speaker polarity.)

**8 Surround Speaker Outputs:** Connect these outputs to the matching + and - terminals on your surround channel speakers. In conformance with the CEA color-code specification, the blue terminal is the positive, or "+," terminal that should be connected to the red (+) terminal on the Surround Left speaker with older color-coding, while the gray terminal should be connected to the red (+) terminal on the Surround Right speaker with the older color-coding. Connect the black (-) terminal on the AVR to the matching black negative (-) terminals for each surround speaker. (See page 12 for more information on speaker polarity.)

**9 Center Speaker Outputs:** Connect these outputs to the matching + and - terminals on your center channel speaker. In conformance with the CEA color-code specification, the green terminal is the positive, or "+," terminal that should be connected to the red (+) terminal on speakers with the older color-coding. Connect the black (-) terminal on the AVR to the black (-) terminal on your speaker. (See page 12 for more information on speaker polarity.)

**10 Component Video Monitor Outputs:** Connect these outputs to the component video inputs of a video projector or monitor. When a source connected to one of the **Component Video Inputs 11** is selected, the signal will be sent to these jacks.

**11 Component Video 1 Inputs:** Connect the Y/Pr/Pb component video outputs of a DVD player, HDTV set-top converter, satellite receiver or other video source device with component video outputs to these jacks.

**1 Component Video 2 Inputs:** Connect the Y/Pr/Pb component video outputs of a DVD player, HDTV set-top converter, satellite receiver or other video source device with component video outputs to these jacks.

See page 17 for information on assigning the **Component Video 1 and 2 Inputs 11** to the appropriate source inputs.

**13 AC Power Cord:** Connect the AC power cord to a non-switched AC wall outlet.

**14 Switched AC Accessory Outlet:** These outlets may be used to power any device you wish to have turned on when the AVR 140 is turned on.

**15 Unswitched AC Accessory Outlet:** This outlet may be used to power any AC device. The power will remain on at this outlet regardless of whether the AVR 140 is on or off.

**NOTE:** The total power consumption of all devices connected to the accessory outlets should not exceed 100 watts.

**16 Optical Digital Audio Output:** Connect this jack to the optical digital input connector on a CD-R/RW, MiniDisc or other digital recorder.

**17 Coaxial Digital Audio Output:** Connect this jack to the coaxial digital input of a CD-R/RW, MiniDisc or other digital recorder.

**18 S-Video Monitor Output:** If any of the input sources used in your system have S-video connections to the AVR, connect this jack to the S-video input on your television, projector or other video display.

**19 Coaxial Digital Audio Inputs:** Connect the coax digital output from a DVD player, HDTV receiver, LD player or CD player to these jacks. The signal may be a Dolby Digital signal, DTS signal or a standard PCM digital source. Do not connect the RF digital output of an LD player to these jacks.

**20 DVD S-Video Input:** Connect the S-video output of a DVD player or other video source to this jack.

**21 Bridge Digital Media Player (DMP) Connector:** With the AVR 140 turned off, connect one end of the optional Harman Kardon **Bridge** to this proprietary connector, and the other to your compatible Apple iPod. When the Digital Media Player source is selected, you may view your iPod's control and navigation messages on your video display (if one is connected to one of the **Video Monitor Outputs 18**), and in the **Upper and Lower Display Lines 26**. You may navigate the iPod and select tracks for playback using the **▲/▼/◀▶ Buttons 14**, the **Set Button 16** and **Transport Controls 26** on your AVR remote. See page 30 for more information.

**22 Video 1 S-Video Input:** If the product connected to the **Video 1 Audio Inputs 29** has S-video capability, connect this jack to the PLAY/OUT S-video jack on that unit and then make certain that the **S-Video Monitor Output 18** is connected as described above.

**23 Optical Digital Audio Inputs:** Connect the optical digital output from a DVD player, HDTV receiver, LD player or CD player to these jacks. The signal may be a Dolby Digital signal, a DTS signal or a standard PCM digital source.

**24 Video 1 S-Video Output:** If the product connected to the **Video 1 Audio/Video Outputs 30** has S-video

capability, connect this jack to the REC/IN S-video jack on that unit.

**25 Video 2 S-Video Input:** If the product connected to the **Video 2 Audio/Video Inputs 31** has S-video capability, connect this jack to the PLAY/OUT S-video jack on that unit and then make certain that the **S-Video Monitor Output 18** is connected as described above.

**26 6/8-Channel Direct Inputs:** These jacks are used for connection to source devices such as DVD-Audio or SACD™ players with discrete analog outputs. Depending on the source device in use, all eight jacks may be used, though in many cases only connections to the front left/right, center, surround left/right and LFE (subwoofer input) jacks will be used for standard 5.1 audio signals.

**27 Video Monitor Output:** Connect this jack to the composite video input of a TV monitor or video projector to view the on-screen menus and the output of a standard video source.

**28 DVD Audio/Video Inputs:** Connect the composite video and L/R analog audio outputs of a DVD player or other video source to these jacks.

**29 Video 1 Audio/Video Inputs:** Connect the composite video and L/R analog audio PLAY/OUT jacks of a VCR or other video source to these jacks.

**30 Video 1 Audio/Video Outputs:** Connect the composite video and L/R analog audio REC/IN jacks of a VCR or other video recording device such as a DVD recorder or PVR to these jacks.

**31 Video 2 Audio/Video Inputs:** Connect the composite video and L/R analog audio PLAY/OUT jacks of a cable television box or other video source to these jacks.

**32 AM Antenna Terminals:** Connect the AM loop antenna supplied with the receiver to these terminals. If an external AM antenna is used, make connections to the **AM** and **GND** terminals in accordance with the instructions supplied with the antenna.

**NOTE ON VIDEO CONNECTIONS:** When connecting a video source product such as a VCR, DVD player, satellite receiver, cable set-top box, personal video recorder or video game to the AVR 140, you may use either a composite or S-video connection, but not both.

# REMOTE CONTROL FUNCTIONS

- 1 Power Off Button
- 2 IR Transmitter Window
- 3 Program Indicator
- 4 Power On Button
- 5 Input Selectors
- 6 AVR Selector
- 7 AM/FM Tuner Select
- 8 Dim Button
- 9 Test Button
- 10 Sleep Button
- 11 DSP Surround Mode Selector
- 12 Night Mode
- 13 Channel Select Button
- 14 ▲/▼ Buttons
- 15 ◀/▶ Buttons
- 16 Set Button
- 17 Digital Select
- 18 Numeric Keys
- 19 Tuner Mode
- 20 Direct Button
- 21 Tuning Up/Down
- 22 OSD Button
- 23 Dolby Mode Selector
- 24 DTS Digital Mode Selector
- 25 Logic 7 Mode Select Button
- 26 Skip Up/Down Buttons
- 27 Transport Controls
- 28 Stereo Mode Select Button
- 29 DTS Neo:6 Mode Select
- 30 Macro Buttons
- 31 Disc Skip Button
- 32 Preset Up/Down
- 33 Clear Button
- 34 Memory Button
- 35 Delay/Prev. Ch.
- 36 Speaker Select
- 37 Spare Button
- 38 Volume Up/Down
- 39 TV/Video Selector
- 40 **TheBridge** DMP Selector
- 41 6-Channel/8-Channel Direct Input
- 42 Mute

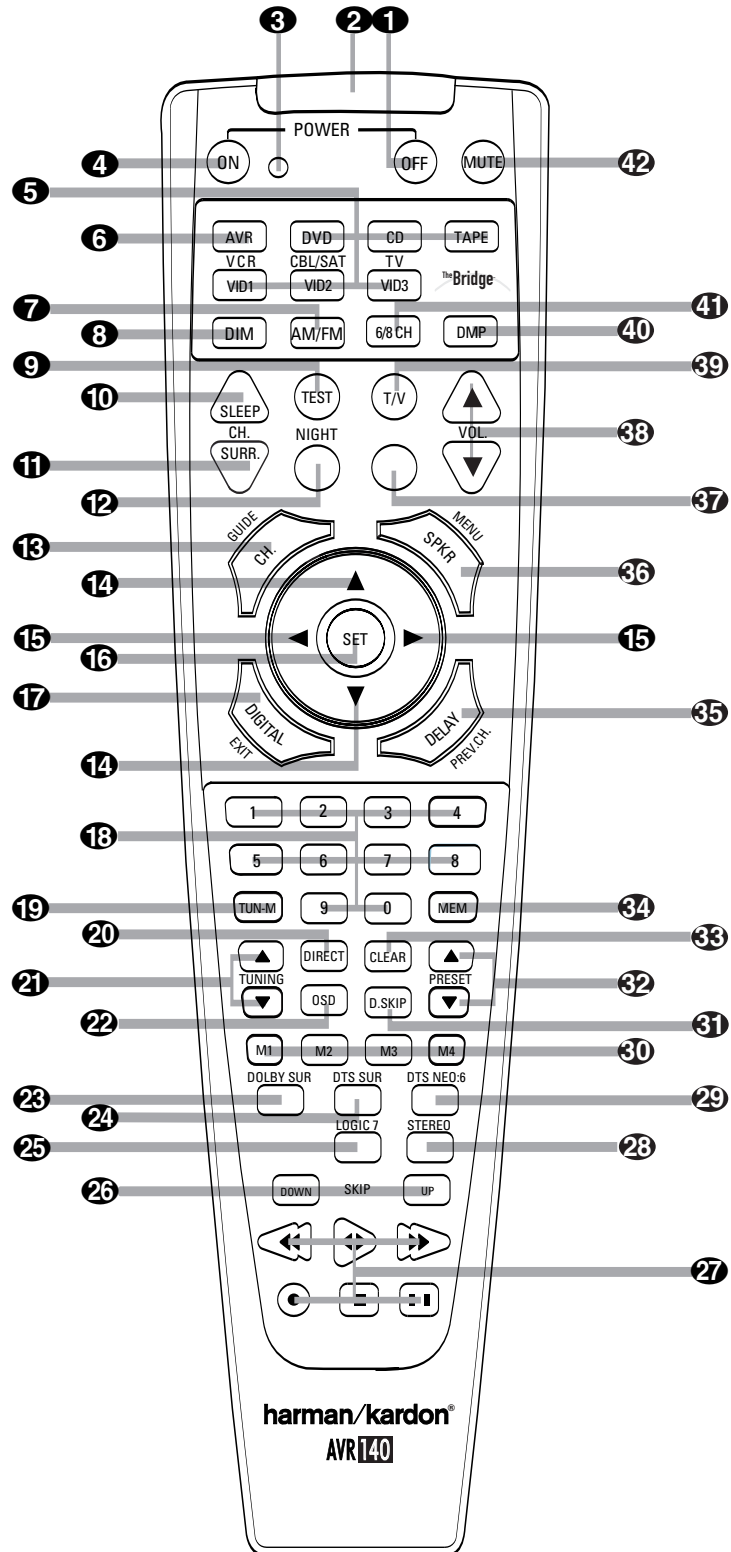

**NOTES:**

- The function names shown here are each button's feature when used with the AVR 140. Most buttons have additional functions when used with other devices. See pages 37–38 for a list of these functions.
- To make it easier to follow the instructions that refer to this illustration, a larger copy may be downloaded from the Product Support section for this product at [www.harmankardon.com](http://www.harmankardon.com).



# REMOTE CONTROL FUNCTIONS

**IMPORTANT NOTE:** The AVR 140's remote may be programmed to control up to seven devices, including the AVR 140. Before using the remote, it is important to remember to press the **Input Selector Button 5** that corresponds to the unit you wish to operate. In addition, the AVR 140's remote is shipped from the factory to operate the AVR 140 and most Harman Kardon CD or DVD players and cassette decks. The remote is also capable of operating a wide variety of other products using the control codes that are part of the remote. Before using the remote with other products, follow the instructions on page 34 to program the proper codes for the products in your system.

It is also important to remember that many of the buttons on the remote take on different functions, depending on the product selected using the Device Control Selectors. The descriptions shown here primarily detail the functions of the remote when it is used to operate the AVR 140. (See pages 35–38 for information about alternate functions for the remote's buttons.)

**1 Power Off Button:** Press this button to place the AVR 140 or a selected device in the Standby mode. Note that this will turn off the main room functions, but if the Multiroom system is activated, it will continue to function.

**2 IR Transmitter Window:** Point this window towards the AVR 140 when pressing buttons on the remote to make certain that infrared commands are properly received.

**3 Program Indicator:** This three-color indicator is used to guide you through the process of programming the remote. (See page 34 for information on programming the remote.)

**4 Power On Button:** Press this button to turn on the power to a device selected by pressing one of the **Input Selectors 5**.

**5 Input Selectors:** Pressing one of these buttons will perform three actions at the same time. First, if the AVR 140 is not turned on, this will power up the unit. Next, it will select the source shown on the button as the input to the AVR 140. Finally, it will change the remote control so that it controls the device selected. After pressing one of these buttons you must press the **AVR Selector Button 6** again to operate the AVR 140's functions with the remote.

**6 AVR Selector:** Pressing this button will switch the remote so that it will operate the AVR 140's functions. If the AVR 140 is in the Standby mode, it will also turn the AVR 140 on.

**7 AM/FM Tuner Select:** Press this button to select the AVR 140's tuner as the listening choice. Pressing

this button when the tuner is already in use will select between the AM and FM bands.

**8 Dim Button:** Press this button to activate the Dimmer function, which reduces the brightness of the front panel display, or turns it off entirely. The first press of the button shows the default state, which is full brightness by indicating **VFD FULL** in the **Lower Display Line 27**. Press the button again within five seconds to reduce the brightness by 50%, as indicated by **VFD HALF** showing in the **Lower Display Line 27**. Press the button again within five seconds and the main display will go completely dark. Note that this setting is temporary, in that regardless of any changes, the display will always return to full brightness when the AVR is turned on. In addition, the **Power Indicator 2** will always remain at full brightness regardless of the setting. This is to remind you that the AVR is still turned on.

**9 Test Button:** Press this button to begin the sequence used to calibrate the AVR 140's output levels. (See pages 23 and 31 for more information on calibrating the AVR 140.)

**10 Sleep Button:** Press this button to place the unit in the Sleep mode. After the time shown in the display, the AVR 140 will automatically go into the Standby mode. Each press of the button changes the time until turn-off in the following order:

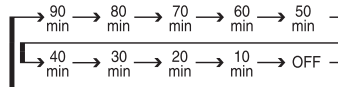

See page 25 for more information on the Sleep Function. This button is also used to change channels on your TV when the TV is selected.

When the AVR 140 remote is being programmed with the codes to operate another device, this button is also used in the "Auto Search" process. (See page 34 for more information on programming the remote.)

**11 DSP Surround Mode Selector:** Press this button to cycle through the DSP, VMaX and Stereo surround modes such as Hall, Theater, VMaX Near and Far, and Surround Off. This button is also used to tune channels when the TV is selected using the device **Input Selector 5**. When the AVR 140 remote is being programmed with the codes of another device, this button is also used in the "Auto Search" process. (See page 34 for more information on programming the remote.)

**12 Night Mode:** Press this button to activate the Night mode. This mode is available in specially encoded digital sources, and it preserves dialogue (center channel) intelligibility at low volume levels.

**13 Channel Select Button:** This button is used to start the process of setting the AVR 140's output levels to

an external source. Once this button is pressed, use the **▲/▼ Buttons 14** to select the channel being adjusted, then press the **Set Button 16**, followed by the **▲/▼ Buttons 14** again, to change the level setting. (See pages 23 and 31 for more information.)

**14 ▲/▼ Buttons:** These multipurpose buttons are used to change or scroll through items in the on-screen menus, make configuration settings such as digital inputs or delay timing, or to select surround modes. When changing a setting, first press the button for the function or setting to be changed (e.g., press the **DSP Surround Mode Selector 11** to select a sound field mode or the **Digital Select Button 17** to change a digital input) and then press one of these buttons to scroll through the list of options or to increase or decrease a setting. The sections in this manual describing the individual features and functions contain specific information on using these buttons for each application.

**15 ◀▶ Buttons:** These buttons are used to change the menu selection or setting during some of the setup procedures for the AVR 140.

**16 Set Button:** This button is used to enter settings into the AVR 140's memory. It is also used in the setup procedures for delay time, speaker configuration and channel output level adjustment.

**17 Digital Select:** Press this button to assign one of the digital inputs **18 19 23** to a source. (See pages 17 and 28 for more information on using digital inputs.)

**18 Numeric Keys:** These buttons serve as a 10-button numeric keypad to enter tuner preset positions. They are also used to select channel numbers when TV, Cable or SAT has been selected on the remote, or to select track numbers on a CD, DVD or LD player, depending on how the remote has been programmed.

**19 Tuner Mode:** Press this button when the tuner is in use to select between automatic tuning and manual tuning. When the button is pressed so that **MANUAL** appears in the **Lower Display Line 27**, pressing the **Tuning Buttons 9 21** will move the frequency up or down in single-step increments. When the FM band is in use, pressing this button when a station's signal is weak will change to monaural reception. (See page 30 for more information.)

**20 Direct Button:** Press this button when the tuner is in use to start the sequence for direct entry of a station's frequency. After pressing the button, simply press the proper **Numeric Keys 18** to select a station. (See page 30 for more information on the tuner.)

**21 Tuning Up/Down:** When the tuner is in use, these buttons will tune up or down through the selected frequency band. If the **Tuner Mode Button 19 17** has

## REMOTE CONTROL FUNCTIONS

been pressed so that **AUTO** appears in the on-screen display and **Lower Display Line 27**, pressing and holding either of the buttons for three seconds will cause the tuner to seek the next station with acceptable signal strength for quality reception. When **MANUAL** appears in the **Lower Display Line 27**, pressing these buttons will tune stations in single-step increments. (See page 30 for more information.)

**22 OSD Button:** Press this button to activate the On-Screen Display (OSD) system used to set up or adjust the AVR 140's parameters.

**23 Dolby Mode Selector:** This button is used to select from among the available Dolby Surround processing modes. Each press of this button will select one of the Dolby Pro Logic II modes or Dolby 3 Stereo. When a Dolby Digital-encoded source is in use, the Dolby Digital mode may also be selected. (See page 27 for the available Dolby surround mode options.)

**24 DTS Digital Mode Selector:** When a DTS-encoded digital source is selected, each press of this button will scroll through the available DTS modes. The specific choice of modes will vary according to whether or not the source material contains DTS-ES 6.1 Discrete encoding. When a DTS source is not in use, this button has no function. (See page 27 for the available DTS digital options.)

**25 Logic 7 Mode Select Button:** Press this button to select from among the available Logic 7 surround modes. (See page 27 for the available Logic 7 options.)

**26 Skip Up/Down Buttons:** These buttons do not have a direct function with the AVR 140, but when used with a compatibly programmed CD or DVD changer they will change to the previous disc in the changer or carousel.

**27 Transport Controls:** These buttons do not have any functions for the AVR 140, but they may be programmed for the forward/reverse play operation of a wide variety of CD or DVD players, and audio or video cassette recorders. (See page 36 for more information.)

**28 Stereo Mode Select Button:** When the button is pressed so that **SURROUND OFF** appears in the **Lower Display Line 27**, with only the **Surr Off Surround Mode Indicator 28** lit, the AVR will operate in a bypass mode with true, fully analog, two-channel left/right stereo mode with no surround processing or bass management, unlike other modes where digital processing is used. When the button is pressed so that **SURROUND OFF** appears in the **Lower Display Line 27**, with both the **DSP and Surr Off Surround Mode Indicators 28** lit, you may enjoy a two-channel presentation of the sound along with the

benefits of bass management. Depending on whether your system is configured for 5.1 or 6.1/7.1 channels, the next press of the button will cause either **5 CH STEREO** or **7 CH STEREO** to appear, and the stereo signal will be routed to all five (or seven) speaker channels. (See page 27 for more information on stereo playback modes.)

**29 DTS Neo:6 Mode Select:** Press this button to select a DTS Neo:6 mode. These modes take a two-channel stereo- or matrix surround-encoded source and create a full five-, six- or seven-channel sound field. (See page 27 for the DTS Neo:6 options.)

**30 Macro Buttons:** Press these buttons to store or recall a "Macro", which is a preprogrammed sequence of commands stored in the remote. (See page 34 for more information on storing and recalling macros.)

**31 Disc Skip Button:** This button has no direct function for the AVR 140 but is most often used to change to the next disc in a CD or DVD player when the remote is programmed for that type of device. (See page 35 for more information on using the remote with products other than the AVR 140.)

**32 Preset Up/Down:** When the tuner is in use, press these buttons to scroll through the stations programmed into the AVR 140's memory. When some source devices, such as CD players, VCRs and cassette decks, are selected using the device **Input Selectors 5**, these buttons may function as Chapter Step or Track Advance.

**33 Clear Button:** Press this button to clear incorrect entries when using the remote to directly enter a radio station's frequency.

**34 Memory Button:** Press this button to enter a radio station into the AVR 140's preset memory. First, tune the desired station, and then press this button. Two underline indicators will flash at the right side of the **Upper Display Line 26**, and within five seconds press the **Numeric Keys 18** for the preset number between 01 and 30 that you wish to assign to the station. (See page 30 for more information.)

**35 Delay/Prev Ch.:** Press this button to begin the process for setting the delay times used by the AVR 140 when processing surround sound. After pressing this button, the delay times are entered by pressing the **Set Button 16** and then using the **▲/▼ Buttons 14** to change the setting. Press the **Set Button 16** again to complete the process. (See page 22 for more information.)

**36 Speaker Select:** Press this button to begin the process of configuring the AVR 140's bass management system for use with the type of speakers used in your system. Once the button has been pressed, use the **▲/▼ Buttons 14** to select the

channel you wish to set up. Press the **Set Button 16** and then select another channel to configure. When all adjustments have been completed, press the **Set Button 16** twice to exit the settings and return to normal operation. (See page 20 for more information.)

**37 Spare Button:** This button has no direct function for the AVR 140, but may be used by other devices.

**38 Volume Up/Down:** Press these buttons to raise or lower the system volume.

**39 TV/Video Selector:** This button does not have a direct function on the AVR 140, but when used with a compatible VCR, DVD or satellite receiver, pressing this button will switch between the output of the device and the external video input.

**40 <sup>TM</sup>Bridge<sup>SM</sup> Digital Media Player (DMP) Selector:** When Harman Kardon's <sup>TM</sup>Bridge<sup>SM</sup> (optional) is connected to <sup>TM</sup>Bridge<sup>SM</sup> **Digital Media Player (DMP) Connector 21** and a compatible Apple® iPod® is docked in <sup>TM</sup>Bridge<sup>SM</sup>, pressing this selector will select the iPod as the audio source input device for the AVR 140. In addition, if a video display is connected to one of the **Video Monitor Outputs 18/27**, the iPod's messages will appear on screen, and in the **Upper and Lower Display Lines 26/27**. The **▲/▼/◀▶ Buttons 14/15**, the **Set Button 16** and the **Transport Controls 27** may be used to navigate the iPod and to operate many functions. See page 30, and the manuals for The Bridge and your iPod for more information.

**41 6-Channel/8-Channel Direct Input:** Press this button to select the device connected to the **6/8-Channel Direct Inputs 26**. (See page 25 for more information.)

**42 Mute:** Press this button to momentarily silence the AVR 140 or TV set being controlled, depending on which device has been selected. When the AVR 140 remote is being programmed to operate another device, this button is pressed with the **Input Selector Button 5** to begin the programming process. (See page 34 for more information on programming the remote.)



# INSTALLATION AND CONNECTIONS

## System Installation

After unpacking the unit, locating it in a place with adequate ventilation and placing it on a solid surface capable of supporting its weight, you will need to make the connections to your audio and video equipment.

**IMPORTANT NOTE:** For your personal safety and to avoid possible damage to your equipment and speakers, it is always a good practice to turn off and unplug the AVR and ALL source equipment from the AC output before making any audio or video system connections.

### Audio Equipment Connections

We recommend that you use high-quality interconnect cables when making connections to source equipment and recorders to preserve the integrity of the signals.

1. Connect the analog outputs of a CD player to the **CD Audio Inputs 2**.

**NOTE:** When the CD player has both fixed and variable audio outputs, it is best to use the fixed output unless you find that the input to the receiver is so low that the sound is noisy, or so high that it is distorted.

2. Connect the analog Play/Out jacks of a cassette deck, MD, CD-R or other audio recorder to the **Tape Input Jacks 4**. Connect the analog Record/In jacks on the recorder to the **Tape Output Jacks 3** on the AVR 140.

3. Connect the output of any digital sources such as a CD or DVD changer or player, advanced video game, a digital satellite receiver, HDTV tuner or digital cable set-top box or the output of a compatible computer sound card to the **Optical and Coaxial Digital Audio Inputs 19, 23, 18, 19**. We recommend connecting the coaxial digital audio output of your DVD player to the **Coax 1 Digital Audio Input 19**, since that digital input is assigned to the DVD source by default.

4. Connect the **Coaxial or Optical Digital Audio Outputs 16, 17** on the rear panel of the AVR 140 to the matching digital input connections on a CD-R or MiniDisc or other digital recorder.

5. Assemble the AM Loop Antenna supplied with the unit so that the tabs at the bottom of the antenna loop snap into the holes in the base. Connect it to the **AM Antenna Terminals 22**.

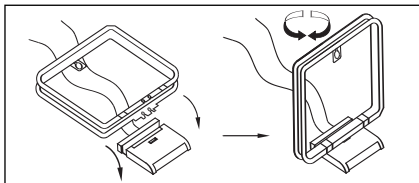

6. Connect the supplied FM antenna to the **FM (75-ohm) Connection 1**. The FM antenna may be an external roof antenna, an inside powered or wire-lead antenna or a connection from a cable TV system. If the antenna or connection uses 300-ohm twin-lead cable, you must use the 300-ohm-to-75-ohm adapter supplied with the unit to make the connection.

7. With the AVR 140 turned off, connect the optional Harman Kardon **Bridge** to **Bridge Digital Media Player (DMP) Connector 21**. Your compatible Apple® iPod® may be docked in **Bridge** when you wish to use it as your audio source device. Video materials stored on the iPod are not able to be viewed using the AVR.

8. Connect the front, center, surround and surround back speaker outputs **6, 7, 8, 9** to the respective speakers.

To ensure that all the audio signals are carried to your speakers without loss of clarity or resolution, we suggest that you use high-quality speaker cable. Many brands of cable are available and the choice of cable may be influenced by the distance between your speakers and the receiver, the type of speakers you use, personal preferences and other factors. Your dealer or installer is a valuable resource to consult in selecting the proper cable.

Regardless of the brand of cable selected, we recommend that you use a cable constructed of multistrand copper with a gauge of 14 or smaller. Remember that in specifying cable, the lower the number, the thicker the cable.

Cable with a gauge of 16 may be used for short runs of less than 10 feet. We do not recommend that you use cables with an AWG equivalent of 18 or higher, due to the power loss and degradation in performance that will occur.

Cables that are run inside walls should have the appropriate markings to indicate listing with UL, CSA or other appropriate testing agency standards. Questions about running cables inside walls should be referred to your installer or a licensed electrician who is familiar with the NEC and/or the applicable local building codes in your area.

When connecting wires to the speakers, observe proper polarity. Note that the positive (+) terminal of each speaker connection may carry a specific color code, as noted on page 7. However, many speakers still use a red terminal for the positive (+) connection. Connect the "negative" or "black" wire to the same terminal on both the receiver and the speaker.

**NOTE:** While most speaker manufacturers adhere to an industry convention of using black terminals for negative and red ones for positive, some may vary

from this configuration. To ensure proper phase and optimal performance, consult the identification plate on your speaker or the speaker's manual to verify polarity. If you do not know the polarity of your speaker, ask your dealer for advice before proceeding, or consult the speaker's manufacturer.

We also recommend that the length of cable used to connect speaker pairs be identical. For example, use the same length piece of cable to connect the front-left and front-right or surround-left and surround-right speakers, even if the speakers are a different distance from the AVR 140.

Note that it is not possible to use the AVR 140 in a 7.1-channel configuration. Any source information that the AVR receives or derives for the surround back left and right channels, e.g. through the **6/8-Channel Direct Inputs 25** or during 7-channel Stereo processing, is combined and outputted to the single-channel **Surround Back Speaker Outputs 7**.

9. Connections to a subwoofer are normally made via a line-level audio connection from the **Subwoofer Output 5** to the line-level input of a subwoofer with a built-in amplifier. When a passive subwoofer is used, the connection first goes to a power amplifier, which will be connected to one or more subwoofers. If you are using a powered subwoofer that does not have line-level input connections, follow the instructions furnished with the speaker for connection information.

10. If an external multichannel audio source with 5.1, 6.1, 7.1 outputs such as an external digital processor/decoder, DVD-Audio or SACD player is used, connect the outputs of that device to the **6/8-Channel Direct Inputs 25**.

### Video Equipment Connections

Video equipment is connected in the same manner as audio components. The use of high-quality interconnect cables is recommended to preserve signal quality.

1. Connect a VCR's, DVD recorder's, personal video recorder's or other video source's audio and video Play/Out jacks to the **Video 1 Audio/Video and/or S-Video Input Jacks 22, 29** on the rear panel. The Audio and Video Record/In jacks on the recorder should be connected to the **Video 1 Audio/Video and/or S-Video Output Jacks 24, 30** on the AVR 140. Although any video device may be connected to these jacks, we recommend connecting your video recorder so that you may take advantage of the fact that the remote control is preprogrammed with video recorder product codes for the Video 1 device.

2. Connect the analog audio and video outputs of a satellite receiver, cable TV converter, television set or any other video source to the **Video 2 Audio/Video**

# INSTALLATION AND CONNECTIONS

and **S-Video Input Jacks 25** 26). Although any video device may be connected to these jacks, we recommend connecting your cable TV converter or satellite receiver so that you may take advantage of the fact that the remote control is preprogrammed with the product codes of these device types for the Video 2 device.

3. Connect the analog audio and video outputs of a television or other video device to the front-panel **Video 3 Audio and Video Input Jacks 20** 21. Although any video or audio device may be connected to these jacks, we recommend connecting your television so that you may take advantage of the fact that the remote control is preprogrammed with television product codes for the Video 3 device. **Important:** If you are only using the television as a display device (i.e., if you receive your television programs through a cable box or satellite receiver), do not connect the TV's outputs to the **Video 3 Audio and Video Input Jacks 20** 21, or to any other inputs on the AVR 140.

4. Connect the analog audio and video outputs of a DVD or laser disc player to the **DVD Audio/Video and S-Video Inputs 20** 23.

5. Connect the digital audio outputs of a DVD player, satellite receiver, cable box or HDTV converter to the appropriate **Optical or Coaxial Digital Inputs 19** 23 18 19. Remember that the DVD source defaults to the **Coaxial 1 Digital Input 19**. All other sources default to their analog inputs, although any source may be assigned to any digital audio input on the receiver.

6. Connect the **Video and/or S-Video Monitor Output 18** 27 jacks on the receiver to the composite or S-video input of your television monitor or video projector.

7. If both your video display monitor and at least one video source device, such as a DVD player or HDTV set-top box, is equipped with component video capability, then you may connect the component video outputs of the device to one of the two **Component Video Inputs 1** 1.

It is recommended that you connect a DVD player or a digital recorder to the **Component Video 1 Inputs 1**, as this input is assigned to the DVD, CD, Tuner and Tape sources by default. Thus, whenever any of these sources is selected, you may view the component video output of the device connected to the **Component Video 1 Inputs 1**, enabling you to view and listen to different sources.

Similarly, it is recommended that you connect any audio/video device, such as a DVD-Audio or SACD player or HDTV set-top box, to the Video 1, Video 2

or Video 3 sources, or the 6-/8-channel direct inputs, as the **Component Video 2 Inputs 1** are assigned to the Video 1, Video 2, Video 3 and 6-/8-channel source audio inputs by default.

However, you may connect any component video source to either set of component video inputs, as they are assignable to any source. You will still need to connect either the analog or digital audio outputs of your component video device to the analog audio inputs corresponding to the source (such as DVD or Video 2 for a cable converter box), or to any of the **Optical or Coaxial Digital audio Inputs 19** 23 18 19.

8. If the component video inputs are used, connect the **Component Video Monitor Outputs 10** to the component video inputs of your TV, projector or display device.

9. If you have a camcorder, video game or other audio/video device that is connected to the AVR on a temporary rather than permanent basis, connect the audio, video and digital audio outputs of that device to the **Front-Panel Inputs 18** 19 20 21. A device connected here is selected as the Video 3 input, and the digital inputs must be assigned to the Video 3 input. (See page 17 for more information on input configuration.)

## VIDEO CONNECTION NOTES:

- When the component video jacks are used, the on-screen menus are not visible and you must switch to the standard composite or S-video input on your TV to view them.
- The AVR 140 will accept either standard composite, S-video or Y/Pr/Pb component video signals. However, it will not convert composite or S signals to component video.
- When connecting a video source to the AVR 140, you may use either composite, component or S-video, but only one type of video may be connected for each device.
- When more than one video format is used, it is necessary to make a separate connection from the AVR to your video display for each format. For example, if both composite and component sources are connected to the AVR 140, both the **Composite** and **Component Video Monitor Outputs 10** 27 must be connected to the appropriate inputs on your video display.

## AC Power Connections

This unit is equipped with two accessory AC outlets. They may be used to power accessory devices, but they should not be used with high-current-draw equip-

ment such as power amplifiers. The total power draw to each outlet may not exceed 100 watts.

The **Switched AC Accessory Outlet 14** will receive power only when the unit is on. This is recommended for devices that have no power switch or a mechanical power switch that may be left in the "ON" position.

**NOTE:** Many audio and video products go into a Standby mode when they are used with switched outlets, and cannot be fully turned on using the outlet alone without a remote control command.

The **Unswitched AC Accessory Outlet 15** will receive power as long as the unit is plugged into a powered AC outlet.

Once the **AC Power Cord 13** is connected, you are almost ready to enjoy the AVR 140's incredible power and fidelity!

## OPERATION

## Basic Operation

Once you have completed the initial setup and configuration of the AVR 140, it is simple to operate and enjoy. The following instructions will help you maximize the enjoyment of your new receiver:

## Turning the AVR 140 On or Off

- When using the AVR 140 for the first time, you must first press the **Main Power Switch 1** on the front panel to turn the unit on. This places the unit in a Standby mode, as indicated by the amber color of the **Power Indicator 2**. Once the unit is in Standby, you may begin a listening session by pressing the **Standby/On Switch 3** on the front panel, or the **Power On Button 4** or **AVR Selector 6** on the remote. The **Power Indicator 2** will turn blue. This will turn the unit on and return it to the input source that was last used. The unit may also be turned on from Standby by pressing any of the **Input Selector Buttons 5 7** on the remote or the **Input Source Selector Button 16** on the front panel.

**NOTE:** After pressing one of the **Input Selector Buttons 5 7** to turn the unit on, press the **AVR Selector 6** to set the remote control to the AVR 140 functions.

To turn the unit off at the end of a listening session, simply press the **Standby/On Switch 3** on the front panel or the **Power Off Button 1** on the remote. Power will be shut off to any equipment plugged into the rear-panel **Switched AC Accessory Outlet 14** and the **Power Indicator 2** will turn amber.

When the remote is used to turn the unit "off" it is actually placing the system in a Standby mode, as indicated by the amber color of the **Power Indicator 2**.

- To program the AVR 140 for automatic turn-off, press the **Sleep Button 10** on the remote. Each press of the button will decrease the time before shut-down in the following sequence:

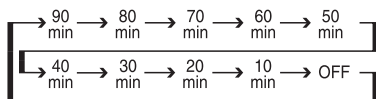

The sleep time will be displayed in the **Lower Display Line 27**. The front-panel display will dim to one-half brightness when the Sleep function is programmed. To view the current sleep time when the sleep function has been activated, press the **Sleep Button 10** once. The display will return to normal brightness, and the time until shutdown will appear in the **Lower Display Line 27**. After a few seconds, the message will disappear and the display will return to half-brightness.

When the programmed sleep time has elapsed, the unit will automatically turn off. To cancel the Sleep

function, press and hold the **Sleep Button 10** as the information display returns to normal brightness; continue to hold the button until the Sleep indicator numbers disappear and the words **SLEEP OFF** appear in the **Lower Display Line 27**.

When you will be away from home for an extended period of time it is always a good idea to completely turn the unit off with the front-panel **Main Power Switch 1**.

**NOTE:** All preset memories are lost if the unit is left turned off by using the **Main Power Switch 1** for more than four weeks.

## Source Selection

- To select a source, press any of the **Input Selector Buttons 5 7 40 41** on the remote.
- The input source may also be changed by pressing the front-panel **Input Source Selector Button 16**. Each press of the button will move the input selection through the list of available inputs.
- As the input is changed, the AVR 140 will automatically switch to the digital input (if selected), component video input, surround mode, output levels and night mode status as well as any speaker configuration settings established by using the **INDEPENDENT** Bass Management setting, that were entered during the configuration process for that source.
- When the input source is changed, the new input name and the digital (or analog) audio input will appear in the **Upper Display Line 26**, and the current surround mode will appear in the **Lower Display Line 27**. The same messages will also appear momentarily in the on-screen display in the lower third of the screen (semi-OSD).
- When an audio source is selected, the last video input used remains routed to the **Video 1 Video** and **S-Video Outputs 24 30** and **Component Video** and **S-Video Monitor Outputs 10 18 27**. This permits you to simultaneously view and listen to different sources.
- The front-panel **Video 3 Inputs 20 21**, **Optical 3 Digital Input 18** or the **Coaxial 3 Digital Input 19** may be used to connect a device such as a video game or camcorder to your home entertainment system on a temporary basis.
- When **Bridge** Digital Media Player (DMP) source is selected, if a compatible Apple iPod device is inserted in an optional Harman Kardon **Bridge**

that is connected to **Bridge** DMP Connector 21 on the rear panel, function messages will appear on any video display connected to the AVR's **Video Monitor Outputs 18 27**, and the remote control may be used to navigate the iPod and access many of its functions. The function messages will also appear in the front-panel display, and the iPod's battery may be charged. See the owner's guides for **Bridge** and your iPod for more information.

## 6-Channel/8-Channel Direct Input

- There are two input choices available for use with sources such as a DVD-Audio or SACD player that are connected to the **6/8-Channel Direct Inputs 26**. Select the appropriate input according to the way your system and source equipment are configured:
  - 6 CH DIRECT** should be used when the SBR and SBL inputs are NOT in use. It is assumed that the input source device has its own internal bass management system. This input passes the input from the source directly through to the volume control without any analog to digital conversion and it mutes the unused input jacks to prevent unwanted noise from interfering with system performance.
  - 8 CH DIRECT** should be used when an input is connected to all eight **8-Channel Direct Inputs 26**. It is assumed that the input source device has its own internal bass management system. This input passes the input from the source directly through to the volume control without any analog-to-digital conversion and it mutes the unused input jacks to prevent unwanted noise from interfering with system performance.

## Volume Control

- Adjust the volume to a comfortable level using the front-panel **Volume Control 23** or remote **Volume Up/Down Buttons 33**.
- To temporarily silence all speaker outputs, press the **Mute Button 42**. This will interrupt the output to all speakers and the headphone jack, but it will not affect any recording or dubbing that may be in progress. When the system is muted, the word **MUTE** will flash in the **Upper Display Line 26**. Press the **Mute Button 42** again to return to normal operation.
- You may adjust the bass and treble tone controls at any point during a listening session by pressing the **Tone Mode Button 5** until **TONE IN** appears in the **Lower Display Line 27**. Press the **Tone Mode Button 5** again until either **TREBLE MODE** or **BASS MODE**

# OPERATION

appears in the **Lower Display Line 5**, and then use the **Buttons 15** to boost or cut the low or high frequencies by up to  $\pm 10$ dB, in 2dB steps, until the desired setting is achieved. You may also totally remove the tone controls from the circuit so that the output is "flat" at any time by pressing the **Tone Mode Button 5** and then pressing the **Button 10** so that **TONE OUT** appears in the on-screen display and the **Lower Display Line 27**.

- For private listening, plug the 1/4" stereo phone plug from a pair of stereo headphones into the front-panel **Headphone Jack 4**. When the headphone's plug is connected, the phrase **HEADPHONES IN** will scroll once across the **Lower Display Line 27** and all speakers will be silenced. When the headphone plug is removed, the audio feed to the speakers will be restored.

## Surround Mode Selection

One of the important features of the AVR 140 is its ability to reproduce a full multichannel surround sound field from digital sources, analog matrix surround-encoded programs and standard stereo programs.

Selection of a surround mode is based on personal taste, as well as the type of program source material being used. For example, motion pictures or TV programs bearing the logo of one of the major surround-encoding processes, such as Dolby Surround or DTS Stereo, may be played in either the Dolby Digital, Dolby Pro Logic II or IIx Movie, DTS Neo:6 Cinema, or Logic 7 5.1 or 7.1 Cinema surround modes.

**NOTE:** Once a program has been encoded with matrix surround information, it retains the surround information as long as the program is broadcast in stereo. Thus, movies with surround sound may be decoded via any of the analog surround modes such as Dolby Pro Logic IIx Cinema, Logic 7 Cinema or DTS Neo:6 Cinema, when they are broadcast via conventional TV stations, cable, pay-TV and satellite transmission. In addition, a growing number of made-for-television programs, sports broadcasts, radio dramas and music CDs are also recorded in surround sound.

Even when a program is not listed as carrying intentional surround information, you may find that the Dolby Pro Logic IIx, Logic 7 Enhanced or DTS Neo:6, VMAx and the Hall or Theater modes often deliver enveloping surround presentations through the use of the natural information present in all stereo recordings.

Surround modes may be changed at any time by using either the front panel or remote control. Any changes made to the surround mode for that source will be retained in the AVR's menu, even after another

source is selected, or if the AVR is placed in Standby mode. To select a new surround mode from the front panel, first press the **Surround Mode Group Selector Button 7** until the desired major surround mode group, such as Dolby, DTS or Logic 7, is selected. Next, press the **Surround Mode Selector Button 8** to choose the specific individual surround mode.

To select a surround mode using the remote, press the button for the major surround mode group that includes the mode you wish to choose from: **Dolby 23**, **DTS Surround 24**, **DTS Neo:6 29**, **Logic 7 25**, **Stereo 28** or **DSP Surround 11**. The first press of the button will show the current mode from that group. To cycle through the available modes in that group, press the button again until the desired mode appears in the **Lower Display Line 27**, the on-screen display and in the **Surround Mode Indicators 28**.

The Dolby Digital, Dolby Digital EX and DTS 5.1, DTS-ES Matrix and DTS-ES Discrete modes may only be selected when a digital input is in use and a digital signal in that format is present. In addition, when a digital source is present, the AVR 140 will automatically select and switch to the correct mode, regardless of the mode that has been previously selected. For more information on selecting digital sources, see the Digital Audio Playback section.

When the 6-channel/8-channel direct inputs are in use there is no surround processing, as these inputs take the analog output signals from an optional, external DVD-Audio or SACD player, or another source device and carry them straight through to the volume control without any further digital processing.

To listen to a program in traditional two-channel stereo, using the front left and front right speakers only (plus the subwoofer, if installed and configured), press the **Stereo Button 23** until **SURR OFF** appears in the **Lower Display Line 27**, or press the **Surround Mode Group Selector 7** until the Stereo modes appear in the on-screen display and **Lower Display Line 27**. Next, press the **Surround Mode Select Button 8** until **SURROUND OFF** appears in the on-screen display and **Lower Display Line 30**.

When an analog audio source is in use, you may activate an analog bypass Surround Off mode, if you have removed the tone controls from the processing circuitry by pressing the **Tone Mode Button 5** and using the **Buttons 10 15** until the **TONE OUT** message appears in the **Lower Display Line 27**.

Normally, the DSP icon will appear in the **Surround Mode Indicators 28**, and the message

**SURROUND OFF** will appear in the lower line of the semi-OSD display. When the DSP icon appears, the incoming signal is digitized and any bass management settings are applied. This mode is recommended when your front speakers are not capable of reproducing the lower frequencies and are thus used with a subwoofer.

When the DSP icon is not lit in Surround Off mode with an analog audio input in use, the AVR is in analog bypass mode. The signal is being routed directly to the volume control, without entering the digital domain and without any bass management settings being applied. This mode is desirable when your left and right speakers are capable of reproducing low frequencies, and when you wish to hear the analog source material in its pure form.

## Digital Audio Playback

Digital audio is a major advancement over older analog surround processing systems such as Dolby Pro Logic. It delivers five, six or seven discrete channels: left front, center, right front, left surround, right surround and optionally one or two surround back channels. Each channel reproduces full frequency range (20Hz to 20kHz) and offers dramatically improved dynamic range and significant improvements to signal-to-noise ratios. In addition, digital systems have the capability to deliver an additional channel that is specifically devoted to low-frequency information. This is the ".1" channel referred to when you see these systems described as "5.1," "6.1" or "7.1". The bass channel is separate from the other channels, but since it is intentionally bandwidth-limited, sound designers have given it that unique designation.

### Dolby Digital

Dolby Digital is a standard part of DVD, and is available on specially encoded LD discs and satellite broadcasts and it is a part of the high-definition television (HDTV) system.

An optional, external RF demodulator is required to use the AVR 140 to listen to the Dolby Digital soundtracks available on laser discs. Connect the RF output of the LD player to the demodulator and then connect the digital output of the demodulator to the **Optical or Coaxial Inputs 18 19 19 23** of the AVR 140. No demodulator is required for use with DVD players or DTS-encoded laser discs.

# OPERATION

## DTS

DTS is another digital audio system that is capable of delivering 5.1 or 6.1 discrete or matrix sound field reproduction. Although both DTS and Dolby Digital are digital, they use different methods of encoding the signals, and thus they require different decoding circuits to convert the digital signals back to analog.

DTS-encoded soundtracks are available on select DVD and LD discs, as well as on special audio-only DTS discs. You may use any LD or CD player equipped with a digital output to play DTS-encoded discs with the AVR 140. All that is required is to connect the player's output to either an **Optical** or **Coaxial Input** on the rear panel **19****23** or front panel **18****19**.

In order to listen to DVDs encoded with DTS soundtracks, the DVD player must be compatible with the DTS signal as indicated by a DTS logo on the player's front panel. Early DVD players may not be able to play DTS-encoded DVDs. This does not indicate a problem with the AVR 140, as some players cannot pass the DTS signal through to the digital outputs. If you are in doubt as to the capability of your DVD player to handle DTS discs, consult the player's owner's manual.

**IMPORTANT NOTE:** Many DVD players have a default setting that does not pass through the DTS data, even though the machine is capable of doing so. If your DVD player has the "DTS Digital Out" logo but does not trigger DTS playback in the AVR 140, change the player's settings in the "Audio" or "Bitstream" configuration menu so that DTS playback is enabled. The method for doing this will vary with each player. In some cases, the proper menu choice will be "Original," while in others it will be "DTS." Consult the owner's manual for your player to find the specific information to find the proper setting.

## Selecting a Digital Source

To utilize either digital mode, you must have properly connected a digital source to the AVR 140. Connect the digital outputs from DVD players, HDTV receivers, satellite systems or CD players to the **Optical** or **Coaxial Inputs** **18****19****19****23**. In order to provide a backup signal and a source for analog stereo recording, the analog outputs provided on digital source equipment should also be connected to their appropriate inputs on the AVR 140 rear panel (e.g., connect the analog stereo audio output from a DVD to the **DVD Audio Inputs** **23** on the rear panel when you connect the source's digital outputs).

If you have not already configured an input for a digital source using the on-screen menus as shown on page 17, first select the input using the remote or front-panel controls as outlined in this manual. Next, select the digital source by pressing the **Digital Select**

**Button** **17****13** and then using the **▲/▼ Buttons** **14** on the remote or the **◀▶ Selector Buttons** **10** on the front panel to choose any of the **OPTICAL** or **COAXIAL** inputs, as they appear in the **Upper Display Line** **26** or on-screen display. When the digital source is playing, the AVR 140 will automatically detect which type of digital data stream is being decoded and display that information in the **Upper Display Line** **26**.

## Digital Bitstream Indications

When a digital source is playing, the AVR 140 senses the type of bitstream data that is present. Using this information, the correct surround mode will automatically be selected. For example, DTS bitstreams will cause the unit to switch to DTS decoding, and Dolby Digital bitstreams will enable Dolby Digital decoding. When the unit senses PCM data from CDs or LDs, it will default to Logic 7 Music mode, although you may select any of the standard surround modes, such as Dolby Pro Logic II or Logic 7. Since the range of available surround modes is dependent on the type of digital data that is present, the AVR 140 uses a variety of indicators and messages to let you know what type of signal is present. These messages will appear shortly after an input or surround mode is changed, and they will remain in the **Lower Display Line** **27** for about five seconds before that portion of the display returns to the normal surround mode indication.

## Surround Mode Channel Indications

For Dolby Digital and DTS sources, a three digit indication will appear, showing the number of channels present in the data. An example of this type of display is 3/2/.1.

The first number indicates how many discrete front channel signals are present.

- A "3" tells you that separate front left, center and front right signals are available. This will be displayed for Dolby Digital 5.1 and DTS 5.1 programs.
- A "2" tells you that separate front left and right signals are available, but there is no discrete center channel signal. This will be displayed for Dolby Digital bitstreams that have stereo program material.
- A "1" tells you that there is only a mono channel available in the Dolby Digital bitstream.

The middle number indicates how many discrete surround channel signals are present.

- A "2" tells you that separate surround left and right signals are available. This will be displayed for Dolby Digital 5.1 and DTS 5.1 programs.
- A "1" tells you that there is only a single, surround-encoded surround channel. This will appear for

Dolby Digital bitstreams that have matrix encoding.

- A "0" indicates that there is no surround channel information. This will be displayed for two-channel stereo programs.

The last number indicates whether there is a discrete low-frequency effects (LFE) channel. This is the ".1" in the common abbreviation of "5.1" sound and is a special channel that contains only bass frequencies.

- A "1" tells you that an LFE channel is present. This will be displayed for Dolby Digital 5.1 and DTS 5.1 programs, as available.
- A "0" indicates that there is no LFE channel information available. However, even when there is no dedicated LFE channel, low-frequency sound will be present at the subwoofer output when the speaker configuration is set to show the presence of a subwoofer.

The information in the right side of the display will tell you if the digital audio data contains a special flag signal that will automatically activate the appropriate 6.1 or 7.1 mode. This will be shown as **EX-ON** or **EX-OFF** for Dolby Digital bitstreams and **ES-ON** or **ES-OFF** for DTS bitstreams.

If the EX flag is off, and your receiver has been configured for 6.1/7.1 operation, you may manually turn on EX processing as appropriate by simply selecting the Dolby Digital EX surround mode as described on pages 18 and 26. When the ES flag is not present in a DTS bitstream, you may benefit from a 6.1-channel presentation by selecting the DTS+Neo:6 surround mode as described on pages 18 and 26. In that mode, the DTS Neo:6 algorithms will be used to derive the surround back channel from the DTS bitstream information.

When Dolby Digital 3/2/.1 or DTS 3/2/.1 signals are being played, the AVR will automatically switch to the proper surround mode, and no other processing may be selected, with these exceptions:

- When a Dolby Digital 2.0 signal is detected, you may choose to listen to it in its native form. To do so, scroll through the Dolby surround modes until the Stereo icon lights in the **Surround Mode Indicators** **23** in addition to the Dolby Digital icon. Alternatively, you may engage surround processing by scrolling through the Dolby Pro Logic II and Ix modes, and the Dolby Pro Logic icon will light in addition to the Dolby Digital icon.
- As indicated above, when the EX flag is not present in a Dolby Digital bitstream, you may scroll through the Dolby surround modes to manually select Dolby Digital EX processing.

## OPERATION

- When a DTS 5.1 signal is detected, you may listen to it as a two-channel presentation, a 5.1-channel presentation or a 6.1-channel presentation (if your AVR is configured for 6.1 operation). To hear a two-channel presentation, scroll through the DTS surround modes until the Stereo icon lights in the **Surround Mode Indicators 23** in addition to the DTS icon. Continue scrolling to engage DTS 5.1 processing or DTS+Neo:6 (6-channel) processing.
- If a DTS-ES 6.1 Discrete signal is present, you may choose a two-channel presentation, a 5.1-channel presentation or a 6.1-channel presentation (if your AVR has been configured for 6.1 operation). Scroll through the DTS surround modes until the Stereo icon lights in the **Surround Mode Indicators 28** in addition to the DTS icon. Continue scrolling to engage DTS 5.1 processing or DTS-ES Discrete processing.

When a Dolby Digital signal with a 3/1/0 or 2/0/0 signal is detected you may select any of the Dolby surround modes.

See page 33 for information on setting a default surround mode.

It is always a good idea to check the readout for the channel data to make certain that it matches the audio logo information shown on the back of a DVD package. In some cases you will see indication for "2/0/0" even when the disc contains a full 5.1, or 3/2/1 signal. When this happens, check the audio output settings for your DVD player or the audio menu selections for the specific disc being played to make certain that the player is sending the correct signal to the AVR.

### PCM Audio Playback

PCM is the abbreviation for Pulse Code Modulation, which is the type of digital signal used for standard CD playback and other non-Dolby Digital and non-DTS digital sources such as Mini-Disc. The digital circuits in the AVR 140 are capable of high-quality digital-to-analog decoding, and they may be connected directly to the digital audio output of your CD or LD player.

Connections may be made to either the rear-panel **Optical or Coaxial Inputs 19/23** or the front-panel **Digital Inputs 18/19**.

To listen to a PCM digital source, first select the input for the desired source (e.g., CD). Next press the **Digital Select Button 13/17** and then use the **▲/▼ Buttons 14** on the remote, or the **◀▶ Selector Buttons 10** on the front panel, until the desired choice appears in the **Upper Display Line 26**.

During PCM playback, you may select any Surround mode except Dolby Digital or DTS.

When a PCM signal is detected, the **Lower Display**

**Line 27** will briefly show a message with the letters PCM, in addition to a readout of the sampling frequency of the digital signal. In most cases this will be **48kHz**, though in the case of specially mastered, high-resolution audio discs you will see a **96kHz** indication.

Some DVD discs are recorded with both "5.1" and "2.0" versions of the same sound-track. When playing a DVD, always be certain to check the type of material on the disc. Most discs show this information in the form of a listing or icon on the back of the disc jacket. When a disc does offer multiple soundtrack choices you may have to make some adjustments to your DVD player (usually with the "Audio Select" button or in a menu screen on the disc) to send a full 5.1 feed to the AVR 140. It is also possible for the type of signal feed to change during the course of a DVD playback. In some cases the menu screens and previews of special material will only be recorded in 2.0 audio, while the main feature is available in 5.1 audio. As long as your DVD player is set for 6-channel output, the AVR 140 will automatically sense changes to the bitstream and channel count and reflect them in these indicators.

### Speaker/Channel Indicators

In addition to the bitstream indicators, the AVR 140 features a set of unique channel-input indicators that tell you how many channels of digital information are being received and/or whether the digital signal is interrupted. (See Figure 9.)

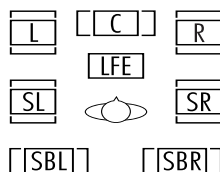

Figure 9

These indicators are the L/C/R/LFE/SL/SR/SBL/SBR letters that are inside the center boxes of the **Speaker/Channel Input Indicators 25** on the front panel. Remember that the AVR 140 is capable of processing a 7.1-channel signal, although you may only connect one surround back speaker to it. It will automatically combine the left and right surround back channel information, and output it through the single surround back speaker, if you have configured that speaker using the **SPEAKER SIZE** menu (Figure 8).

When a standard analog signal is in use, only the "L" and "R" indicators will light, as analog signals have only left and right channels.

Digital signals, however, may have two, five, six or seven channels, depending on the program material, the method of transmission and the way in which it was encoded. When a digital signal is playing, the let-

ters in these indicators will light in response to the specific signal being received. It is important to note that although Dolby Digital, for example, is referred to as a "5.1" system, not all Dolby Digital DVDs or programs are encoded for 5.1. Thus, it is sometimes normal for a DVD with a Dolby Digital soundtrack to trigger only the "L" and "R" indicators.

**NOTE:** Many DVD discs are recorded with both "5.1" and "2.0" versions of the same soundtrack. When playing a DVD, always be certain to check the type of material on the disc. Most discs show this information in the form of a listing or icon on the back of the disc jacket. When a disc does offer multiple soundtrack choices, you may have to make some adjustments to your DVD player (usually with the "Audio Select" button or in a menu screen on the disc) to send a full 5.1 feed to the AVR 140. It is also possible for the type of signal feed to change during the course of a DVD playback. In some cases, the menu screens and previews of special material will only be recorded in 2.0 audio, while the main feature is available in 5.1 audio. The AVR 140 will automatically sense changes to the bitstream and channel count and reflect them in these indicators.

The letters used by the **Speaker/Channel Input Indicators 25** also flash to indicate when a bitstream has been interrupted. This will happen when a digital input source is selected before the playback starts, or when a digital source such as a DVD is paused. The flashing indicators remind you that the playback has stopped due to the absence of a digital signal and not through any fault of the AVR 140. This is normal, and the digital playback will resume once the playback is started again.

### Night Mode

A special feature of Dolby Digital is the Night mode, which enables specially encoded Dolby Digital input sources to be played back with full digital intelligibility while reducing the minimum peak level by 1/4 to 1/3. This prevents abruptly loud transitions from disturbing others, without reducing the impact of the digital source. The Night mode is available only when Dolby Digital signals with special data are being played.

The Night mode may be engaged when a Dolby Digital DVD is playing by pressing the **Night Mode Button 12** on the remote. Next, press the **▲/▼ Buttons 14** to select either the middle range or full compression versions of the Night mode. To turn the Night mode off, press the **▲/▼ Buttons 14** until the message in the lower third of the video display and in the **Lower Display Line 27** reads **D-RANGE OFF**.



# OPERATION

The Night mode may also be selected to always be on at either level of compression using the options in the **DOLBY** menu. See page 19 for information on using the menus to set this option.

## IMPORTANT NOTES ON DIGITAL PLAYBACK:

- When the digital playback source is stopped, or in a pause, fast-forward or chapter-search mode, the digital audio data will momentarily stop, the channel position letters inside the **Speaker/Channel Input Indicators 25** will flash. This is normal and does not indicate a problem with either the AVR 140 or the source machine. The AVR 140 will return to digital playback as soon as the data is available and when the machine is in a standard play mode.
- Although the AVR 140 will decode virtually all current DVD movies, CDs and HDTV sources, it is possible that some future digital sources may not be compatible with the AVR 140.
- Not all digitally encoded programs contain full 5.1- or 6.1-channel audio. Consult the program guide that accompanies the DVD or laser disc to determine which type of audio has been recorded on the disc. The AVR 140 will automatically sense the type of digital surround encoding used and adjust to accommodate it.
- When some digital sources are playing, you may not be able to select some of the analog surround modes such as Dolby Pro Logic II or Ix, Dolby 3 Stereo, Hall, Theater or Logic 7.
- When a Dolby Digital or DTS source is playing, it is not possible to make an analog recording using the **Tape Outputs 3** and **Video 1 Audio Outputs 30**. However, the digital signals will be passed through to the **Digital Audio Outputs 16/17**.

## Tuner Operation

The AVR 140's tuner is capable of tuning AM, FM and FM Stereo broadcast stations. Stations may be tuned manually, or they may be stored as favorite station presets and recalled from a 30-position memory.

### Station Selection

1. Press the **AM/FM Tuner Select Button 7** on the remote to select the tuner as an input. The tuner may be selected from the front panel either by pressing the **Input Source Selector 16** until the tuner is active or by pressing the **Tuner Band Selector 11**.
2. Press the **AM/FM Tuner Select Button 7** or **Tuner Band Selector 11** again to switch between AM and FM so that the desired frequency band is selected.
3. Press the **Tuner Mode Button 17/19** to select manual or automatic tuning.

When the button is pressed so that **AUTO** appears in the **Lower Display Line 27** each press of the **Tuning Selectors 9/21** will put the tuner in a scan mode that seeks the next higher or lower frequency station with acceptable signal strength. An **AUTO ST TUNED** indication will momentarily appear when the station stops at a stereo FM station, and an **AUTO TUNED** indication will momentarily appear when an AM or monaural FM station is tuned. Press the Tuning buttons again to scan to the next receivable station.

When the button is pressed so that **MANUAL** appears in the **Lower Display Line 27** each tap of the Selector will increase or decrease the frequency by one increment. When the tuner receives a strong-enough signal for adequate reception, **MANUAL TUNED** will appear in the **Lower Display Line 27**.

4. Stations may also be tuned directly in either the automatic or manual mode. To enter a station's frequency directly, first select the AM or FM band as desired by pressing the **AM/FM Tuner Select Button 7**. Next, press the **Direct Button 20**. Within five seconds of seeing the **DIRECT IN** scroll in the **Upper Display Line 26**, enter the station frequency by pressing the **Numeric Keys 18**. If you press an incorrect button while entering a direct frequency, press the **Clear Button 33** to start over.

**NOTE:** When FM reception of a station is weak, audio quality will be increased by switching to Mono mode by pressing the **Tuner Mode Button 17/19** so that **MANUAL** appears momentarily in the **Lower Display Line 27** and goes out. This will also activate manual tuning mode.

### Preset Tuning

Using the remote, up to 30 stations may be stored in the AVR 140's memory for easy recall using the front panel controls or the remote.

To enter a station into the memory, first tune the station using the steps outlined above. Then:

1. Press the **Memory Button 34** on the remote. Two underscore lines will appear at the far right side of the **Upper Display Line 26**.
2. Within five seconds, press the **Numeric Keys 18** corresponding to the location where you wish to store this station's frequency. Once entered, the preset number will appear in the **Upper Display Line 26**.
3. Repeat the process after tuning any additional stations to be preset.

### Recalling Preset Stations

- To manually select a station previously entered in the preset memory, press the **Numeric Keys 18** that correspond to the desired station's memory location.
- To manually tune through the list of stored preset stations one by one, press the **Preset Stations Selector Buttons 14/30** on the front panel or remote.

### Recording

In normal operation, the audio or video source selected for listening through the AVR 140 is sent to the record outputs. This means that any program you are watching or listening to may be recorded simply by placing machines connected to the **Tape Outputs 3** or **Video 1 Audio/Video and S-Video Outputs 24/30** in the Record mode.

When a digital audio recorder is connected to the **Digital Audio Outputs 16/17**, you are able to record the digital signal using a CD-R, MiniDisc or other digital recording system.

### NOTES:

- The digital outputs are active only when a digital signal is present, and they do not convert an analog input to a digital signal, or change the format of the digital signal. In addition, the digital recorder must be compatible with the output signal. For example, the PCM digital input from a CD player may be recorded on a CD-R or MiniDisc, but Dolby Digital or DTS signals may not.
- Please make certain that you are aware of any copyright restrictions on any material you copy. Unauthorized duplication of copyrighted materials is prohibited by federal law.

### Using The Bridge™

When Harman Kardon's **The Bridge™** (optional) is connected and a compatible Apple® iPod® is docked in The Bridge, press the **The Bridge™ DMP Selector Button 40** to choose the iPod as the input source. Pressing the **The Bridge™ DMP Selector Button 40** will also activate the AVR remote's control codes for the iPod, and you may also use the front-panel controls to operate the iPod. You may also select **The Bridge™ DMP** as the source from the front panel by repeatedly pressing the **Input Source Selector 16** until **DMP** appears in the **Upper Display Line 26**, although no **Input Indicator 24** will light.

When The Bridge is properly connected and a compatible iPod is properly docked, the **Upper Display Line 26** will read **DMP / CONNECTED**. Once that message appears, use the remote or front-panel buttons to control the iPod. See the Function List

## OPERATION

Table on pages 37–38 for a listing of the remote control buttons that have been programmed to control the iPod. In brief, the **Reverse Search, Play and Forward Search Buttons 27** and the **▲/▼/◀▶ Buttons 14 15** and **Set Button 16** may be used in a similar manner to the corresponding controls on the iPod. Additional buttons on the remote may also be used to navigate your iPod's albums and playlists. Complete details on operating an iPod using **Bridge** and an AVR remote are furnished with **Bridge**.

The front-panel controls may be used to access a limited number of iPod functions. Press the **Tuner Mode Button 17** to play or pause the current track. The **Tuning Selector 9** may be used to search reverse (left side of button) or forward (right side of button) through the tracks. Press the **Tuner Band Selector 11** to call up the iPod's menu. Press the **◀▶ Buttons 10** to scroll, and the **Set Button 12** to select.

### Output Level Trim Adjustment

Normal output level adjustment for the AVR 140 is established using the test tone, as outlined on pages 23–24. In some cases, however, it may be desirable to adjust the output levels using program material such as a test disc, or a selection you are familiar with. Additionally, the output level for the subwoofer can only be adjusted using this procedure.

To adjust the output levels using program material, first set the reference volume for the front left and front right channels using the **Volume Control 23 38**.

If you are using a disc with test signals or an external signal generator as the source from which to trim the output levels, you may use a handheld SPL meter to guide you to the correct SPL levels. Set the meter to the C-Weighting Slow scale, and adjust the volume until the meter reads 75dB.

Once the reference level has been set, press the **Channel Select Button 13** and **FRONT LEVEL** will appear in the **Lower Display Line 27** and semi-OSD. To change the level, first press the **Set Button 16**, and then use the **▲/▼ Buttons 14** to raise or lower the level. DO NOT use the volume control, as this will alter the reference setting.

Once the change has been made, press the **Set Button 16** and then press the **▲/▼ Buttons 14** to select the next output channel location you wish to adjust. To adjust the subwoofer level, press the **▲/▼ Buttons 14** until **W00FER LEVEL** appears in the **Lower Display Line 27** and on screen.

Repeat the procedure as needed until all channels requiring adjustment have been set. When all adjust-

ments have been made and no further adjustments are made for five seconds, the AVR 140 will return to normal operation.

The channel output for any input may also be adjusted using the full-OSD on-screen menu system. First, set the volume to a comfortable listening level using the **Volume Control 23 38**. Then, press the **OSD Button 22** to bring up the **MASTER MENU** (Figure 1). Press the **▼ Button 14** until the on-screen ► cursor is next to the **MANUAL SETUP** line. Press the **Set Button 16** to display the **MANUAL SETUP** submenu, and use the **▲/▼ Buttons 14** to scroll to the **CHANNEL ADJUST** line. Press the **Set Button 16** again to display the **CHANNEL ADJUST** submenu.

Once the menu appears on your video screen, first use the **▲/▼ Buttons 14** to move the on-screen ► cursor so that it is next to the **TEST TONE** line. Press the **◀▶ Buttons 15** so that **OFF** appears. This will turn off the test tone and allow you to use your external test disc or other source material as the reference. Then, use the **▲/▼ Buttons 14** until the ► cursor is next to the **TEST TONE SEQ** line so that you may select between automatic and manual movement of the test tone from one channel to the next. When **AUTO** appears, the test tone will automatically circulate from one channel to the next, pausing momentarily at each channel. If you adjust the level of any channel, the test tone will remain paused at that channel until several seconds after your last adjustment before continuing to the next channel. When **MANUAL** appears, the test tone will remain paused at the last channel until you use the **▲/▼ Buttons 14** to select another channel.

At each channel position, use the **◀▶ Buttons 15** to change the output level. Remember, the goal is to have the output level at each channel be equal when heard at the listening position. Regardless of the method used to adjust the output levels, whether the test tone or an external source is used, remember that when the AVR is configured for 6.1 operation with only a single surround back speaker, you will still have an output adjustment for both a surround back left and surround back right speaker location even though there is only one speaker. This is not a duplicate adjustment. Rather, it is needed so that the proper balance is achieved for 7.1-channel processing modes when the discrete surround back channels are mixed to a single output.

If you wish to reset all the levels to their original factory default of 0dB offset, press the **▲/▼ Buttons 14** so that the on-screen cursor is next to the **CHANNEL RESET** line and press the **◀▶ Buttons 15** so that the word **ON** appears. After the levels are reset, resume the procedure outlined above

to reset the levels to the desired settings. When all adjustments are done, press the **▲/▼ Buttons 14** to move the on-screen ► cursor so that it is next to **BACK TO MANUAL SETUP** and then press the **Set Button 16** if you wish to go back to the manual setup menu to make other adjustments. If you have no other adjustments to make, press the **OSD Button 22** to exit the menu system.

**NOTE:** The output levels may be separately trimmed for each digital and analog surround mode. If you wish to have different trim levels for a specific mode, select that mode and then follow the instructions in the steps shown earlier.

### Memory Backup

This product is equipped with a memory backup system that preserves the system configuration information and tuner presets if the unit is accidentally unplugged or subjected to a power outage. This memory will last for approximately four weeks, after which time all information must be reentered.



## TROUBLESHOOTING GUIDE

SYMPTOM	CAUSE	SOLUTION
Unit does not function when Main Power Switch is pushed	<ul style="list-style-type: none"> <li>No AC Power</li> </ul>	<ul style="list-style-type: none"> <li>Make certain AC power cord is plugged into a live outlet</li> <li>Check to see whether outlet is switch-controlled</li> </ul>
Display lights, but no sound or picture	<ul style="list-style-type: none"> <li>Intermittent input connections</li> <li><b>Mute</b> is on</li> <li>Volume control is down</li> </ul>	<ul style="list-style-type: none"> <li>Make certain that all input and speaker connections are secure</li> <li>Press <b>Mute Button 42</b></li> <li>Turn up volume control</li> </ul>
No sound from any speaker; light around power switch is red	<ul style="list-style-type: none"> <li>Amplifier is in protection mode due to possible short</li> <li>Amplifier is in protection mode due to internal problems</li> </ul>	<ul style="list-style-type: none"> <li>Check speaker wire connections for shorts at receiver and speaker ends</li> <li>Contact your local Harman Kardon service center</li> </ul>
No sound from surround or center speakers	<ul style="list-style-type: none"> <li>Incorrect surround mode</li> <li>Input is monaural</li> <li>Incorrect configuration</li> <li>Stereo or Mono program material</li> </ul>	<ul style="list-style-type: none"> <li>Select a mode other than Stereo</li> <li>There is no surround information from mono sources</li> <li>Check speaker mode configuration</li> <li>The surround decoder may not create center- or rear-channel information from nonencoded programs</li> </ul>
Unit does not respond to remote commands	<ul style="list-style-type: none"> <li>Weak batteries in remote</li> <li>Wrong device selected</li> <li>Remote sensor is obscured</li> </ul>	<ul style="list-style-type: none"> <li>Change remote batteries</li> <li>Press the AVR selector</li> <li>Make certain front panel sensor is visible to remote or connect remote sensor</li> </ul>
Intermittent buzzing in tuner	<ul style="list-style-type: none"> <li>Local interference</li> </ul>	<ul style="list-style-type: none"> <li>Move unit or antenna away from computers, fluorescent lights, motors or other electrical appliances</li> </ul>
Letters flash in the channel indicator display and digital audio stops	<ul style="list-style-type: none"> <li>Digital audio feed paused</li> </ul>	<ul style="list-style-type: none"> <li>Resume play for DVD</li> <li>Check that Digital Input is selected</li> </ul>

In addition to the items shown above, additional information on troubleshooting possible problems with your AVR 140, or installation-related issues, may be found in the list of "Frequently Asked Questions" which is located in the Product Support section of our Web site at [www.harmankardon.com](http://www.harmankardon.com).

## Processor Reset

In the rare case where the unit's operation or the displays seem abnormal, the cause may involve the erratic operation of the system's memory or microprocessor.

To correct this problem, first unplug the unit from the AC wall outlet and wait at least three minutes. After the pause, reconnect the AC power cord and check the unit's operation. If the system still malfunctions, a system reset may clear the problem.

To clear the AVR 140's entire system memory including tuner presets, output level settings, delay times and speaker configuration data, first place the AVR in Standby Mode, and then press and hold the **Tone Mode Button 5** button for three seconds. The unit will turn on automatically.

**NOTE:** Resetting the processor will erase any configuration settings you have made for speakers, output levels, surround modes, digital input assignments as well as the tuner presets. The unit will be returned to the factory presets, and all settings for these items must be reentered.

If the system is still operating incorrectly, there may have been an electronic discharge or severe AC line interference that has corrupted the memory or microprocessor.

If these steps do not solve the problem, consult an authorized Harman Kardon service center.

1. Removing the Top Cabinet  
Remove the Screws

① - ⑬

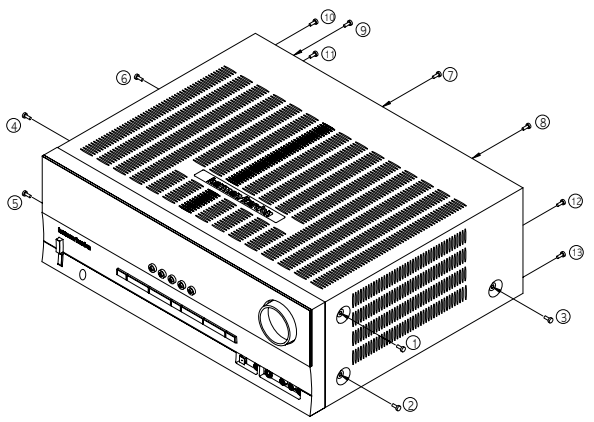

2. Removing the Front Panel  
Remove the Screws

① - ⑨

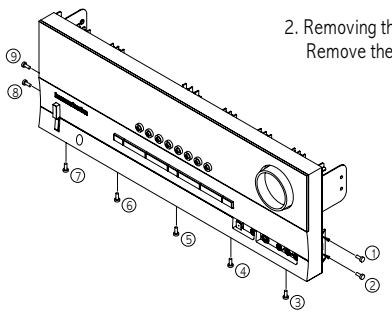

3. Removing the Rear Panel  
Remove the Screws

① - ⑳

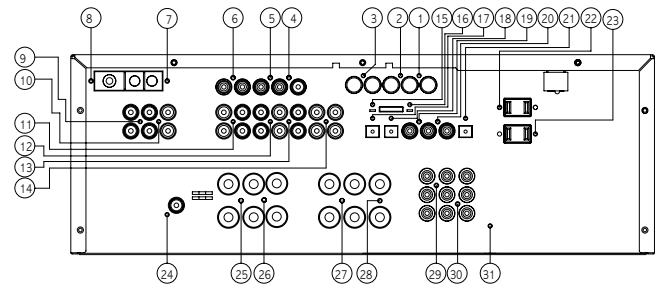

4. Removing the Main PCB  
Remove the Screws

① - ⑥

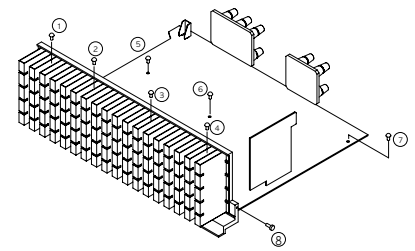

# AVR140 EXPLODED VIEW

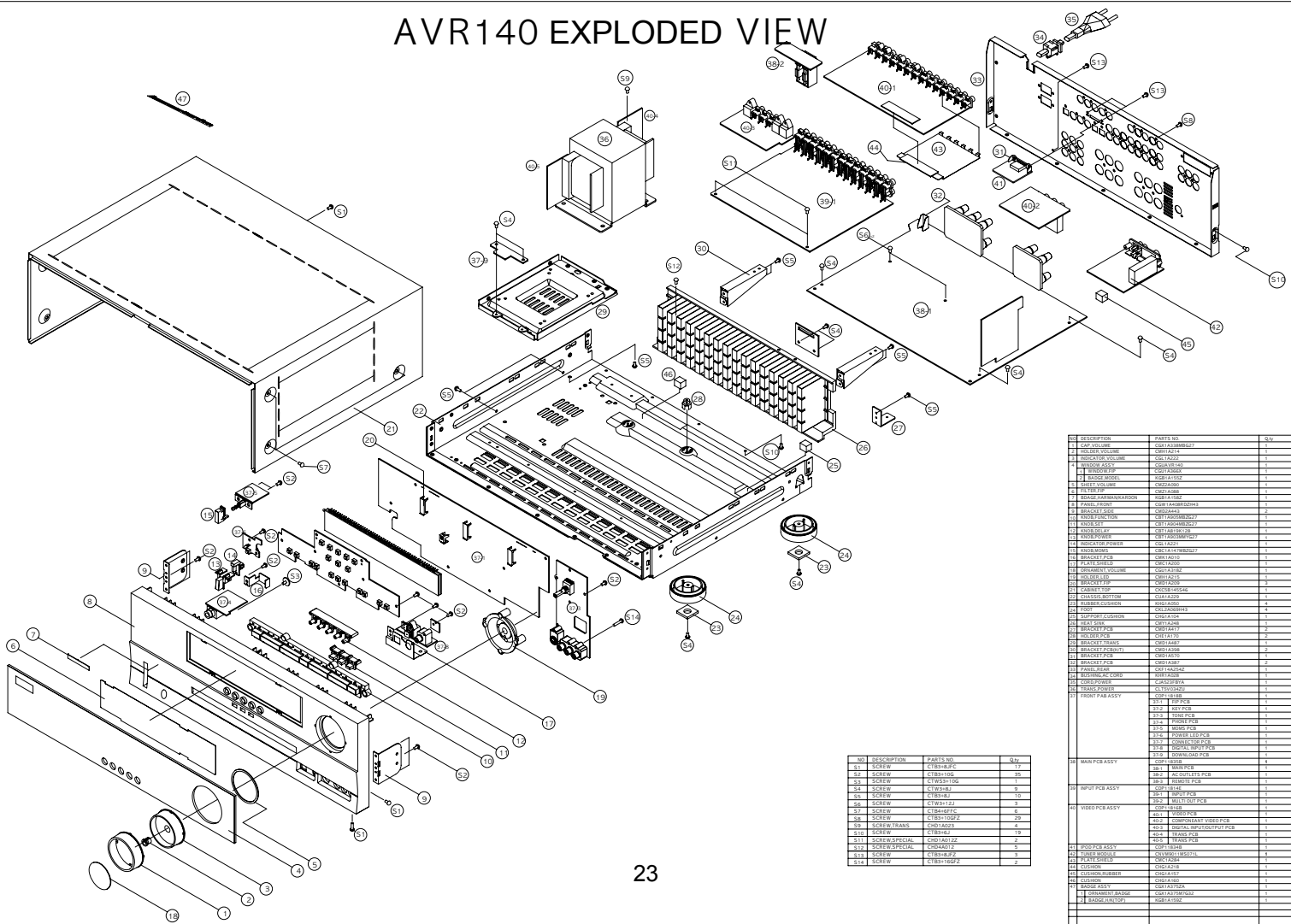

NO.	DESCRIPTION	PARTS NO.	QTY.
S1	SCREW	CTB8H3PC	17
S2	SCREW	CTB8H10C	35
S3	SCREW	CTW53110G	1
S4	SCREW	CTB8H8L	10
S5	SCREW	CTB8H8L	10
S6	SCREW	CTW8H12J	0
S7	SCREW	CTB8H4PC	6
S8	SCREW	CTB8H10GF	29
S9	SCREW	CTB8H8G	2
S10	SCREW	CTB8H8J	19
S11	SCREW/SPECIAL	CTW40H2Z	2
S12	SCREW/SPECIAL	CTW40H2F	2
S13	SCREW	CTB8H4PC	5
S14	SCREW	CTB8H10GF	2

NO.	DESCRIPTION	PARTS NO.	QTY.
1	TOP VOLUME	CRH1A214	1
2	ROTARY VOLUME	CRH1A212	1
3	ROTARY VOLUME	CRH1A210	1
4	ROTARY ASSY	CRH1A210	1
5	BRIDGE ASSY	CRB1A1102	1
6	TRIPLE LOG	CRB1A100	1
7	SIGNAL PERMANENT/ARCON	CRB1A100	1
8	BRACKET SIDE	CRB1A100	2
9	VIDEO FILTER	CRB1A100M202	1
10	VIDEO POWER	CRB1A100M202	1
11	VIDEO POWER	CRB1A100M202	1
12	VIDEO POWER	CRB1A100M202	1
13	VIDEO POWER	CRB1A100M202	1
14	VIDEO POWER	CRB1A100M202	1
15	VIDEO POWER	CRB1A100M202	1
16	VIDEO POWER	CRB1A100M202	1
17	VIDEO POWER	CRB1A100M202	1
18	VIDEO POWER	CRB1A100M202	1
19	VIDEO POWER	CRB1A100M202	1
20	VIDEO POWER	CRB1A100M202	1
21	VIDEO POWER	CRB1A100M202	1
22	VIDEO POWER	CRB1A100M202	1
23	VIDEO POWER	CRB1A100M202	1
24	VIDEO POWER	CRB1A100M202	1
25	VIDEO POWER	CRB1A100M202	1
26	VIDEO POWER	CRB1A100M202	1
27	VIDEO POWER	CRB1A100M202	1
28	VIDEO POWER	CRB1A100M202	1
29	VIDEO POWER	CRB1A100M202	1
30	VIDEO POWER	CRB1A100M202	1
31	VIDEO POWER	CRB1A100M202	1
32	VIDEO POWER	CRB1A100M202	1
33	VIDEO POWER	CRB1A100M202	1
34	VIDEO POWER	CRB1A100M202	1
35	VIDEO POWER	CRB1A100M202	1
36	VIDEO POWER	CRB1A100M202	1
37	VIDEO POWER	CRB1A100M202	1
38	VIDEO POWER	CRB1A100M202	1
39	VIDEO POWER	CRB1A100M202	1
40	VIDEO POWER	CRB1A100M202	1
41	VIDEO POWER	CRB1A100M202	1
42	VIDEO POWER	CRB1A100M202	1
43	VIDEO POWER	CRB1A100M202	1
44	VIDEO POWER	CRB1A100M202	1
45	VIDEO POWER	CRB1A100M202	1
46	VIDEO POWER	CRB1A100M202	1
47	VIDEO POWER	CRB1A100M202	1
48	VIDEO POWER	CRB1A100M202	1
49	VIDEO POWER	CRB1A100M202	1
50	VIDEO POWER	CRB1A100M202	1
51	VIDEO POWER	CRB1A100M202	1

NO	DESCRIPTION	PARTS NO.	Q,ty
1	CAP,VOLUME	CGX1A338MBG27	1
2	HOLDER,VOLUME	CMH1A214	1
3	INDICATOR,VOLUME	CGL1A222	1
4	WINDOW ASS'Y	CGUAVR140	1
	1 WINDOW,FIP	CGU1A366X	1
	2 BADGE,MODEL	KGB1A155Z	1
5	SHEET,VOLUME	CMZ2A090	1
6	FILTER,FIP	CMZ1A088	1
7	BDAGE,HARMAN/KARDON	KGB1A158Z	1
8	PANEL,FRONT	CGW1A408RDZH43	1
9	BRACKET,SIDE	CMD2A443	2
10	KNOB,FUNCTION	CBT1A905MBZG27	1
11	KNOB,SET	CBT1A904MBZG27	1
12	KNOB,DELAY	CBT1A819K128	1
13	KNOB,POWER	CBT1A903MMYG27	1
14	INDICATOR,POWER	CGL1A221	1
15	KNOB,MOMS	CBC1A147MBZG27	1
16	BRACKET,PCB	CMK1A010	1
17	PLATE,SHIELD	CMC1A200	1
18	ORNAMENT,VOLUME	CGU1A318Z	1
19	HOLDER,LED	CMH1A215	1
20	BRACKET,FIP	CMD1A209	3
21	CABINET, TOP	CKC5B145S46	1
22	CHASSIS,BOTTOM	CUA1A229	1
23	RUBBER,CUSHION	KHG1A050	4
24	FOOT	CKL2A069H43	4
25	SUPPORT,CUSHION	CHG1A104	1
26	HEAT SINK	CMY1A248	1
27	BRACKET,PCB	CMD1A417	2
28	HOLDER,PCB	CHE1A170	2
29	BRACKET,TRANS	CMD1A487	1
30	BRACKET,PCB(H/T)	CMD1A398	2
31	BRACKET,PCB	CMD1A570	1
32	BRACKET,PCB	CMD1A387	2
33	PANEL,REAR	CKF14A254Z	1
34	BUSHING,AC CORD	KHR1A028	1
35	CORD,POWER	CJA523FBYA	1
36	TRANS,POWER	CLT5V034ZU	1
37	FRONT PCB ASS'Y	COP11818B	1
	37-1 FIP PCB		1
	37-2 KEY PCB		1
	37-3 TONE PCB		1
	37-4 PHONE PCB		1
	37-5 MOMS PCB		1
	37-6 POWER LED PCB		1
	37-7 CONNECTOR PCB		1
	37-8 DIGITAL INPUT PCB		1
	37-9 DOWNLOAD PCB		1
38	MAIN PCB ASS'Y	COP11835B	1
	38-1 MAIN PCB		1
	38-2 AC OUTLETS PCB		1
	38-3 REMOTE PCB		1
39	INPUT PCB ASS'Y	COP11814E	1
	39-1 INPUT PCB		1
	39-2 MULTI OUT PCB		1
40	VIDEO PCB ASS'Y	COP11816B	1
	40-1 VIDEO PCB		1
	40-2 COMPONENT VIDEO PCB		1
	40-3 DIGITAL INPUT/OUTPUT PCB		1
	40-4 TRANS PCB		1
	40-5 TRANS PCB		1
41	IPOD PCB ASS'Y	COP11834B	1
42	TUNER MODULE	CNVM9011MS071L	1
43	PLATE,SHIELD	CMC1A284	1
44	CUSHION	CHG1A218	1
45	CUSHION,RUBBER	CHG1A157	1
46	CUSHION	CHG1A160	1
47	BADGE ASS'Y	CGX1A375ZA	1
	1 ORNAMENT,BADGE	CGX1A375M7G32	1
	2 BADGE,H/K(TOP)	KGB1A159Z	1

### AMPLIFIER SECTION BIAS ADJUSTMENT

**Measurement condition**

. No input signal or volume position is minimum.

**Standard value.**

. Ideal current = 48mA ( ± 5%)

. Ideal DC Voltage = 25.92mV ( ± 5%)

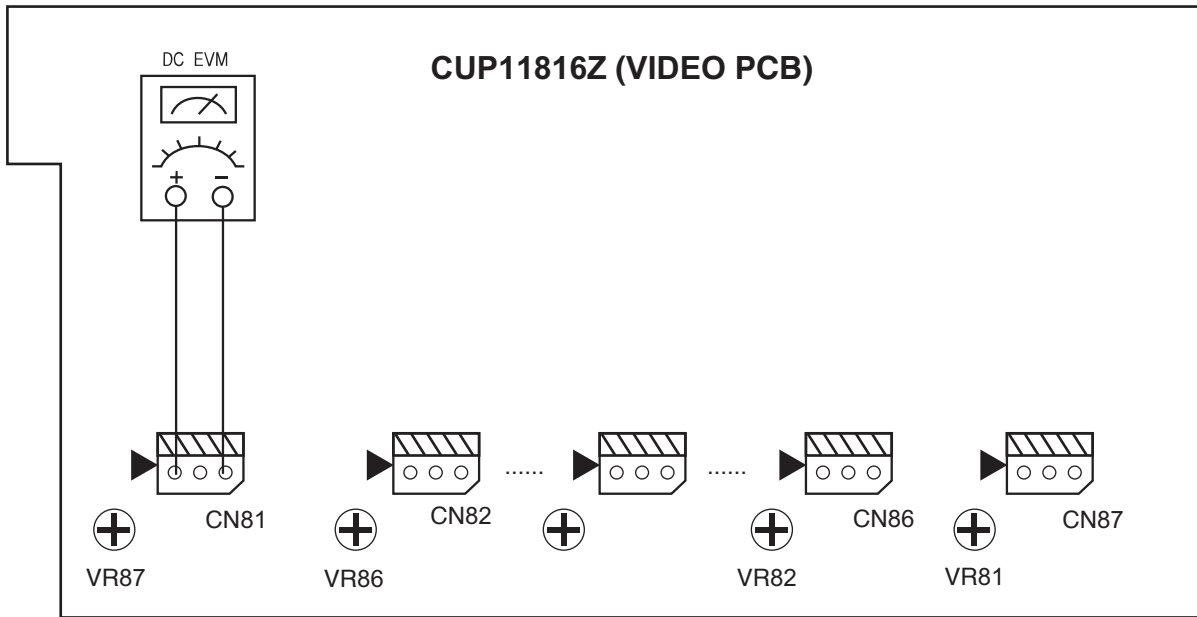

DC VOLTMETER.....Connect to CN81,CN82,CN83,CN84,CN85,CN86,CN87

NO.	Channel	Adjust for	Adjustment
1	Front Left	25.92mV (±5%)	VR83
2	Front Right	25.92mV (±5%)	VR84
3	Center	25.92mV (±5%)	VR85
4	Surround Left	25.92mV (±5%)	VR86
5	Surround Right	25.92mV (±5%)	VR87
6	Surround Back Left	25.92mV (±5%)	VR82
7	Surround Back Right	25.92mV (±5%)	VR81(ONLY AVR240/340)

# harman/kardon

# TECH TIPS

## Troubleshooting tips and solutions to common service problems

For models:

TIP# HKTT2003-01 Rev6

AVR7000/7200/7300/8000	AVR10
AVR100/200/300/500	DPR1001
AVR110/210/310/510	DPR1005
AVR120/220/320/520	DPR2005
AVR125/225/325/525	HK3370/3470/3375/3475
AVR130/230/330/430/630	HK3250
AVR135/235/335/435/635	
AVR140/240	

**Subject:** Backup Memory on AVR/DPR/HK series receivers

**In the event of the complaint: “the receiver is losing its memory (any programmed system settings) when the unit is turned off, or after the unit is unplugged (briefly\*)”:**

Check and replace:

Model	Designator	Location	Description	Part number
AVR10	C712 D709	Front PCB	0.047 Farad 5.5v capacitor and 1N4148 diode	#3439247315 #2058322101
AVR7000	C730	Front PCB	0.047 Farad 5.5v capacitor	# P10790-ND or # J3432147324X
AVR7200	C106	Front PCB	0.047 Farad 5.5v capacitor	# P10790-ND
AVR7300	C657	DSP PCB	0.047 Farad 5.5v capacitor	# H01-CEZXA0479MN-5
AVR8000	C726	Front PCB	0.047 Farad 5.5v capacitor	# 55230310NR or # P10790-ND
AVR100/200	C412	Front PCB	0.047 Farad 5.5v capacitor	# CEGT-B473J-0J0
AVR300	C906	Front PCB	0.1Farad 5.5v capacitor	# J4433210421X or # P10791-ND
AVR500	C906	Front PCB	0.1Farad 5.5v capacitor	# J4433210421X or # P10791-ND
AVR110/210/310/510 AVR120/220/320/520	C216	Front PCB	0.047 Farad 5.5v capacitor	# P10790-ND
AVR125/225	C734,C885	Front PCB	two 0.1F capacitors in parallel	# BCESOHD104
AVR325/525	C106	Front PCB	0.047 Farad 5.5v capacitor	# P10790-ND
AVR130/230/330	BAT1	Front PCB	3.6v Battery	# HABGP40BVH3A3H
AVR135/235/335	BAT1	Front PCB	3.6v Battery	# HGP15BNH3A3H
AVR140/240	BAT1	Front PCB	3.6v Battery	# HABGP40BVH3A3H
AVR430/630	C657	DSP PCB	0.047 Farad 5.5v capacitor	# CEZXA0479MN-5
AVR435/635	C557	DSP PCB	0.047 Farad 5.5v capacitor	# H03-CEZXA0479MN-0
DPR1001	BC601	Main PCB	0.1Farad 5.5v capacitor	# CEGT-B104J-0J0
DPR1005/2005	C437	Processor PCB	0.047 Farad 5.5v capacitor	# CEZXA0479MN-5
HK3370/3470	C301	Front PCB	0.1Farad 5.5v capacitor	# CEGT-B104J-0J0
HK3375/3475	C301	Front PCB	0.1Farad 5.5v capacitor	# CEGT-B104J-0J0
HK3250	C712 D709	Front PCB	0.047 Farad 5.5v capacitor and 1N4148 diode	#3439247315 #2058322101

\* After approximately two weeks of being disconnected from AC supply, even a normally functioning receiver may lose any programmed settings and switch to default settings. (Four weeks for the DPR1005 & 2005)

6

5

4

3

2

1

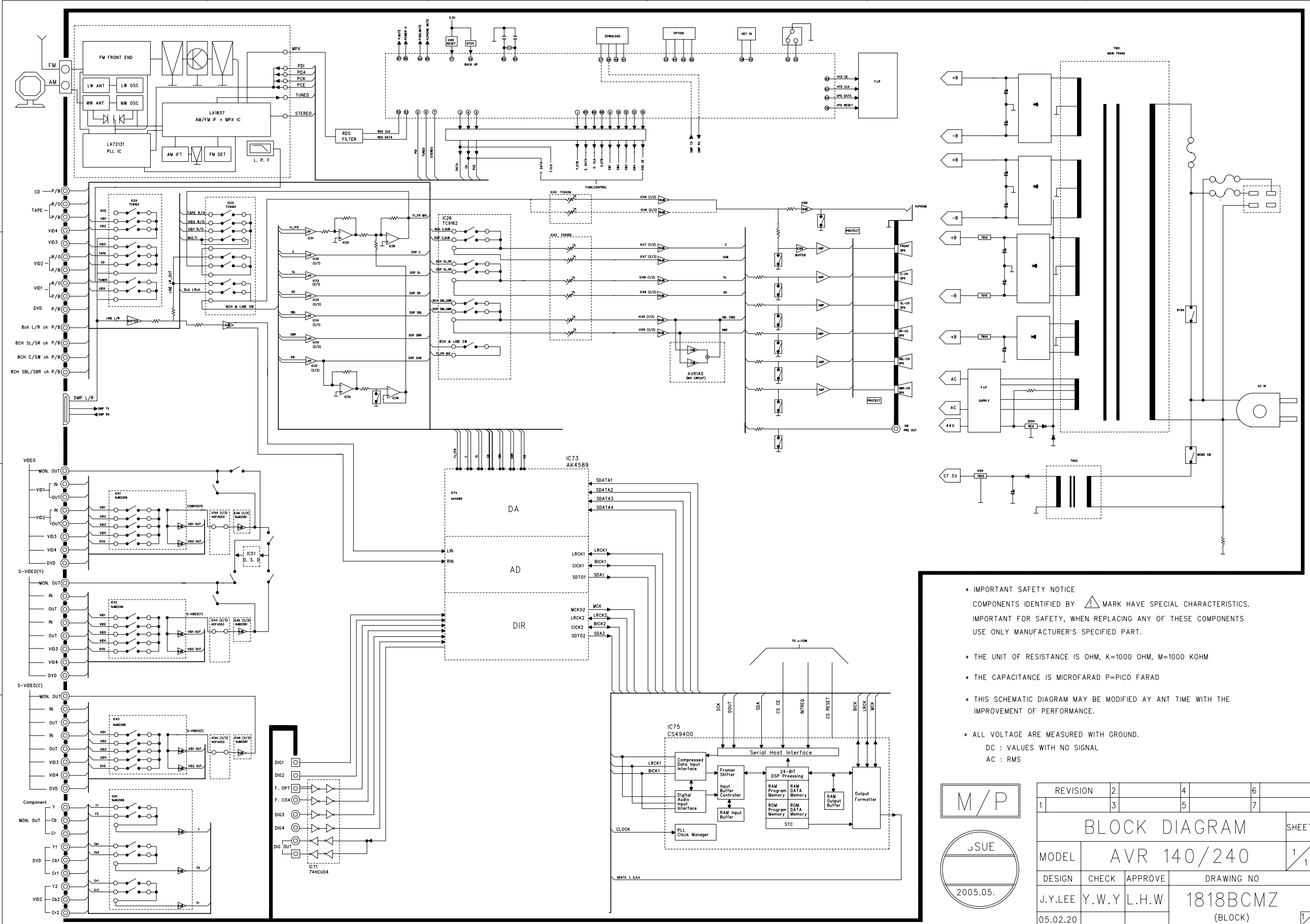

\* IMPORTANT SAFETY NOTICE  
COMPONENTS IDENTIFIED BY MARK HAVE SPECIAL CHARACTERISTICS. IMPORTANT FOR SAFETY, WHEN REPLACING ANY OF THESE COMPONENTS USE ONLY MANUFACTURER'S SPECIFIED PART.

\* THE UNIT OF RESISTANCE IS OHM, K=1000 OHM, M=1000 KOHM

\* THE CAPACITANCE IS MICROFARAD P=PICO FARAD

\* THIS SCHEMATIC DIAGRAM MAY BE MODIFIED AT ANY TIME WITH THE IMPROVEMENT OF PERFORMANCE.

\* ALL VOLTAGE ARE MEASURED WITH GROUND.  
DC : VALUES WITH NO SIGNAL  
AC : RMS

M/P

JSUE  
2005.05.

REVISION	2	4	6
1	3	5	7
BLOCK DIAGRAM			
MODEL	AVR 140/240		
DESIGN	CHECK	APPROVE	DRAWING NO
J.Y.LEE	Y.W.Y	L.H.W	1818BCMZ
05.02.20			(BLOCK)

# MAIN BOARD 1 (AMP)

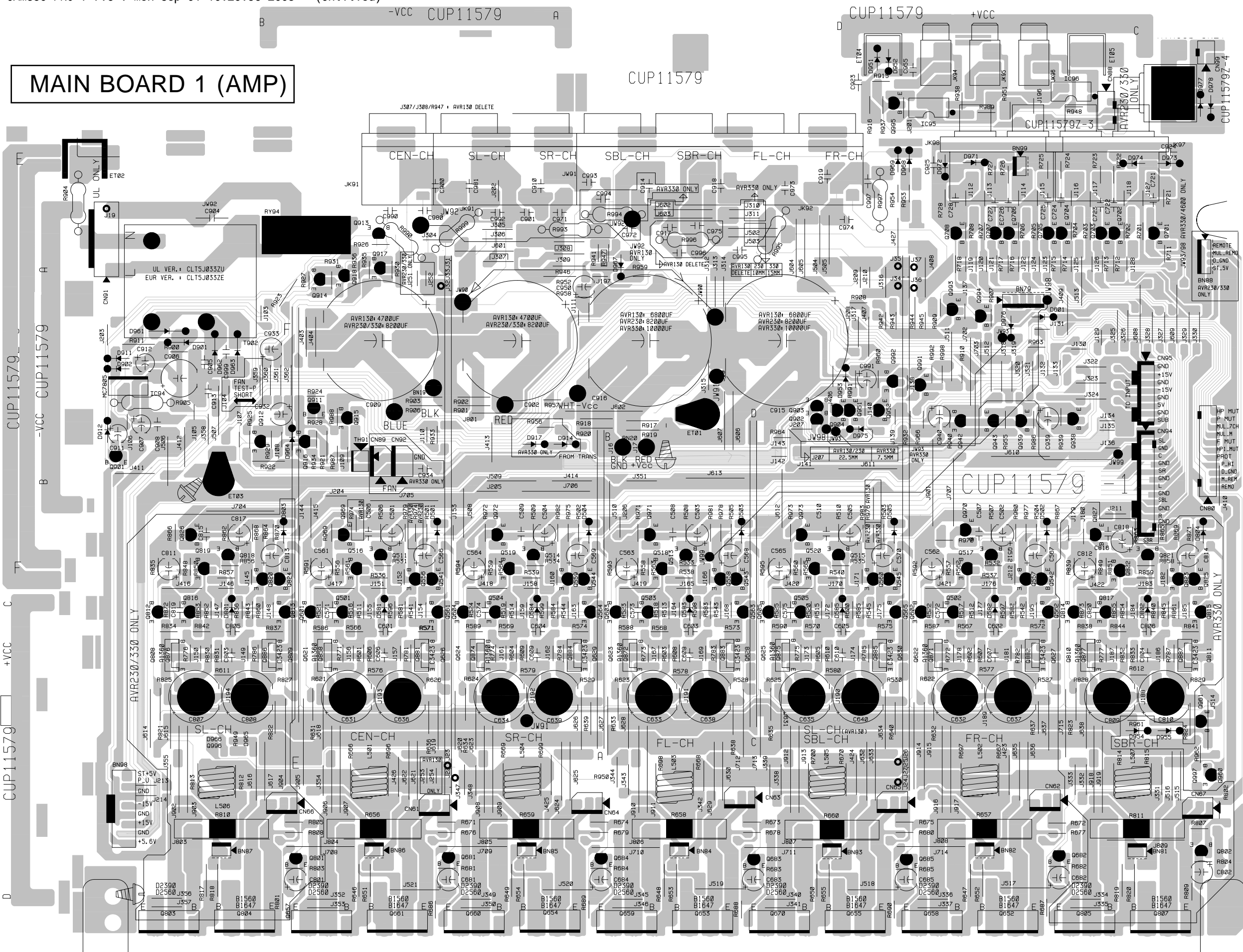

AVR140

harman/kardon

J21



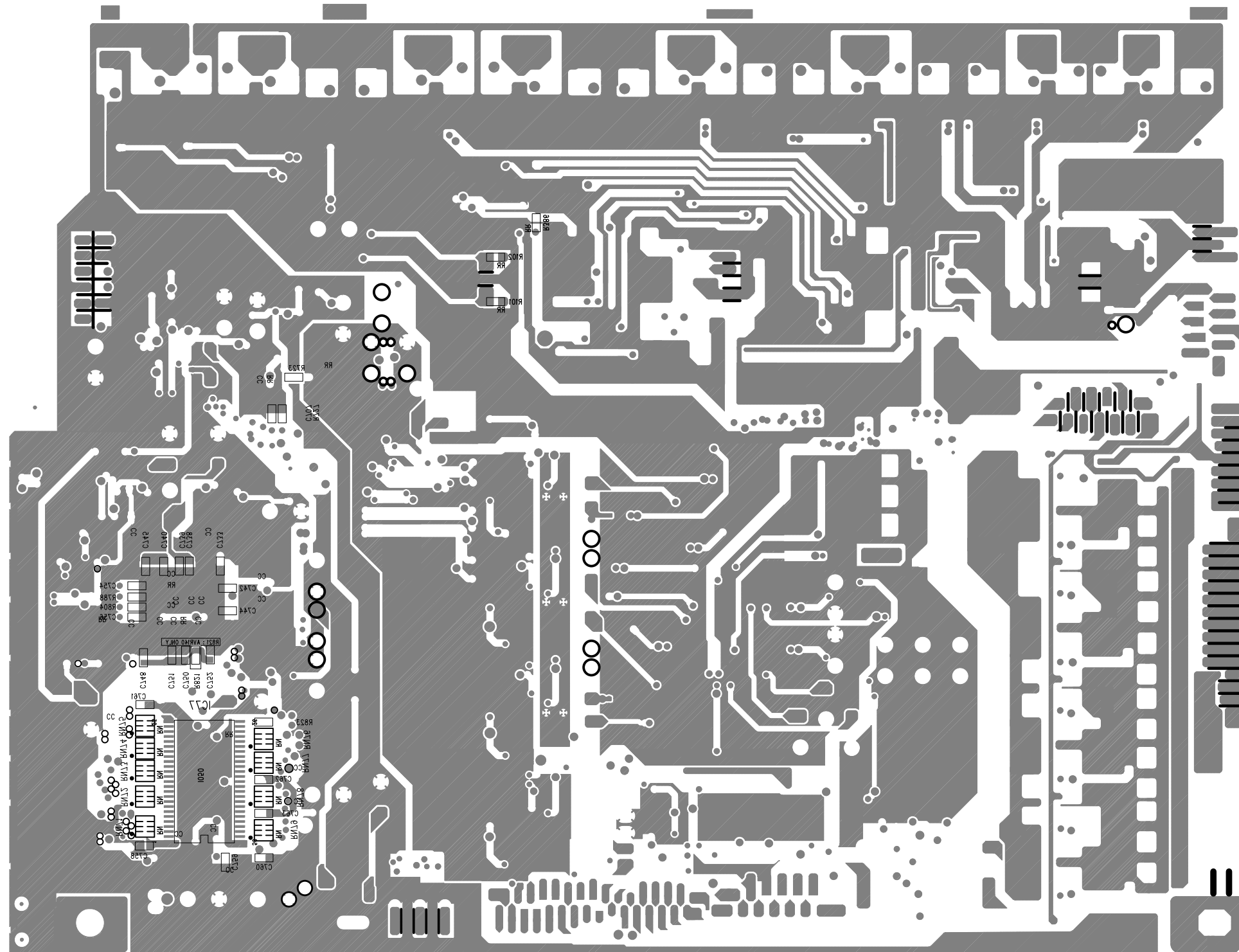



Modify : 2005.08.04

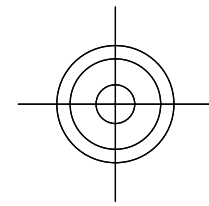
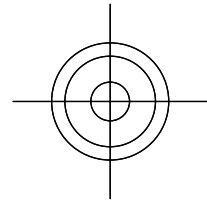

DIPPING

IC	ICT	ADJ1	ADJ2	RP

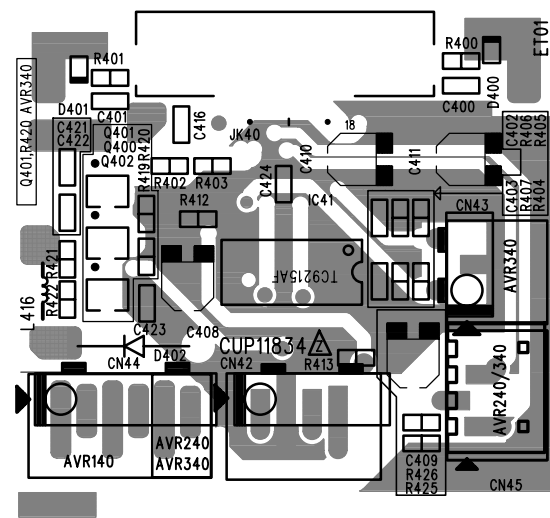

CUP11834

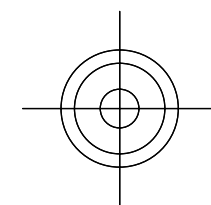
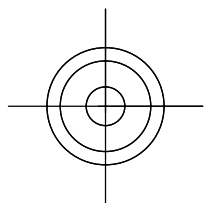

harman/kardon

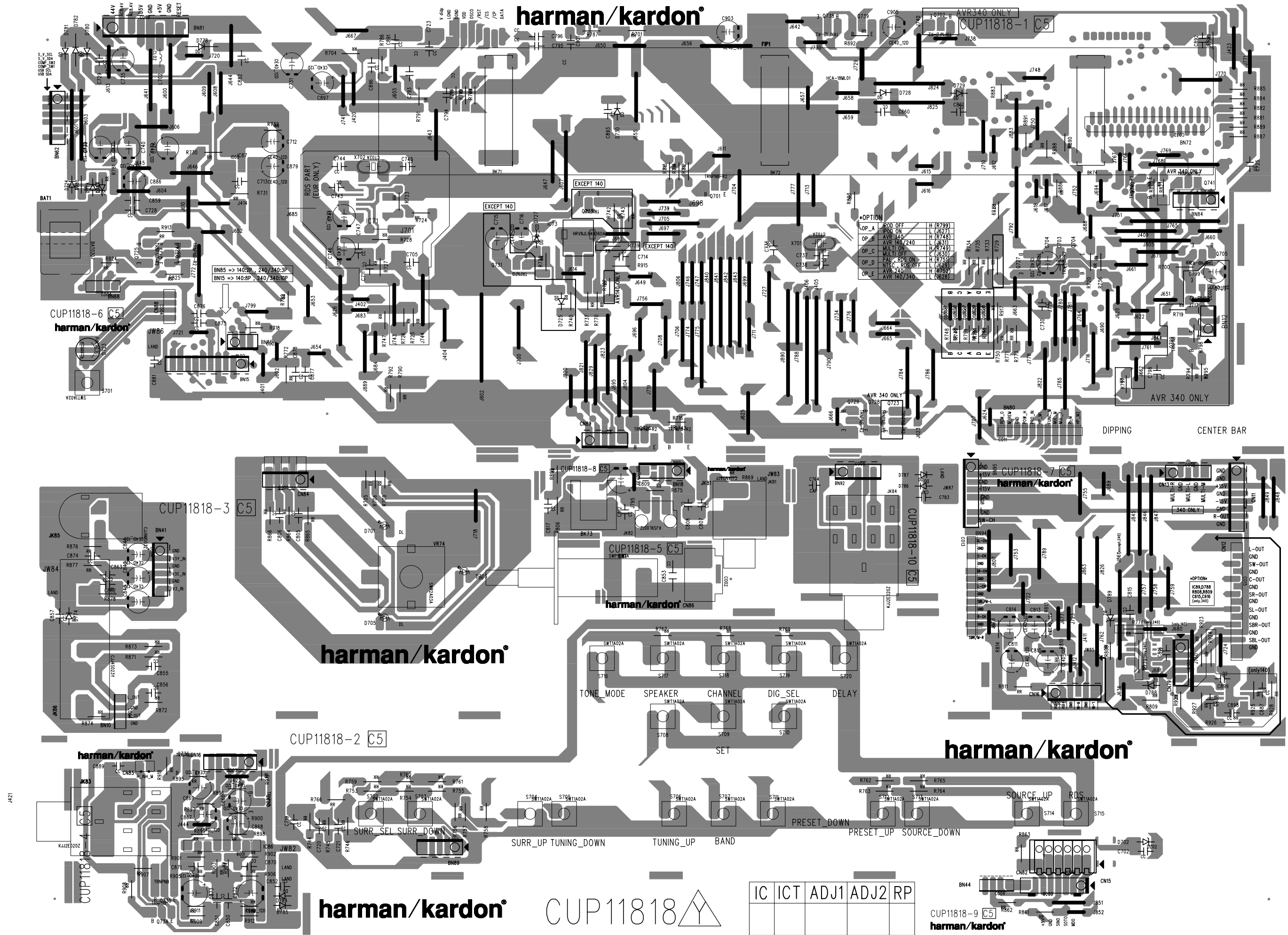

CUP11816

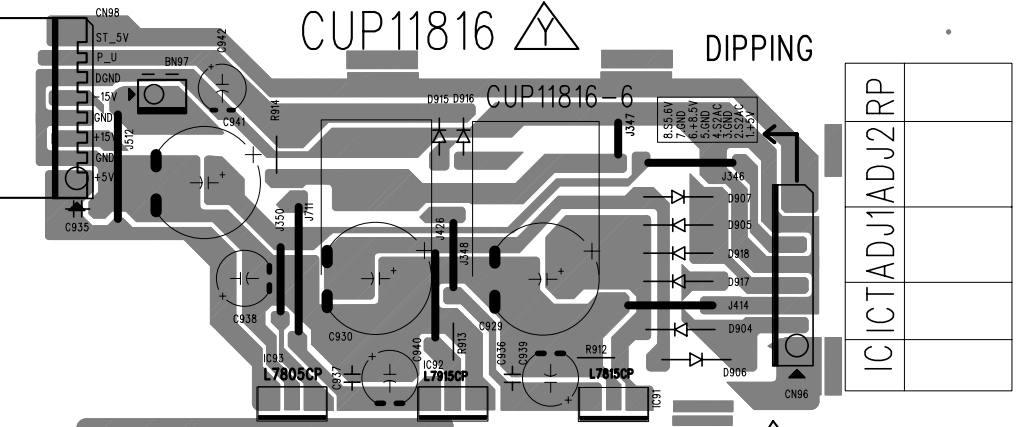
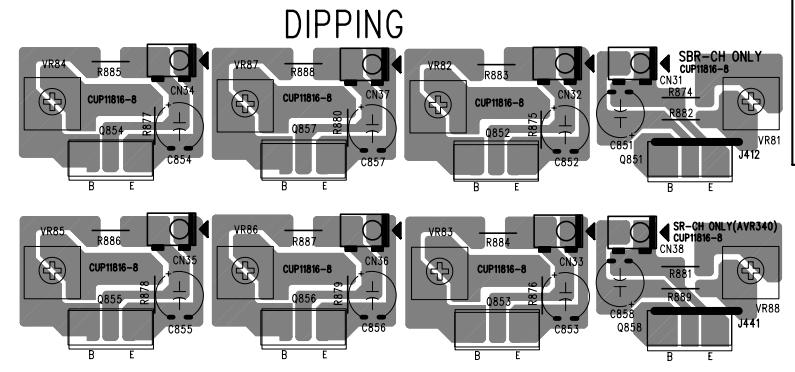

CUP11816

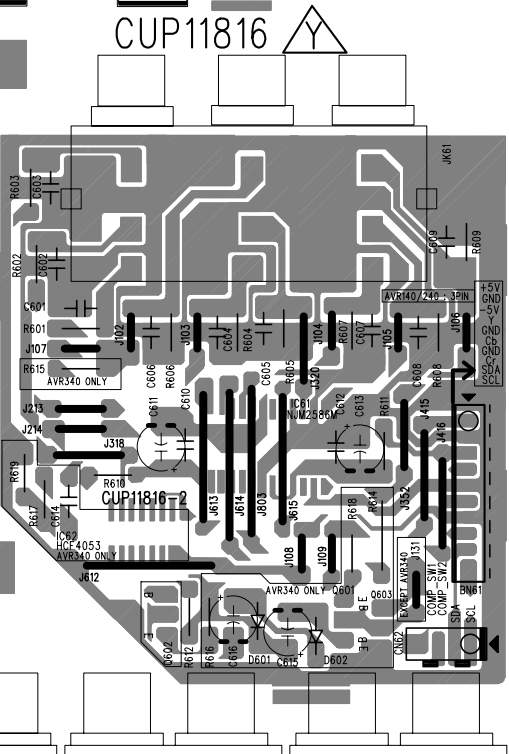
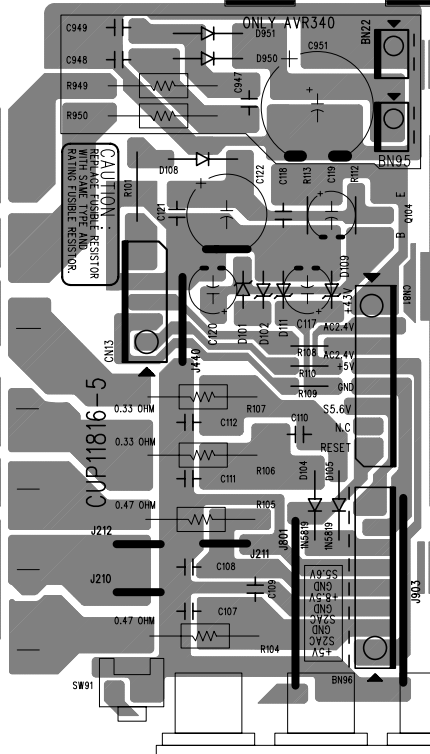
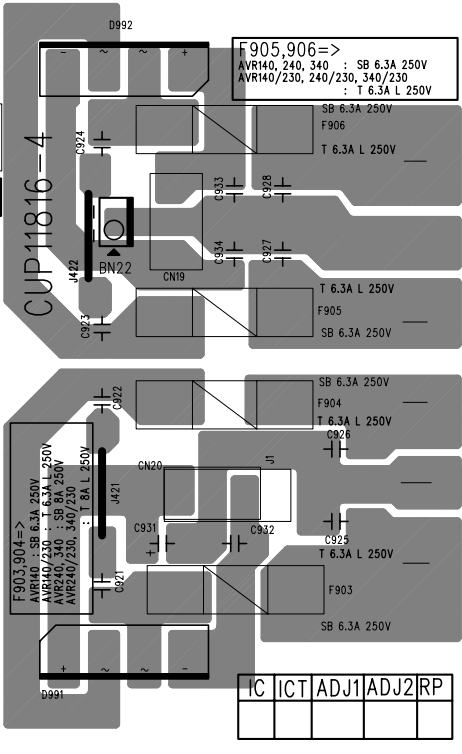
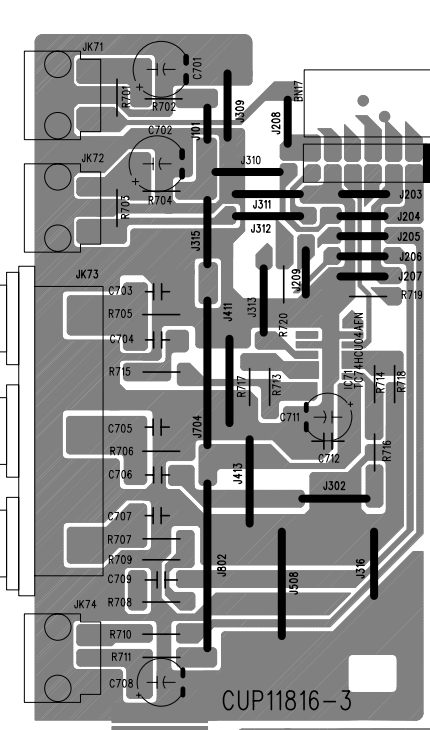

CUP11816

CENTER BAR

CENTER BAR

CUP11816

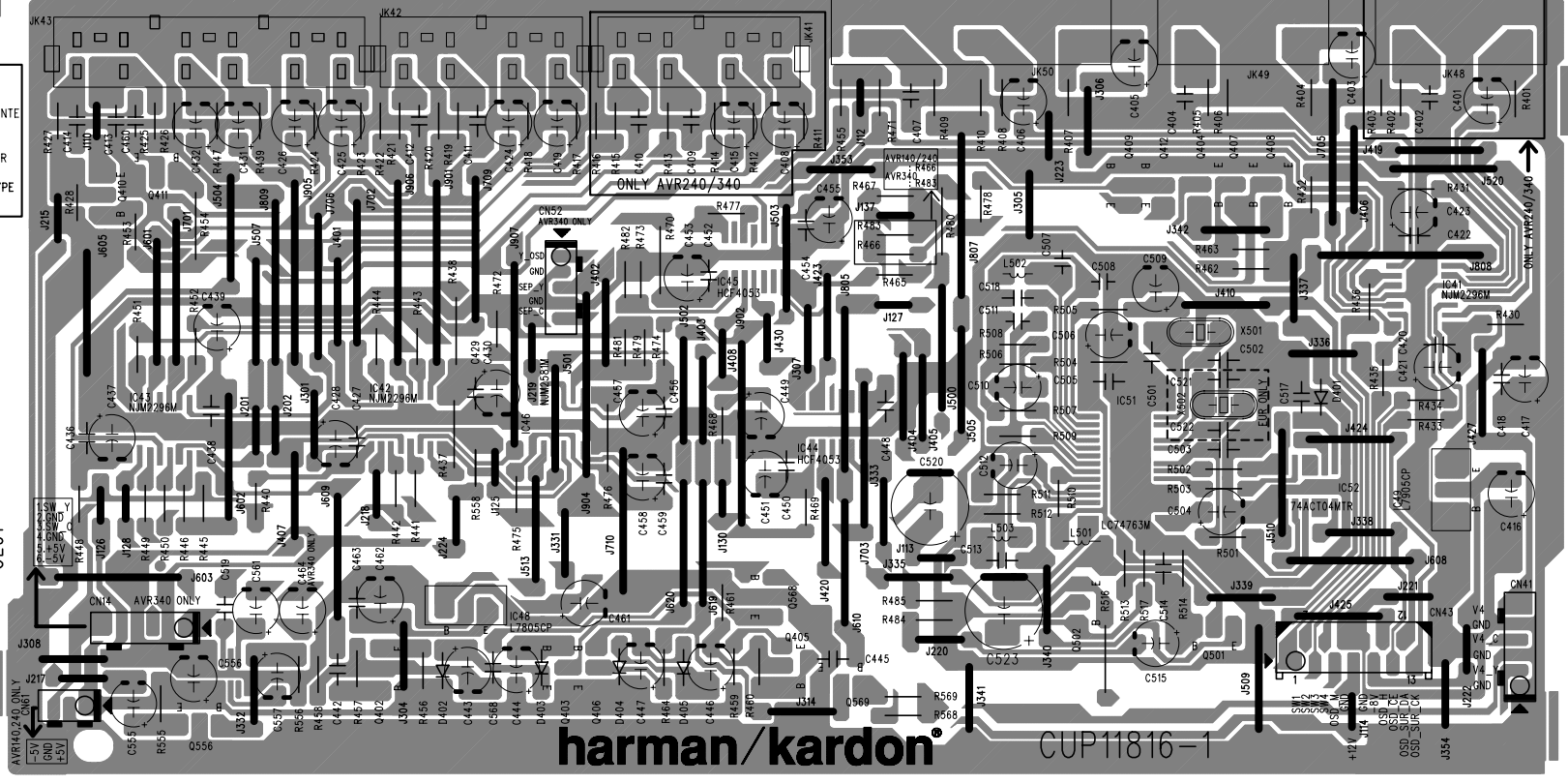
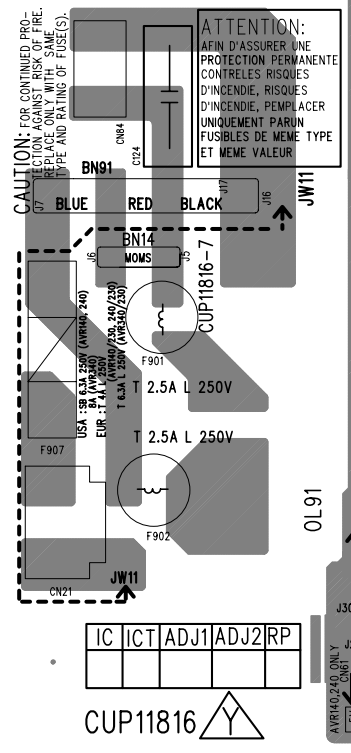

<b>AVR140 Electrical Parts List</b>				
Ref. Designator	Part Number	Description		Qty
<b>FRONT &amp; INTERFACE PCB ASSY'S</b>				
<i>Capacitors</i>				
C703	HCBS1H821KBT	CAP , CERAMIC	820PF 50V K	1
C704	CCEA1VH100T	CAP , ELECT	10UF 35V	1
C712	CCEA1HH1R0T	CAP , ELECT	1UF 50V	1
C713	HCBS1H223ZFT	CAP , CERAMIC	0.022UF 50V Z	1
C714	HCBS1H151KBT	CAP , CERAMIC	150PF 50V K	1
C716	CCEA1CH331T	CAP , ELECT	330UF 16V	1
C719	HCBS1H181KBT	CAP , CERAMIC	180PF 50V K	1
C720	HCBS1H181KBT	CAP , CERAMIC	180PF 50V K	1
C721	HCBS1H181KBT	CAP , CERAMIC	180PF 50V K	1
C723	HCBS1H104ZFT	CAP , CERAMIC	0.1UF 50V Z	1
C725	HCBS1H473ZFT	CAP , CERAMIC	0.047UF 50V Z	1
C726	CCEA1CH101T	CAP , ELECT	100UF 16V	1
C728	HCBS1H104ZFT	CAP , CERAMIC	0.1UF 50V Z	1
C729	CCKT1H473ZF	CAP , CERAMIC	0.047UF 50V ZF	1
C730	CCFT1H104ZF	CAP , SEMICONDUCTOR	0.1UF 50V ZF	1
C731	CCEA1HH100T	CAP , ELECT	10UF 50V	1
C735	CCEA1CH101T	CAP , ELECT	100UF 16V	1
C736	HCBS1H223ZFT	CAP , CERAMIC	0.022UF 50V Z	1
C737	HCBS1H180JCT	CAP , CERAMIC	18PF 50V J	1
C738	HCBS1H180JCT	CAP , CERAMIC	18PF 50V J	1
C739	CCEA1AH221T	CAP , ELECT	220UF/10V	1
C740	CCEA1VH100T	CAP , ELECT	10UF 35V	1
C793	HCBS1H104ZFT	CAP , CERAMIC	0.1UF 50V Z	1
C794	HCBS1H102KBT	CAP , CERAMIC	1000PF 50V B	1
C795	HCBS1H221KBT	CAP , CERAMIC	220PF 50V K	1
C796	HCBS1H101KBT	CAP , CERAMIC	100PF 50V K	1
C805	HCBS1H223ZFT	CAP , CERAMIC	0.022UF 50V Z	1
C806	HCBS1H223ZFT	CAP , CERAMIC	0.022UF 50V Z	1
C807	CCFT1H104ZF	CAP , SEMICONDUCTOR	0.1UF 50V ZF	1
C808	CCKT1H181KB	CAP , CERAMIC	180PF 50V KB	1
C809	CCEA1AH471T	CAP , ELECT	470UF 10V	1
C810	CCEA1CH101T	CAP , ELECT	100UF 16V	1
C811	CCEA1CH101T	CAP , ELECT	100UF 16V	1
C812	HCBS1H104ZFT	CAP , CERAMIC	0.1UF 50V Z	1
C813	CCEA1VH100T	CAP , ELECT	10UF 35V	1
C814	CCEA1VH100T	CAP , ELECT	10UF 35V	1
C817	HCBS1H100JCT	CAP , CERAMIC	10PF 50V J	1
C841	CCEA1VH100T	CAP , ELECT	10UF 35V	1
C842	CCEA1VH100T	CAP , ELECT	10UF 35V	1
C843	CCEA1VH100T	CAP , ELECT	10UF 35V	1
C850	HCBS1H471KBT	CAP , CERAMIC	470PF 50V	1
C851	HCBS1H471KBT	CAP , CERAMIC	470PF 50V	1
C852	HCBS1H104ZFT	CAP , CERAMIC	0.1UF 50V Z	1
C855	HCBS1H101KBT	CAP , CERAMIC	100PF 50V K	1
C856	HCBS1H101KBT	CAP , CERAMIC	100PF 50V K	1
C857	HCBS1H104ZFT	CAP , CERAMIC	0.1UF 50V Z	1
C859	HCBS1H223ZFT	CAP , CERAMIC	0.022UF 50V Z	1
C860	HCBS1H223ZFT	CAP , CERAMIC	0.022UF 50V Z	1
C861	HCBS1H223ZFT	CAP , CERAMIC	0.022UF 50V Z	1
C862	HCBS1H101KBT	CAP , CERAMIC	100PF 50V K	1
C863	HCBS1H101KBT	CAP , CERAMIC	100PF 50V K	1
C866	CCEA1CH100T	CAP , ELECT	10UF 25V	1
C867	CCEA1CH100T	CAP , ELECT	10UF 25V	1

Ref. Designator	Part Number	Description		Qty
<b>FRONT &amp; INTERFACE PCB ASSY'S</b>				
C868	CCEA1CH470T	CAP , ELECT	47UF 25V	1
C869	CCEA1CH470T	CAP , ELECT	47UF 25V	1
C870	HCBS1H681KBT	CAP , CERAMIC	680PF 50V	1
C871	HCBS1H681KBT	CAP , CERAMIC	680PF 50V	1
C872	CCEA1CH331T	CAP , ELECT	330UF 16V	1
C873	CCEA1CH331T	CAP , ELECT	330UF 16V	1
C874	HCBS1H101KBT	CAP , CERAMIC	100PF 50V K	1
C875	HCBS1H101KBT	CAP , CERAMIC	100PF 50V K	1
C876	HCBS1H101KBT	CAP , CERAMIC	100PF 50V K	1
C877	HCBS1H473ZFT	CAP , CERAMIC	0.047UF 50V Z	1
C878	HCBS1H473ZFT	CAP , CERAMIC	0.047UF 50V Z	1
C882	HCBS1H104ZFT	CAP , CERAMIC	0.1UF 50V Z	1
C886	CCEA0JH102T	CAP , ELECT	1000UF 6.3V	1
C887	HCBS1H101KBT	CAP , CERAMIC	100PF 50V K	1
C888	HCBS1H101KBT	CAP , CERAMIC	100PF 50V K	1
C889	CCFT1H104ZF	CAP , SEMICONDUCTOR	0.1UF 50V ZF	1
C891	HCBS1H223ZFT	CAP , CERAMIC	0.022UF 50V Z	1
C892	HCBS1H223ZFT	CAP , CERAMIC	0.022UF 50V Z	1
C893	HCBS1H223ZFT	CAP , CERAMIC	0.022UF 50V Z	1
C896	HCBS1H223ZFT	CAP , CERAMIC	0.022UF 50V Z	1
C897	CCEA1AH471T	CAP , ELECT	470UF 10V	1
C898	HCBS1H223ZFT	CAP , CERAMIC	0.022UF 50V Z	1
C899	HCBS1H223ZFT	CAP , CERAMIC	0.022UF 50V Z	1
C901	HCBS1H390JT	CAP , CERAMIC	39PF 50V J	1
C903	CCEA1HKS2R2T	CAP , ELECT	2.2UF 50V KS	1
C905	CCEA1HKS2R2T	CAP , ELECT	2.2UF 50V KS	1
<i>Semiconductors</i>				
D724	HVD1SS133MT	DIODE	1SS133	1
D728	HVD1SS133MT	DIODE	1SS133	1
D729	HVD1SS133MT	DIODE	1SS133	1
D730	HVD1SS133MT	DIODE	1SS133	1
D774	HVD1SS133MT	DIODE	1SS133	1
D778	KVD1N4003ST	DIODE	1N4003	1
D779	HVD1SS133MT	DIODE	1SS133	1
D780	HVD1SS133MT	DIODE	1SS133	1
D781	HVD1SS133MT	DIODE	1SS133	1
D782	KVD1N4003ST	DIODE	1N4003	1
D783	HVD1SS133MT	DIODE	1SS133	1
D784	HVD1SS133MT	DIODE	1SS133	1
D785	HVD1SS133MT	DIODE	1SS133	1
IC87	HVIRE5VL28CATZ	IC , RESET	RICOH	1
Q701	HVTKRC107MT	TRANSISTOR	KRC107M	1
Q705	HVTKRC107MT	TRANSISTOR	KRC107M	1
Q722	HVTKRA107MT	TRANSISTOR	KRA107M	1
Q724	HVTKRC107MT	TRANSISTOR	KRC107M	1
Q725	HVTKRC107MT	TRANSISTOR	KRC107M	1
Q726	HVTKRC107MT	TRANSISTOR	KRC107M	1
Q727	HVTKRC107MT	TRANSISTOR	KRC107M	1
Q728	HVTKRC107MT	TRANSISTOR	KRC107M	1
Q729	HVTKRC107MT	TRANSISTOR	KRC107M	1
Q734	HVTKTC2874BT	TRANSISTOR , MUTE	KTC2874B	1
Q735	HVTKTC2874BT	TRANSISTOR , MUTE	KTC2874B	1
Q736	HVTKTC2874BT	TRANSISTOR , MUTE	KTC2874B	1
Q737	HVTKTC2874BT	TRANSISTOR , MUTE	KTC2874B	1
Q738	HVTKRC107MT	TRANSISTOR	KRC107M	1
Q739	HVTKTA1271YT	TRANSISTOR	KTA1271Y	1

Ref. Designator	Part Number	Description		Qty
<b>FRONT &amp; INTERFACE PCB ASSY'S</b>				
Q740	HVTKRC107MT	TRANSISTOR	KRC107M	1
Q743	HVTKRA107MT	TRANSISTOR	KRA107M	1
D701	CVD52CSBBCEAB2	BLUE L.E.D	L.E.D	1
D703	CVD52CSBBCEAB2	BLUE L.E.D	L.E.D	1
D705	CVD52CSBBCEAB2	BLUE L.E.D	L.E.D	1
D723	CVD50BOBBWGA	L.E.D , 2 COLOR (ORG , BLUE)	L.E.D	1
IC72	BVIMB90F482APFG	IC , FLASH U-COM	FUJITSU	1
IC73	HRVNJL34H380A	SENSOR , REMOTE	SENSOR	1
IC75	HVI74ACT04MTR	I.C , HEX	FAIRCHILD	1
IC76	HVI74HCU04AFNG	I.C , INVERTER	TOSHIBA	1
IC83	HVI74ACT04MTR	I.C , HEX	FAIRCHILD	1
IC84	HVI74ACT04MTR	I.C , HEX	FAIRCHILD	1
IC85	HVIRH5VT18C	I.C , RESET	RICOH	1
IC86	HVINJM4556AL	I.C , HEADPHONE	JRC	1
IC88	HVINJM2068MDTE1	I.C , OP AMP	JRC	1
IC90	HVINJM2068MDTE1	I.C , OP AMP	JRC	1
<i>Resistors</i>				
R700	CRD20TJ102T	RES , CARBON	1K OHM 1/5W J	1
R701	CRD20TJ103T	RES , CARBON	10K OHM 1/5W J	1
R704	CRD20TJ100T	RES , CARBON	10 OHM 1/5W J	1
R705	CRD20TJ820T	RES , CARBON	82 OHM 1/5W J	1
R706	CRD20TJ820T	RES , CARBON	82 OHM 1/5W J	1
R708	CRD20TJ820T	RES , CARBON	82 OHM 1/5W J	1
R709	CRD20TJ470T	RES , CARBON	47 OHM 1/5W J	1
R710	CRD20TJ470T	RES , CARBON	47 OHM 1/5W J	1
R711	CRD20TJ470T	RES , CARBON	47 OHM 1/5W J	1
R712	CRD20TJ102T	RES , CARBON	1K OHM 1/5W J	1
R713	CRD20TJ102T	RES , CARBON	1K OHM 1/5W J	1
R714	CRD20TJ102T	RES , CARBON	1K OHM 1/5W J	1
R716	CRD20TJ102T	RES , CARBON	1K OHM 1/5W J	1
R718	CRD20TJ222T	RES , CARBON	2.2K OHM 1/5W J	1
R722	CRD20TJ1R0T	RES , CARBON	1 OHM 1/5W J	1
R730	CRD20TJ112T	RES , CARBON	1.1K OHM 1/5W J	1
R731	CRD20TJ223T	RES , CARBON	22K OHM 1/5W J	1
R732	CRD20TJ222T	RES , CARBON	2.2K OHM 1/5W J	1
R733	CRD20TJ272T	RES , CARBON	2.7K OHM 1/5W J	1
R734	CRD20TJ103T	RES , CARBON	10K OHM 1/5W J	1
R735	CRD20TJ103T	RES , CARBON	10K OHM 1/5W J	1
R736	CRD20TJ272T	RES , CARBON	2.7K OHM 1/5W J	1
R737	CRD20TJ100T	RES , CARBON	10 OHM 1/5W J	1
R744	CRD20TF1002T	RES , CARBON	10K F 1/5W	1
R745	CRD20TF1002T	RES , CARBON	10K F 1/5W	1
R746	CRD20TF1002T	RES , CARBON	10K F 1/5W	1
R747	CRD20TJ103T	RES , CARBON	10K OHM 1/5W J	1
R750	CRD20TJ223T	RES , CARBON	22K OHM 1/5W J	1
R753	CRD20TJ102T	RES , CARBON	1K OHM 1/5W J	1
R754	CRD20TJ152T	RES , CARBON	1.5K OHM 1/5W J	1
R755	CRD20TJ182T	RES , CARBON	1.8K OHM 1/5W J	1
R756	CRD20TJ272T	RES , CARBON	2.7K OHM 1/5W J	1
R757	CRD20TJ332T	RES , CARBON	3.3K OHM 1/5W J	1
R758	CRD20TJ562T	RES , CARBON	5.6K OHM 1/5W J	1
R759	CRD20TJ102T	RES , CARBON	1K OHM 1/5W J	1
R760	CRD20TJ152T	RES , CARBON	1.5K OHM 1/5W J	1
R761	CRD20TJ182T	RES , CARBON	1.8K OHM 1/5W J	1
R762	CRD20TJ272T	RES , CARBON	2.7K OHM 1/5W J	1
R763	CRD20TJ332T	RES , CARBON	3.3K OHM 1/5W J	1



Ref. Designator	Part Number	Description		Qty
<b>FRONT &amp; INTERFACE PCB ASSY'S</b>				
R764	CRD20TJ562T	RES , CARBON	5.6K OHM 1/5W J	1
R765	CRD20TJ752T	RES , CARBON	7.5K OHM 1/5W J	1
R766	CRD20TJ102T	RES , CARBON	1K OHM 1/5W J	1
R767	CRD20TJ152T	RES , CARBON	1.5K OHM 1/5W J	1
R768	CRD20TJ182T	RES , CARBON	1.8K OHM 1/5W J	1
R769	CRD20TJ272T	RES , CARBON	2.7K OHM 1/5W J	1
R771	CRD20TJ103T	RES , CARBON	10K OHM 1/5W J	1
R772	CRD20TJ103T	RES , CARBON	10K OHM 1/5W J	1
R773	CRD20TJ103T	RES , CARBON	10K OHM 1/5W J	1
R780	CRD20TJ100T	RES , CARBON	10 OHM 1/5W J	1
R781	CRD20TJ123T	RES , CARBON	12K OHM 1/5W J	1
R786	CRD20TJ152T	RES , CARBON	1.5K OHM 1/5W J	1
R787	CRD20TJ101T	RES , CARBON	100 OHM 1/5W J	1
R789	CRD20TJ102T	RES , CARBON	1K OHM 1/5W J	1
R790	CRD20TJ105T	RES , CARBON	1M OHM 1/5W J	1
R791	CRD20TJ822T	RES , CARBON	8.2K OHM 1/5W J	1
R792	CRD20TJ102T	RES , CARBON	1K OHM 1/5W J	1
R805	CRD20TJ104T	RES , CARBON	100K OHM 1/5W J	1
R806	CRD20TJ472T	RES , CARBON	4.7K OHM 1/5W J	1
R810	CRD20TJ101T	RES , CARBON	100 OHM 1/5W J	1
R811	CRD20TJ101T	RES , CARBON	100 OHM 1/5W J	1
R813	CRD20TJ104T	RES , CARBON	100K OHM 1/5W J	1
R814	CRD20TJ104T	RES , CARBON	100K OHM 1/5W J	1
R820	CRD20TJ103T	RES , CARBON	10K OHM 1/5W J	1
R824	CRD20TJ221T	RES , CARBON	220 OHM 1/5W J	1
R825	CRD20TJ681T	RES , CARBON	680 OHM 1/5W J	1
R861	CRD20TJ101T	RES , CARBON	100 OHM 1/5W J	1
R862	CRD20TJ471T	RES , CARBON	470 OHM 1/5W J	1
R864	CRD20TJ272T	RES , CARBON	2.7K OHM 1/5W J	1
R865	CRD20TJ101T	RES , CARBON	100 OHM 1/5W J	1
R866	CRD20TJ272T	RES , CARBON	2.7K OHM 1/5W J	1
R869	CRD20TJ750T	RES , CARBON	75 OHM 1/5W J	1
R871	CRD20TJ104T	RES , CARBON	100K OHM 1/5W J	1
R872	CRD20TJ104T	RES , CARBON	100K OHM 1/5W J	1
R873	CRD20TJ471T	RES , CARBON	470 OHM 1/5W J	1
R874	CRD20TJ471T	RES , CARBON	470 OHM 1/5W J	1
R875	CRD20TJ103T	RES , CARBON	10K OHM 1/5W J	1
R876	CRD20TJ750T	RES , CARBON	75 OHM 1/5W J	1
R877	CRD20TJ750T	RES , CARBON	75 OHM 1/5W J	1
R878	CRD20TJ750T	RES , CARBON	75 OHM 1/5W J	1
R881	CRD20TJ103T	RES , CARBON	10K OHM 1/5W J	1
R882	CRD20TJ103T	RES , CARBON	10K OHM 1/5W J	1
R883	CRD20TJ103T	RES , CARBON	10K OHM 1/5W J	1
R884	CRD20TJ103T	RES , CARBON	10K OHM 1/5W J	1
R885	CRD20TJ103T	RES , CARBON	10K OHM 1/5W J	1
R886	CRD20TJ103T	RES , CARBON	10K OHM 1/5W J	1
R887	CRD20TJ103T	RES , CARBON	10K OHM 1/5W J	1
R888	CRD20TJ103T	RES , CARBON	10K OHM 1/5W J	1
R889	CRD20TJ103T	RES , CARBON	10K OHM 1/5W J	1
R890	CRD20TJ103T	RES , CARBON	10K OHM 1/5W J	1
R891	CRD20TJ103T	RES , CARBON	10K OHM 1/5W J	1
R892	CRD20TJ222T	RES , CARBON	2.2K OHM 1/5W J	1
R893	CRD20TJ333T	RES , CARBON	33K OHM 1/5W J	1
R895	CRD20TJ101T	RES , CARBON	100 OHM 1/5W J	1
R896	CRD20TJ101T	RES , CARBON	100 OHM 1/5W J	1
R897	CRD20TJ101T	RES , CARBON	100 OHM 1/5W J	1
R898	CRD20TJ101T	RES , CARBON	100 OHM 1/5W J	1
R899	CRD20TJ104T	RES , CARBON	100K OHM 1/5W J	1

Ref. Designator	Part Number	Description		Qty
<b>FRONT &amp; INTERFACE PCB ASSY'S</b>				
R900	CRD20TJ104T	RES , CARBON	100K OHM 1/5W J	1
R901	CRD20TJ152T	RES , CARBON	1.5K OHM 1/5W J	1
R902	CRD20TJ152T	RES , CARBON	1.5K OHM 1/5W J	1
R903	CRD20TJ102T	RES , CARBON	1K OHM 1/5W J	1
R904	CRD20TJ102T	RES , CARBON	1K OHM 1/5W J	1
R905	CRD20TJ104T	RES , CARBON	100K OHM 1/5W J	1
R906	CRD20TJ104T	RES , CARBON	100K OHM 1/5W J	1
R907	CRD20TJ562T	RES , CARBON	5.6K OHM 1/5W J	1
R908	CRD20TJ562T	RES , CARBON	5.6K OHM 1/5W J	1
R909	CRD20TJ221T	RES , CARBON	220 OHM 1/5W J	1
R910	CRD20TJ221T	RES , CARBON	220 OHM 1/5W J	1
R911	CRD20TJ221T	RES , CARBON	220 OHM 1/5W J	1
R912	CRD20TJ221T	RES , CARBON	220 OHM 1/5W J	1
R913	CRD20TJ102T	RES , CARBON	1K OHM 1/5W J	1
R915	CRD20TJ473T	RES , CARBON	47K OHM 1/5W J	1
R918	CRD20TJ562T	RES , CARBON	5.6K OHM 1/5W J	1
R919	CRD20TJ562T	RES , CARBON	5.6K OHM 1/5W J	1
R923	CRD20TJ332T	RES , CARBON	3.3K OHM 1/5W J	1
R924	CRD20TJ332T	RES , CARBON	3.3K OHM 1/5W J	1
R925	CRD20TJ242T	RES , CARBON	2.4K OHM 1/5W J	1
R926	CRD20TJ332T	RES , CARBON	3.3K OHM 1/5W J	1
R927	CRD20TJ332T	RES , CARBON	3.3K OHM 1/5W J	1
R928	CRD20TJ121T	RES , CARBON	120 OHM 1/5W J	1
R929	CRD20TJ121T	RES , CARBON	120 OHM 1/5W J	1
<i>Miscellaneous</i>				
L702	HLQ02C100KT	COIL , AXAIL	10UH	1
FIP1	HFLHCA18ML03	F.I.P	FIP	1
VR74	CSR2A037Z	ENCODER	ENCODER	1
S701	HST1A020ZT	SW , TACT	1A020	1
S702	HST1A020ZT	SW , TACT	1A020	1
S703	HST1A020ZT	SW , TACT	1A020	1
S704	HST1A020ZT	SW , TACT	1A020	1
S705	HST1A020ZT	SW , TACT	1A020	1
S706	HST1A020ZT	SW , TACT	1A020	1
S707	HST1A020ZT	SW , TACT	1A020	1
S708	HST1A020ZT	SW , TACT	1A020	1
S709	HST1A020ZT	SW , TACT	1A020	1
S710	HST1A020ZT	SW , TACT	1A020	1
S711	HST1A020ZT	SW , TACT	1A020	1
S712	HST1A020ZT	SW , TACT	1A020	1
S713	HST1A020ZT	SW , TACT	1A020	1
S714	HST1A020ZT	SW , TACT	1A020	1
S715	HST1A020ZT	SW , TACT	1A020	1
S716	HST1A020ZT	SW , TACT	1A020	1
S717	HST1A020ZT	SW , TACT	1A020	1
S718	HST1A020ZT	SW , TACT	1A020	1
S719	HST1A020ZT	SW , TACT	1A020	1
S720	HST1A020ZT	SW , TACT	1A020	1
BAT1	HABGP40BVH3A3H	BATTERY , RECHARGEABLE	BATTERY	1
BK71	CMD1A209	BRACKET , FLT	BRACKET	1
BK72	CMD1A209	BRACKET , FLT	BRACKET	1
BK73	CMD1A387	BRACKET , PCB	BRACKET	1
BK74	CMD1A209	BRACKET , FLT	BRACKET	1
BN10	CWZAVR230BN10	WIRE ASS'Y (SHIELD)	WIRE	1
BN15	CWB2B908150EN	WIRE ASS'Y	WIRE	1
BN16	CWZAVR140BN16	WIRE ASS'Y (SHIELD)	WIRE	1

Ref. Designator	Part Number	Description		Qty
<b>FRONT &amp; INTERFACE PCB ASSY'S</b>				
BN18	CWZAVR125BN18	WIRE ASS'Y (SHIELD)	WIRE	1
BN41	CWZAVR130BN41	WIRE ASS'Y (SHIELD)	WIRE	1
BN44	CWB2B904350EN	WIRE ASS'Y	WIRE	1
BN62	CWB2B904370EN	WIRE ASS'Y	WIRE	1
BN72	HJP32GA179ZJ	CONN,FFC 1M/M 32P STR,SMD_JST	CONNECTOR	1
BN80	CWB2B911420EW	WIRE ASS'Y	WIRE	1
BN81	CWB2B908250BM	WIRE , ASS'Y	WIRE	1
BN84	CWB2B905080EN	WIRE ASS'Y	WIRE	1
BN85	CWB2B902090EN	WIRE ASS'Y	WIRE	1
BN88	CWB2B904070EN	WIRE ASS'Y	WIRE	1
BN89	CWB2B905080EN	WIRE ASS'Y	WIRE	1
BN94	KJP13GB99ZM	CONNECTOR	CONNECTOR	1
BN95	KJP08GB99ZM	CONNECTOR , HOUSING	CONNECTOR	1
CN11	KJP08GA98ZM	WAFER	WIRE	1
CN12	KJP15GA98ZM	WAFER	WIRE	1
CN15	CJP08GA19ZY	WAFER, STRAIGHT, 8PIN	WIRE	1
CN16	CJP06GA19ZY	WAFER, STRAIGHT, 6PIN	WIRE	1
CN82	KJP06HA37ZM	WAFER	WIRE	1
CN84	KJP05GB46ZM	WAFER	WIRE	1
CN85	CJP02GA19ZY	WAFER, 2PIN	WIRE	1
CN86	KJP02GA89ZM	WAFER	WIRE	1
CN88	CJP04GA19ZY	WAFER, STRAIGHT, 4PIN	WIRE	1
CN89	CJP05GA19ZY	WAFER, STRAIGHT, 5PIN	WIRE	1
JK81	CJJ4M041Y	JACK , BOARD (COAX)	COAXIAL JACK	1
JK82	HJSTORX177L	MODULE , OPTICAL(RX)	OPTICAL JACK	1
JK83	CJJ2E026Z	JACK , HEADPHONE(SILVER PLATE)	HEADPHONE JACK	1
JK85	CJJ9M003Z	JACK , S-VIDEO	S-VIDEO JACK	1
JK86	CJJ4S023Y	JACK , BOARD	JACK	1
JW82	CWZAVR2550JW82	WIRE , ASS'Y	WIRE	1
JW83	CWE8202150RV	WIRE ASS'Y	WIRE	1
JW84	CWE8202110RV	WIRE, ASS'Y	WIRE	1
JW85	CWE8202070AA	WIRE ASS'Y	WIRE	1
SW1	CSH1A008ZV	SW , PUSH (MOMS)	MOMS SWITCH	1
X701	HOX05000E160C	CRYSTAL	5Mhz	1
	CTB3+10G	SCREW	SCREW	34
	CTB3+16GFZ	SCREW	SCREW	2
	CTWS3+10G	SCREW	SCREW	1
<b>INPUT PCB ASS'Y</b>				
<i>Capacitors</i>				
C105	HCUS1H223KC	CAP , CHIP	0.022uF	1
C106	HCUS1H223KC	CAP , CHIP	0.022uF	1
C201	HCUS1H221JA	CAP , CHIP	220pF	1
C202	HCUS1H221JA	CAP , CHIP	220pF	1
C203	HCUS1H221JA	CAP , CHIP	220pF	1
C204	HCUS1H221JA	CAP , CHIP	220pF	1
C205	HCUS1H221JA	CAP , CHIP	220pF	1
C206	HCUS1H221JA	CAP , CHIP	220pF	1
C211	HCUS1H221JA	CAP , CHIP	220pF	1
C212	HCUS1H221JA	CAP , CHIP	220pF	1
C213	HCUS1H221JA	CAP , CHIP	220pF	1
C214	HCUS1H221JA	CAP , CHIP	220pF	1
C215	HCUS1H221JA	CAP , CHIP	220pF	1
C216	HCUS1H221JA	CAP , CHIP	220pF	1
C217	HCUS1H221JA	CAP , CHIP	220pF	1
C218	HCUS1H221JA	CAP , CHIP	220pF	1

Ref. Designator	Part Number	Description		Qty
<b>INPUT PCB ASS'Y</b>				
C219	HCUS1H221JA	CAP , CHIP	220pF	1
C220	HCUS1H221JA	CAP , CHIP	220pF	1
C221	HCUS1H221JA	CAP , CHIP	220pF	1
C222	HCUS1H221JA	CAP , CHIP	220pF	1
C223	HCUS1H221JA	CAP , CHIP	220pF	1
C224	HCUS1H221JA	CAP , CHIP	220pF	1
C225	HCUS1H221JA	CAP , CHIP	220pF	1
C226	HCUS1H221JA	CAP , CHIP	220pF	1
C241	HCUS1H181JA	CAP , CHIP	180pF	1
C242	HCUS1H471JA	CAP , CHIP	470pF	1
C253	HCUS1H181JA	CAP , CHIP	180pF	1
C254	HCUS1H471JA	CAP , CHIP	470pF	1
C255	HCUS1H223KC	CAP , CHIP	0.022uF	1
C256	HCUS1H223KC	CAP , CHIP	0.022uF	1
C270	HCUS1H181JA	CAP , CHIP	180pF	1
C271	HCUS1H471JA	CAP , CHIP	470pF	1
C291	HCUS1H104ZF	CAP , CHIP	0.1uF	1
C292	HCUS1H104ZF	CAP , CHIP	0.1uF	1
C294	HCUS1H104ZF	CAP , CHIP	0.1uF	1
C295	HCUS1H104ZF	CAP , CHIP	0.1uF	1
C296	HCUS1H104ZF	CAP , CHIP	0.1uF	1
C297	HCUS1H104ZF	CAP , CHIP	0.1uF	1
C298	HCUS1H104ZF	CAP , CHIP	0.1uF	1
C309	HCUS1H332KC	CAP , CHIP	3300pF	1
C310	HCUS1H332KC	CAP , CHIP	3300pF	1
C311	HCUS1H332KC	CAP , CHIP	3300pF	1
C312	HCUS1H332KC	CAP , CHIP	3300pF	1
C313	HCUS1H332KC	CAP , CHIP	3300pF	1
C314	HCUS1H332KC	CAP , CHIP	3300pF	1
C315	HCUS1H332KC	CAP , CHIP	3300pF	1
C316	HCUS1H332KC	CAP , CHIP	3300pF	1
C317	HCUS1H223KC	CAP , CHIP	0.022uF	1
C318	HCUS1H223KC	CAP , CHIP	0.022uF	1
C319	HCUS1H223KC	CAP , CHIP	0.022uF	1
C320	HCUS1H223KC	CAP , CHIP	0.022uF	1
C321	HCUS1H561JA	CAP , CHIP	560pF	1
C322	HCUS1H561JA	CAP , CHIP	560pF	1
C323	HCUS1H561JA	CAP , CHIP	560pF	1
C324	HCUS1H561JA	CAP , CHIP	560pF	1
C325	HCUS1H561JA	CAP , CHIP	560pF	1
C326	HCUS1H561JA	CAP , CHIP	560pF	1
C327	HCUS1H561JA	CAP , CHIP	560pF	1
C328	HCUS1H561JA	CAP , CHIP	560pF	1
C329	HCUS1H561JA	CAP , CHIP	560pF	1
C330	HCUS1H561JA	CAP , CHIP	560pF	1
C331	HCUS1H561JA	CAP , CHIP	560pF	1
C332	HCUS1H561JA	CAP , CHIP	560pF	1
C333	HCUS1H561JA	CAP , CHIP	560pF	1
C334	HCUS1H561JA	CAP , CHIP	560pF	1
C335	HCUS1H561JA	CAP , CHIP	560pF	1
C336	HCUS1H561JA	CAP , CHIP	560pF	1
C337	HCUS1H223KC	CAP , CHIP	0.022uF	1
C338	HCUS1H223KC	CAP , CHIP	0.022uF	1
C339	HCUS1H223KC	CAP , CHIP	0.022uF	1
C340	HCUS1H223KC	CAP , CHIP	0.022uF	1
C350	HCUS1H332KC	CAP , CHIP	3300pF	1
C351	HCUS1H332KC	CAP , CHIP	3300pF	1
C352	HCUS1H332KC	CAP , CHIP	3300pF	1

Ref. Designator	Part Number	Description		Qty
<b>INPUT PCB ASS'Y</b>				
C353	HCUS1H332KC	CAP , CHIP	3300pF	1
C354	HCUS1H332KC	CAP , CHIP	3300pF	1
C355	HCUS1H332KC	CAP , CHIP	3300pF	1
C356	HCUS1H332KC	CAP , CHIP	3300pF	1
C357	HCUS1H332KC	CAP , CHIP	3300pF	1
C371	HCUS1H221JA	CAP , CHIP	220pF	1
C372	HCUS1H221JA	CAP , CHIP	220pF	1
C373	HCUS1H221JA	CAP , CHIP	220pF	1
C374	HCUS1H221JA	CAP , CHIP	220pF	1
C375	HCUS1H223KC	CAP , CHIP	0.022uF	1
C376	HCUS1H223KC	CAP , CHIP	0.022uF	1
C378	HCUS1H223KC	CAP , CHIP	0.022uF	1
C379	HCUS1H223KC	CAP , CHIP	0.022uF	1
C381	HCUS1H561JA	CAP , CHIP	560pF	1
C382	HCUS1H223KC	CAP , CHIP	0.022uF	1
C383	HCUS1H223KC	CAP , CHIP	0.022uF	1
C390	HCUS1H471JA	CAP , CHIP	470pF	1
C391	HCUS1H471JA	CAP , CHIP	470pF	1
C392	HCUS1H471JA	CAP , CHIP	470pF	1
C393	HCUS1H471JA	CAP , CHIP	470pF	1
C394	HCUS1H471JA	CAP , CHIP	470pF	1
C395	HCUS1H471JA	CAP , CHIP	470pF	1
C396	HCUS1H471JA	CAP , CHIP	470pF	1
C397	HCUS1H471JA	CAP , CHIP	470pF	1
C413	HCUS1H223KC	CAP , CHIP	0.022uF	1
C414	HCUS1H223KC	CAP , CHIP	0.022uF	1
C415	HCUS1H223KC	CAP , CHIP	0.022uF	1
C416	HCUS1H223KC	CAP , CHIP	0.022uF	1
C417	HCUS1H223KC	CAP , CHIP	0.022uF	1
C418	HCUS1H223KC	CAP , CHIP	0.022uF	1
C419	HCUS1H223KC	CAP , CHIP	0.022uF	1
C420	HCUS1H223KC	CAP , CHIP	0.022uF	1
C421	HCUS1H151JA	CAP , CHIP	150pF	1
C422	HCUS1H151JA	CAP , CHIP	150pF	1
C425	HCUS1H151JA	CAP , CHIP	150pF	1
C426	HCUS1H102KC	CAP , CHIP	1000pF	1
C427	HCUS1H151JA	CAP , CHIP	150pF	1
C428	HCUS1H151JA	CAP , CHIP	150pF	1
C429	HCUS1H151JA	CAP , CHIP	150pF	1
C430	HCUS1H151JA	CAP , CHIP	150pF	1
C471	HCUS1H181JA	CAP , CHIP	180pF	1
C472	HCUS1H181JA	CAP , CHIP	180pF	1
C473	HCUS1H181JA	CAP , CHIP	180pF	1
C474	HCUS1H181JA	CAP , CHIP	180pF	1
C701	HCUS1H330JA	CAP , CHIP	33pF	1
C702	HCUS1H330JA	CAP , CHIP	33pF	1
C704	HCUS1H104ZF	CAP , CHIP	0.1uF	1
C705	HCUS1H104ZF	CAP , CHIP	0.1uF	1
C707	HCUS1H102KC	CAP , CHIP	1000pF	1
C708	HCUS1H104ZF	CAP , CHIP	0.1uF	1
C718	HCUS1H104ZF	CAP , CHIP	0.1uF	1
C719	HCUS1H104ZF	CAP , CHIP	0.1uF	1
C722	HCUS1H104ZF	CAP , CHIP	0.1uF	1
C723	HCUS1H473ZF	CAP , CHIP	0.047uF	1
C725	HCUS1H104ZF	CAP , CHIP	0.1uF	1
C727	HCUS1H104ZF	CAP , CHIP	0.1uF	1
C729	HCUS1H104ZF	CAP , CHIP	0.1uF	1
C731	HCUS1H104ZF	CAP , CHIP	0.1uF	1

Ref. Designator	Part Number	Description		Qty
<b>INPUT PCB ASS'Y</b>				
C733	HCUS1H104ZF	CAP , CHIP	0.1uF	1
C734	HCUS1H122KC	CAP , CHIP	1200pF	1
C735	HCUS1H680JA	CAP , CHIP	68pF	1
C738	HCUS1C105ZF	CAP , CHIP	1UF 25V	1
C739	HCUS1H103KC	CAP , CHIP	0.1uF	1
C740	HCUS1H104ZF	CAP , CHIP	0.1uF	1
C742	HCUS1H104ZF	CAP , CHIP	0.1uF	1
C743	HCUS1H104ZF	CAP , CHIP	0.1uF	1
C744	HCUS1H104ZF	CAP , CHIP	0.1uF	1
C745	HCUS1H104ZF	CAP , CHIP	0.1uF	1
C747	HCUS1H104ZF	CAP , CHIP	0.1uF	1
C748	HCUS1H104ZF	CAP , CHIP	0.1uF	1
C750	HCUS1H104ZF	CAP , CHIP	0.1uF	1
C751	HCUS1H104ZF	CAP , CHIP	0.1uF	1
C752	HCUS1H104ZF	CAP , CHIP	0.1uF	1
C754	HCUS1H104ZF	CAP , CHIP	0.1uF	1
C756	HCUS1H104ZF	CAP , CHIP	0.1uF	1
C757	HCUS1H104ZF	CAP , CHIP	0.1uF	1
C758	HCUS1H104ZF	CAP , CHIP	0.1uF	1
C759	HCUS1H104ZF	CAP , CHIP	0.1uF	1
C760	HCUS1H104ZF	CAP , CHIP	0.1uF	1
C761	HCUS1H104ZF	CAP , CHIP	0.1uF	1
C762	HCUS1H104ZF	CAP , CHIP	0.1uF	1
C763	HCUS1H104ZF	CAP , CHIP	0.1uF	1
C765	HCUS1H104ZF	CAP , CHIP	0.1uF	1
C767	HCUS1H104ZF	CAP , CHIP	0.1uF	1
C768	HCUS1H104ZF	CAP , CHIP	0.1uF	1
C769	HCUS1H104ZF	CAP , CHIP	0.1uF	1
C770	HCUS1H104ZF	CAP , CHIP	0.1uF	1
C771	HCUS1H104ZF	CAP , CHIP	0.1uF	1
C772	HCUS1H104ZF	CAP , CHIP	0.1uF	1
C773	HCUS1H104ZF	CAP , CHIP	0.1uF	1
C103	CCEA1VH100T	CAP , ELECT	10UF 35V	1
C104	CCEA1VH100T	CAP , ELECT	10UF 35V	1
C237	CCEA1EH470T	CAP , ELECT	47UF 25V	1
C238	CCEA1EH470T	CAP , ELECT	47UF 25V	1
C239	CCEA1VH100T	CAP , ELECT	10UF 35V	1
C240	CCEA1VH100T	CAP , ELECT	10UF 35V	1
C251	CCEA1EH470T	CAP , ELECT	47UF 25V	1
C252	CCEA1EH470T	CAP , ELECT	47UF 25V	1
C261	CCEA1EH470T	CAP , ELECT	47UF 25V	1
C262	CCEA1EH470T	CAP , ELECT	47UF 25V	1
C263	CCEA1VH100T	CAP , ELECT	10UF 35V	1
C264	CCEA1VH100T	CAP , ELECT	10UF 35V	1
C265	CCEA1VH100T	CAP , ELECT	10UF 35V	1
C267	CCEA1VH100T	CAP , ELECT	10UF 35V	1
C268	CCEA1VH100T	CAP , ELECT	10UF 35V	1
C269	CCEA1VH100T	CAP , ELECT	10UF 35V	1
C341	CCEA1VH100T	CAP , ELECT	10UF 35V	1
C342	CCEA1VH100T	CAP , ELECT	10UF 35V	1
C343	CCEA1VH100T	CAP , ELECT	10UF 35V	1
C344	CCEA1VH100T	CAP , ELECT	10UF 35V	1
C345	CCEA1VH100T	CAP , ELECT	10UF 35V	1
C346	CCEA1VH100T	CAP , ELECT	10UF 35V	1
C347	CCEA1VH100T	CAP , ELECT	10UF 35V	1
C348	CCEA1VH100T	CAP , ELECT	10UF 35V	1
C349	CCEA1HH1R0T	CAP , ELECT	1UF 35V	1
C403	CCEA1VH100T	CAP , ELECT	10UF 35V	1

Ref. Designator	Part Number	Description		Qty
<b>INPUT PCB ASS'Y</b>				
C404	CCEA1VH100T	CAP , ELECT	10UF 35V	1
C405	CCEA1VH100T	CAP , ELECT	10UF 35V	1
C406	CCEA1VH100T	CAP , ELECT	10UF 35V	1
C407	CCEA1VH100T	CAP , ELECT	10UF 35V	1
C408	CCEA1VH100T	CAP , ELECT	10UF 35V	1
C409	CCEA1VH100T	CAP , ELECT	10UF 35V	1
C410	CCEA1VH100T	CAP , ELECT	10UF 35V	1
C433	CCEA1EH470T	CAP , ELECT	47UF 25V	1
C434	CCEA1EH470T	CAP , ELECT	47UF 25V	1
C435	CCEA1EH470T	CAP , ELECT	47UF 25V	1
C436	CCEA1EH470T	CAP , ELECT	47UF 25V	1
C437	CCEA1EH470T	CAP , ELECT	47UF 25V	1
C438	CCEA1EH470T	CAP , ELECT	47UF 25V	1
C439	CCEA1EH470T	CAP , ELECT	47UF 25V	1
C440	CCEA1EH470T	CAP , ELECT	47UF 25V	1
C453	CCEA1VH100T	CAP , ELECT	10UF 35V	1
C454	CCEA1VH100T	CAP , ELECT	10UF 35V	1
C455	CCEA1VH100T	CAP , ELECT	10UF 35V	1
C456	CCEA1VH100T	CAP , ELECT	10UF 35V	1
C457	CCEA1VH100T	CAP , ELECT	10UF 35V	1
C458	CCEA1VH100T	CAP , ELECT	10UF 35V	1
C459	CCEA1VH100T	CAP , ELECT	10UF 35V	1
C460	CCEA1VH100T	CAP , ELECT	10UF 35V	1
C703	CCEA1CH101T	CAP , ELECT	100UF 16V	1
C706	CCEA1CH101T	CAP , ELECT	100UF 16V	1
C717	CCEA1CH101T	CAP , ELECT	100UF 16V	1
C720	CCEA1AH471T	CAP , ELECT	470UF 10V	1
C721	CCEA1AH471T	CAP , ELECT	470UF 10V	1
C724	CCEA1AH471T	CAP , ELECT	470UF 10V	1
C726	CCEA1CH101T	CAP , ELECT	100UF 16V	1
C728	CCEA1AH471T	CAP , ELECT	470UF 10V	1
C730	CCEA1CH101T	CAP , ELECT	100UF 16V	1
C732	CCEA1CH101T	CAP , ELECT	100UF 16V	1
C736	CCEA1HH2R2T	CAP , ELECT	2.2UF 50V	1
C737	CCEA1CH101T	CAP , ELECT	100UF 16V	1
C741	CCEA1CH101T	CAP , ELECT	100UF 16V	1
C746	CCEA1CH101T	CAP , ELECT	100UF 16V	1
C749	CCEA1CH101T	CAP , ELECT	100UF 16V	1
C753	CCEA1CH101T	CAP , ELECT	100UF 16V	1
C755	CCEA1CH101T	CAP , ELECT	100UF 16V	1
C764	CCEA1AH471T	CAP , ELECT	470UF 10V	1
C766	CCEA0JH102T	CAP , ELECT	1000UF 6.3V	1
<b>Semiconductors</b>				
IC13	HVINJM2068MDTE1	I.C , OP AMP	JRC	1
IC23	HVITC9164CFG	I.C , FUNCTION SW	TOSHIBA	1
IC24	HVITC9163CFG	I.C , FUNCTION SW	TOSHIBA	1
IC25	HVINJM2068MDTE1	I.C , OP AMP	JRC	1
IC26	HVITC9162CFG	I.C , FUNCTION SW	TOSHIBA	1
IC31	HVINJM2068MDTE1	I.C , OP AMP	JRC NJM2068	1
IC32	HVINJM2068MDTE1	I.C , OP AMP	JRC NJM2068	1
IC33	HVINJM2068MDTE1	I.C , OP AMP	JRC NJM2068	1
IC34	HVINJM2068MDTE1	I.C , OP AMP	JRC NJM2068	1
IC35	HVINJM2068MDTE1	I.C , OP AMP	JRC NJM2068	1
IC36	HVINJM2068MDTE1	I.C , OP AMP	JRC NJM2068	1
IC37	HVINJM2068MDTE1	I.C , OP AMP	JRC NJM2068	1
IC42	HVITC9459BFG	I.C , 2CH VOLUME	TOSHIBA	1



Ref. Designator	Part Number	Description		Qty
<b>INPUT PCB ASS'Y</b>				
IC43	HVITC9482BFG	I.C , 6CH VOLUME	TOSHIBA	1
IC46	HVINJM2068MDTE1	I.C , OP AMP	JRC NJM2068	1
IC47	HVINJM2068MDTE1	I.C , OP AMP	JRC NJM2068	1
IC48	HVINJM2068MDTE1	I.C , OP AMP	JRC NJM2068	1
IC49	HVINJM2068MDTE1	I.C , OP AMP	JRC NJM2068	1
IC72	HVI74HCU04AFNG	I.C , INVERTER	TOSHIBA	1
IC73	HVIK4589VQ-T	I.C , CODEC + DIR	ASAHI KASEI	1
IC74	HVI74LCX32TTR	I.C , OR-GATE	FAIRCHILD	1
IC75	HVICS49400-CQ	I.C , DECODER	CIRRUS LOGIC	1
IC76	HVIM29W800DT70N	I.C, 4M FLASH MEMORY	ST	1
IC78	HVINJM2391DL133	I.C , CHIP REGULATOR (+3.3V)	JRC	1
IC79	HVINJM2391DL125	I.C , CHIP REGULATOR (+2.5V)	JRC	1
D201	HVD1SS133MT	DIODE	1SS133	1
D202	HVD1SS133MT	DIODE	1SS133	1
D203	HVD1SS133MT	DIODE	1SS133	1
D204	HVD1SS133MT	DIODE	1SS133	1
D207	HVD1SS133MT	DIODE	1SS133	1
D208	HVD1SS133MT	DIODE	1SS133	1
D209	HVD1SS133MT	DIODE	1SS133	1
D210	HVD1SS133MT	DIODE	1SS133	1
D211	HVD1SS133MT	DIODE	1SS133	1
D212	HVD1SS133MT	DIODE	1SS133	1
D213	HVD1SS133MT	DIODE	1SS133	1
D214	HVD1SS133MT	DIODE	1SS133	1
D215	HVD1SS133MT	DIODE	1SS133	1
D216	HVD1SS133MT	DIODE	1SS133	1
D701	KVD1N4003ST	DIODE	1N4003	1
Q201	HVTKTC2874BT	TRANSISTOR , MUTE	KTC2874B	1
Q202	HVTKTC2874BT	TRANSISTOR , MUTE	KTC2874B	1
Q203	HVTKTC2874BT	TRANSISTOR , MUTE	KTC2874B	1
Q204	HVTKRA107MT	TRANSISTOR	KRA107M	1
<i>Resistors</i>				
RN80	CRJ104DJ330T	RES , 4ARRAY (1608*4)	33 OHM/1608*4	1
RN81	CRJ104DJ330T	RES , 4ARRAY (1608*4)	33 OHM/1608*4	1
RN82	CRJ104DJ330T	RES , 4ARRAY (1608*4)	33 OHM/1608*4	1
RN83	CRJ104DJ330T	RES , 4ARRAY (1608*4)	33 OHM/1608*4	1
RN84	CRJ104DJ332T	RES, ARRAY, 3.3K*4 (1608)	3.3K OHM/1608*4	1
RN86	CRJ104DJ103T	RES, ARRAY, 10K (1608)	10K OHM/1608*4	1
RN87	CRJ104DJ103T	RES, ARRAY, 10K (1608)	10K OHM/1608*4	1
RN88	CRJ104DJ103T	RES, ARRAY, 10K (1608)	10K OHM/1608*4	1
RN89	CRJ104DJ103T	RES, ARRAY, 10K (1608)	10K OHM/1608*4	1
RN90	CRJ104DJ103T	RES, ARRAY, 10K (1608)	10K OHM/1608*4	1
R101	CRJ10DJ562T	RES , CHIP	5.6K OHM	1
R102	CRJ10DJ562T	RES , CHIP	5.6K OHM	1
R103	CRJ10DJ682T	RES , CHIP	6.8K OHM	1
R104	CRJ10DJ682T	RES , CHIP	6.8K OHM	1
R105	CRJ10DJ151T	RES, CHIP	150 OHM	1
R106	CRJ10DJ151T	RES, CHIP	150 OHM	1
R107	CRJ10DJ101T	RES , CHIP	100 OHM	1
R108	CRJ10DJ101T	RES , CHIP	100 OHM	1
R201	CRJ10DJ471T	RES , CHIP	470 OHM	1
R202	CRJ10DJ471T	RES , CHIP	470 OHM	1
R203	CRJ10DJ471T	RES , CHIP	470 OHM	1
R204	CRJ10DJ471T	RES , CHIP	470 OHM	1
R205	CRJ10DJ471T	RES , CHIP	470 OHM	1
R206	CRJ10DJ471T	RES , CHIP	470 OHM	1

Ref. Designator	Part Number	Description		Qty
<b>INPUT PCB ASS'Y</b>				
R211	CRJ10DJ471T	RES , CHIP	470 OHM	1
R212	CRJ10DJ471T	RES , CHIP	470 OHM	1
R213	CRJ10DJ471T	RES , CHIP	470 OHM	1
R214	CRJ10DJ471T	RES , CHIP	470 OHM	1
R215	CRJ10DJ471T	RES , CHIP	470 OHM	1
R216	CRJ10DJ471T	RES , CHIP	470 OHM	1
R217	CRJ10DJ471T	RES , CHIP	470 OHM	1
R218	CRJ10DJ471T	RES , CHIP	470 OHM	1
R219	CRJ10DJ471T	RES , CHIP	470 OHM	1
R220	CRJ10DJ471T	RES , CHIP	470 OHM	1
R221	CRJ10DJ471T	RES , CHIP	470 OHM	1
R222	CRJ10DJ471T	RES , CHIP	470 OHM	1
R223	CRJ10DJ471T	RES , CHIP	470 OHM	1
R224	CRJ10DJ272T	RES , CHIP	2.7K OHM	1
R225	CRJ10DJ471T	RES , CHIP	470 OHM	1
R226	CRJ10DJ471T	RES , CHIP	470 OHM	1
R227	CRJ10DJ474T	RES , CHIP	470K OHM	1
R228	CRJ10DJ474T	RES , CHIP	470K OHM	1
R229	CRJ10DJ474T	RES , CHIP	470K OHM	1
R230	CRJ10DJ474T	RES , CHIP	470K OHM	1
R231	CRJ10DJ474T	RES , CHIP	470K OHM	1
R232	CRJ10DJ474T	RES , CHIP	470K OHM	1
R237	CRJ10DJ474T	RES , CHIP	470K OHM	1
R238	CRJ10DJ474T	RES , CHIP	470K OHM	1
R239	CRJ10DJ474T	RES , CHIP	470K OHM	1
R240	CRJ10DJ474T	RES , CHIP	470K OHM	1
R241	CRJ10DJ474T	RES , CHIP	470K OHM	1
R242	CRJ10DJ474T	RES , CHIP	470K OHM	1
R243	CRJ10DJ474T	RES , CHIP	470K OHM	1
R244	CRJ10DJ474T	RES , CHIP	470K OHM	1
R245	CRJ10DJ474T	RES , CHIP	470K OHM	1
R246	CRJ10DJ474T	RES , CHIP	470K OHM	1
R247	CRJ10DJ474T	RES , CHIP	470K OHM	1
R248	CRJ10DJ474T	RES , CHIP	470K OHM	1
R249	CRJ10DJ474T	RES , CHIP	470K OHM	1
R250	CRJ10DJ103T	RES , CHIP	10K OHM	1
R251	CRJ10DJ474T	RES , CHIP	470K OHM	1
R252	CRJ10DJ474T	RES , CHIP	470K OHM	1
R265	CRJ10DJ471T	RES , CHIP	470 OHM	1
R267	CRJ10DJ471T	RES , CHIP	470 OHM	1
R268	CRJ10DJ184T	RES , CHIP	180K OHM	1
R269	CRJ10DJ184T	RES , CHIP	180K OHM	1
R270	CRJ10DJ472T	RES , CHIP	4.7K OHM	1
R271	CRJ10DJ472T	RES , CHIP	4.7K OHM	1
R272	CRJ10DJ472T	RES , CHIP	4.7K OHM	1
R273	CRJ10DJ471T	RES , CHIP	470 OHM	1
R274	CRJ10DJ471T	RES , CHIP	470 OHM	1
R275	CRJ10DJ472T	RES , CHIP	4.7K OHM	1
R276	CRJ10DJ472T	RES , CHIP	4.7K OHM	1
R277	CRJ10DJ472T	RES , CHIP	4.7K OHM	1
R278	CRJ10DJ104T	RES , CHIP	100K OHM	1
R279	CRJ10DJ104T	RES , CHIP	100K OHM	1
R283	CRJ10DJ331T	RES , CHIP	330 OHM	1
R284	CRJ10DJ331T	RES , CHIP	330 OHM	1
R285	CRJ10DJ184T	RES , CHIP	180K OHM	1
R286	CRJ10DJ184T	RES , CHIP	180K OHM	1
R287	CRJ10DJ184T	RES , CHIP	180K OHM	1
R288	CRJ10DJ184T	RES , CHIP	180K OHM	1

Ref. Designator	Part Number	Description		Qty
<b>INPUT PCB ASS'Y</b>				
R289	CRJ10DJ184T	RES , CHIP	180K OHM	1
R290	CRJ10DJ184T	RES , CHIP	180K OHM	1
R291	CRJ10DJ472T	RES , CHIP	4.7K OHM	1
R292	CRJ10DJ472T	RES , CHIP	4.7K OHM	1
R293	CRJ10DJ472T	RES , CHIP	4.7K OHM	1
R301	CRJ10DJ332T	RES , CHIP	3.3K OHM	1
R302	CRJ10DJ332T	RES , CHIP	3.3K OHM	1
R303	CRJ10DJ332T	RES , CHIP	3.3K OHM	1
R304	CRJ10DJ332T	RES , CHIP	3.3K OHM	1
R305	CRJ10DJ332T	RES , CHIP	3.3K OHM	1
R306	CRJ10DJ332T	RES , CHIP	3.3K OHM	1
R307	CRJ10DJ332T	RES , CHIP	3.3K OHM	1
R308	CRJ10DJ332T	RES , CHIP	3.3K OHM	1
R309	CRJ10DJ332T	RES , CHIP	3.3K OHM	1
R310	CRJ10DJ332T	RES , CHIP	3.3K OHM	1
R311	CRJ10DJ332T	RES , CHIP	3.3K OHM	1
R312	CRJ10DJ332T	RES , CHIP	3.3K OHM	1
R313	CRJ10DJ332T	RES , CHIP	3.3K OHM	1
R314	CRJ10DJ332T	RES , CHIP	3.3K OHM	1
R315	CRJ10DJ332T	RES , CHIP	3.3K OHM	1
R316	CRJ10DJ332T	RES , CHIP	3.3K OHM	1
R317	CRJ10DJ101T	RES , CHIP	100 OHM	1
R318	CRJ10DJ101T	RES , CHIP	100 OHM	1
R319	CRJ10DJ101T	RES , CHIP	100 OHM	1
R320	CRJ10DJ101T	RES , CHIP	100 OHM	1
R321	CRJ10DJ512T	RES , CHIP	5.1 OHM	1
R322	CRJ10DJ122T	RES , CHIP	1.2K OHM	1
R323	CRJ10DJ122T	RES , CHIP	1.2K OHM	1
R324	CRJ10DJ512T	RES , CHIP	5.1 OHM	1
R325	CRJ10DJ512T	RES , CHIP	5.1 OHM	1
R326	CRJ10DJ122T	RES , CHIP	1.2K OHM	1
R327	CRJ10DJ122T	RES , CHIP	1.2K OHM	1
R328	CRJ10DJ123T	RES , CHIP	12K OHM	1
R329	CRJ10DJ512T	RES , CHIP	5.1 OHM	1
R330	CRJ10DJ122T	RES , CHIP	1.2K OHM	1
R331	CRJ10DJ122T	RES , CHIP	1.2K OHM	1
R332	CRJ10DJ512T	RES , CHIP	5.1 OHM	1
R333	CRJ10DJ512T	RES , CHIP	5.1 OHM	1
R334	CRJ10DJ122T	RES , CHIP	1.2K OHM	1
R335	CRJ10DJ122T	RES , CHIP	1.2K OHM	1
R336	CRJ10DJ512T	RES , CHIP	5.1 OHM	1
R337	CRJ10DJ101T	RES , CHIP	100 OHM	1
R338	CRJ10DJ101T	RES , CHIP	100 OHM	1
R339	CRJ10DJ101T	RES , CHIP	100 OHM	1
R340	CRJ10DJ101T	RES , CHIP	100 OHM	1
R341	CRJ10DJ122T	RES , CHIP	1.2K OHM	1
R344	CRJ10DJ122T	RES , CHIP	1.2K OHM	1
R345	CRJ10DJ122T	RES , CHIP	1.2K OHM	1
R348	CRJ10DJ122T	RES , CHIP	1.2K OHM	1
R349	CRJ10DJ122T	RES , CHIP	1.2K OHM	1
R352	CRJ10DJ122T	RES , CHIP	1.2K OHM	1
R353	CRJ10DJ122T	RES , CHIP	1.2K OHM	1
R356	CRJ10DJ122T	RES , CHIP	1.2K OHM	1
R361	CRJ10DJ104T	RES , CHIP	100K OHM	1
R362	CRJ10DJ104T	RES , CHIP	100K OHM	1
R363	CRJ10DJ104T	RES , CHIP	100K OHM	1
R364	CRJ10DJ104T	RES , CHIP	100K OHM	1
R365	CRJ10DJ104T	RES , CHIP	100K OHM	1

Ref. Designator	Part Number	Description		Qty
<b>INPUT PCB ASS'Y</b>				
R366	CRJ10DJ104T	RES , CHIP	100K OHM	1
R367	CRJ10DJ104T	RES , CHIP	100K OHM	1
R368	CRJ10DJ104T	RES , CHIP	100K OHM	1
R371	CRJ10DJ332T	RES , CHIP	3.3K OHM	1
R372	CRJ10DJ332T	RES , CHIP	3.3K OHM	1
R373	CRJ10DJ332T	RES , CHIP	3.3K OHM	1
R374	CRJ10DJ332T	RES , CHIP	3.3K OHM	1
R375	CRJ10DJ332T	RES , CHIP	3.3K OHM	1
R376	CRJ10DJ332T	RES , CHIP	3.3K OHM	1
R377	CRJ10DJ332T	RES , CHIP	3.3K OHM	1
R378	CRJ10DJ332T	RES , CHIP	3.3K OHM	1
R379	CRJ10DJ332T	RES , CHIP	3.3K OHM	1
R380	CRJ10DJ332T	RES , CHIP	3.3K OHM	1
R381	CRJ10DJ101T	RES , CHIP	100 OHM	1
R382	CRJ10DJ101T	RES , CHIP	100 OHM	1
R383	CRJ10DJ101T	RES , CHIP	100 OHM	1
R384	CRJ10DJ101T	RES , CHIP	100 OHM	1
R385	CRJ10DJ101T	RES , CHIP	100 OHM	1
R386	CRJ10DJ101T	RES , CHIP	100 OHM	1
R389	CRJ10DJ332T	RES , CHIP	3.3K OHM	1
R390	CRJ10DJ332T	RES , CHIP	3.3K OHM	1
R391	CRJ10DJ105T	RES , CHIP	1M OHM	1
R392	CRJ10DJ105T	RES , CHIP	1M OHM	1
R393	CRJ10DJ332T	RES , CHIP	3.3K OHM	1
R394	CRJ10DJ153T	RES , CHIP	15K OHM	1
R395	CRJ10DJ153T	RES , CHIP	15K OHM	1
R396	CRJ10DJ332T	RES , CHIP	3.3K OHM	1
R397	CRJ10DJ101T	RES , CHIP	100 OHM	1
R398	CRJ10DJ101T	RES , CHIP	100 OHM	1
R403	CRJ10DJ184T	RES , CHIP	180K OHM	1
R404	CRJ10DJ184T	RES , CHIP	180K OHM	1
R405	CRJ10DJ184T	RES , CHIP	180K OHM	1
R406	CRJ10DJ184T	RES , CHIP	180K OHM	1
R407	CRJ10DJ184T	RES , CHIP	180K OHM	1
R408	CRJ10DJ184T	RES , CHIP	180K OHM	1
R409	CRJ10DJ184T	RES , CHIP	180K OHM	1
R410	CRJ10DJ184T	RES , CHIP	180K OHM	1
R413	CRJ10DJ512T	RES , CHIP	5.1 OHM	1
R414	CRJ10DJ512T	RES , CHIP	5.1 OHM	1
R415	CRJ10DJ512T	RES , CHIP	5.1 OHM	1
R416	CRJ10DJ912T	RES,CHIP(1/10W) 9.1K OHM J	9.1K OHM	1
R417	CRJ10DJ512T	RES , CHIP	5.1 OHM	1
R418	CRJ10DJ512T	RES , CHIP	5.1 OHM	1
R419	CRJ10DJ512T	RES , CHIP	5.1 OHM	1
R420	CRJ10DJ512T	RES , CHIP	5.1 OHM	1
R423	CRJ10DJ102T	RES , CHIP	1K OHM	1
R424	CRJ10DJ102T	RES , CHIP	1K OHM	1
R425	CRJ10DJ102T	RES , CHIP	1K OHM	1
R426	CRJ10DJ102T	RES , CHIP	1K OHM	1
R427	CRJ10DJ102T	RES , CHIP	1K OHM	1
R428	CRJ10DJ102T	RES , CHIP	1K OHM	1
R429	CRJ10DJ102T	RES , CHIP	1K OHM	1
R430	CRJ10DJ102T	RES , CHIP	1K OHM	1
R433	CRJ10DJ101T	RES , CHIP	100 OHM	1
R434	CRJ10DJ101T	RES , CHIP	100 OHM	1
R435	CRJ10DJ101T	RES , CHIP	100 OHM	1
R436	CRJ10DJ101T	RES , CHIP	100 OHM	1
R437	CRJ10DJ101T	RES , CHIP	100 OHM	1

Ref. Designator	Part Number	Description		Qty
<b>INPUT PCB ASS'Y</b>				
R438	CRJ10DJ101T	RES , CHIP	100 OHM	1
R439	CRJ10DJ101T	RES , CHIP	100 OHM	1
R440	CRJ10DJ101T	RES , CHIP	100 OHM	1
R453	CRJ10DJ184T	RES , CHIP	180K OHM	1
R454	CRJ10DJ184T	RES , CHIP	180K OHM	1
R455	CRJ10DJ184T	RES , CHIP	180K OHM	1
R456	CRJ10DJ184T	RES , CHIP	180K OHM	1
R457	CRJ10DJ184T	RES , CHIP	180K OHM	1
R458	CRJ10DJ184T	RES , CHIP	180K OHM	1
R459	CRJ10DJ184T	RES , CHIP	180K OHM	1
R460	CRJ10DJ184T	RES , CHIP	180K OHM	1
R471	CRJ10DJ272T	RES , CHIP	2.7K OHM	1
R472	CRJ10DJ272T	RES , CHIP	2.7K OHM	1
R473	CRJ10DJ272T	RES , CHIP	2.7K OHM	1
R474	CRJ10DJ272T	RES , CHIP	2.7K OHM	1
R481	CRJ10DJ512T	RES , CHIP	5.1 OHM	1
R482	CRJ10DJ512T	RES , CHIP	5.1 OHM	1
R483	CRJ10DJ512T	RES , CHIP	5.1 OHM	1
R484	CRJ10DJ123T	RES , CHIP	12K OHM	1
R485	CRJ10DJ512T	RES , CHIP	5.1 OHM	1
R486	CRJ10DJ512T	RES , CHIP	5.1 OHM	1
R487	CRJ10DJ512T	RES , CHIP	5.1 OHM	1
R488	CRJ10DJ512T	RES , CHIP	5.1 OHM	1
R491	CRJ10DJ4R7T	RES , CHIP	4.7 OHM	1
R492	CRJ10DJ4R7T	RES , CHIP	4.7 OHM	1
R494	CRJ10DJ4R7T	RES , CHIP	4.7 OHM	1
R495	CRJ10DJ4R7T	RES , CHIP	4.7 OHM	1
R496	CRJ10DJ4R7T	RES , CHIP	4.7 OHM	1
R497	CRJ10DJ4R7T	RES , CHIP	4.7 OHM	1
R498	CRJ10DJ4R7T	RES , CHIP	4.7 OHM	1
R701	CRJ10DJ0R0T	RES , CHIP	0 OHM	1
R702	CRJ10DJ101T	RES , CHIP	100 OHM	1
R703	CRJ10DJ101T	RES , CHIP	100 OHM	1
R704	CRJ10DJ101T	RES , CHIP	100 OHM	1
R705	CRJ10DJ102T	RES , CHIP	1K OHM	1
R707	CRJ10DJ101T	RES , CHIP	100 OHM	1
R714	CRJ10DJ104T	RES , CHIP	100K OHM	1
R715	CRJ10DJ104T	RES , CHIP	100K OHM	1
R716	CRJ10DJ472T	RES , CHIP	4.7K OHM	1
R717	CRJ10DJ3R3T	RES , CHIP	3.3 OHM	1
R718	CRJ10DJ123T	RES , CHIP	12K OHM	1
R719	CRJ10DJ473T	RES , CHIP	47K OHM	1
R720	CRJ10DJ473T	RES , CHIP	47K OHM	1
R721	CRJ10DJ330T	RES , CHIP	33 OHM	1
R723	CRJ10DJ2R7T	RES , CHIP	2.7 OHM	1
R724	CRJ10DJ101T	RES , CHIP	100 OHM	1
R725	CRJ10DJ473T	RES , CHIP	47K OHM	1
R726	CRJ10DJ473T	RES , CHIP	47K OHM	1
R727	CRJ10DJ473T	RES , CHIP	47K OHM	1
R728	CRJ10DJ330T	RES , CHIP	33 OHM	1
R759	CRJ10DJ181T	RES , CHIP	180 OHM	1
R760	CRJ10DJ105T	RES , CHIP	1M OHM	1
R765	CRJ10DJ103T	RES , CHIP	10K OHM	1
R766	CRJ10DJ103T	RES , CHIP	10K OHM	1
R767	CRJ10DJ152T	RES , CHIP	1.5K OHM	1
R768	CRJ10DJ152T	RES , CHIP	1.5K OHM	1
R769	CRJ10DJ103T	RES , CHIP	10K OHM	1
R770	CRJ10DJ103T	RES , CHIP	10K OHM	1

Ref. Designator	Part Number	Description		Qty
<b>INPUT PCB ASS'Y</b>				
R771	CRJ10DJ330T	RES , CHIP	33 OHM	1
R772	CRJ10DJ330T	RES , CHIP	33 OHM	1
R773	CRJ10DJ103T	RES , CHIP	10K OHM	1
R774	CRJ10DJ330T	RES , CHIP	33 OHM	1
R775	CRJ10DJ103T	RES , CHIP	10K OHM	1
R776	CRJ10DJ332T	RES , CHIP	3.3K OHM	1
R777	CRJ10DJ102T	RES , CHIP	1K OHM	1
R778	CRJ10DJ103T	RES , CHIP	10K OHM	1
R779	CRJ10DJ103T	RES , CHIP	10K OHM	1
R786	CRJ10DJ103T	RES , CHIP	10K OHM	1
R787	CRJ10DJ332T	RES , CHIP	3.3K OHM	1
R788	CRJ10DJ332T	RES , CHIP	3.3K OHM	1
R801	CRJ10DJ103T	RES , CHIP	10K OHM	1
R802	CRJ10DJ103T	RES , CHIP	10K OHM	1
R803	CRJ10DJ330T	RES , CHIP	33 OHM	1
R804	CRJ10DJ103T	RES , CHIP	10K OHM	1
R809	CRJ10DJ330T	RES , CHIP	33 OHM	1
R810	CRJ10DJ330T	RES , CHIP	33 OHM	1
R814	CRJ10DJ101T	RES , CHIP	100 OHM	1
R815	CRJ10DJ103T	RES , CHIP	10K OHM	1
R817	CRJ10DJ103T	RES , CHIP	10K OHM	1
R821	CRJ10DJ103T	RES , CHIP	10K OHM	1
R823	CRJ10DJ101T	RES , CHIP	100 OHM	1
R780	CRG2ANJ470H	RES , METAL OXIDE FILM	47 OHM 2W J	1
R781	CRG2ANJ470H	RES , METAL OXIDE FILM	47 OHM 2W J	1
R782	CRG2ANJ330H	RES , METAL OXIDE FILM	33 OHM 2W J	1
<i>Miscellaneous</i>				
L701	HLZ9Z014Z	CHIP , BEAD	HU-1H4516-600JT	1
L702	HLZ9Z014Z	CHIP , BEAD	HU-1H4516-600JT	1
L703	HLZ9Z014Z	CHIP , BEAD	HU-1H4516-600JT	1
L704	HLZ9Z014Z	CHIP , BEAD	HU-1H4516-600JT	1
BN11	KJP08GB99ZM	CONNECTOR , HOUSING	CONNECTOR	1
BN12	KJP15GB99ZM	WAFER	WAFER	1
BN42	CWZAVR140BN42	WIRE ASS'Y	WIRE	1
CN10	CJP04GB46ZY	WAFER	WAFER	1
CN13	CJP13GA115ZY	WAFER , CARD CABLE	WAFER	1
CN15	CJP13GA115ZY	WAFER , CARD CABLE	WAFER	1
CN17	KJP12GB142ZP	PIN HEADER	PIN HEADER	1
CN18	CJP05GA19ZY	WAFER , STRAIGHT, 5PIN	WAFER	1
CN72	KJP32GA117ZG	WAFER , CARD CABLE	WAFER	1
CN97	CJP02GA19ZY	WAFER, 2PIN	WAFER	1
JK11	CJJ4R019W	TERMINAL , IN/OUT	TERMINAL JACK	1
JK13	CJJ4P014W	JACK , IN/OUT	JACK	1
JK14	CJJ4R019W	TERMINAL , IN/OUT	TERMINAL JACK	1
JK15	CJJ4R037W	JACK , BOARD	JACK	1
JW21	CWE7202090AA	WIRE ASS'Y	WIRE	1
X701	HOX12288E220CS	CRYSTAL	12.288MHZ 22PF	1
<b>MAIN/VIDEO/BIAS/DIGITAL PCB ASS'Y SECTION 1</b>				
<i>Capacitors</i>				
C107	CCKT1H103ZF	CAP , CERAMIC	0.01UF 50V ZF	1
C108	CCKT1H103ZF	CAP , CERAMIC	0.01UF 50V ZF	1
C109	CCFT1H104ZF	CAP , SEMICONDUCTOR	0.1UF 50V ZF	1
C110	CCFT1H104ZF	CAP , SEMICONDUCTOR	0.1UF 50V ZF	1

Ref. Designator	Part Number	Description		Qty
<b>MAIN/VIDEO/BIAS/DIGITAL PCB ASS'Y SECTION 1</b>				
C111	CCKT1H103ZF	CAP , CERAMIC	0.01UF 50V ZF	1
C112	CCKT1H103ZF	CAP , CERAMIC	0.01UF 50V ZF	1
C117	CCEA1HH4R7T	CAP , ELECT	4.7UF 50V	1
C118	CCKT1H103ZF	CAP , CERAMIC	0.01UF 50V ZF	1
C119	CCEA1JH470TS	CAP , ELECT	63V/47UF/105°C	1
C120	CCEA1JH470TS	CAP , ELECT	63V/47UF/105°C	1
C121	CCKT1H103ZF	CAP , CERAMIC	0.01UF 50V ZF	1
C403	CCEA1VH100T	CAP , ELECT	10UF 35V	1
C404	CCKT1H101KB	CAP , CERAMIC	100PF 50V KB	1
C405	CCEA1VH100T	CAP , ELECT	10UF 35V	1
C406	CCEA1VH100T	CAP , ELECT	10UF 35V	1
C407	CCKT1H101KB	CAP , CERAMIC	100PF 50V KB	1
C411	HCBS1H101KBT	CAP , CERAMIC	100PF 50V K	1
C412	HCBS1H101KBT	CAP , CERAMIC	100PF 50V K	1
C413	HCBS1H101KBT	CAP , CERAMIC	100PF 50V K	1
C414	HCBS1H101KBT	CAP , CERAMIC	100PF 50V K	1
C416	CCEA1CH101T	CAP , ELECT	100UF 16V	1
C417	CCEA1CH101T	CAP , ELECT	100UF 16V	1
C418	HCBS1H223ZFT	CAP , CERAMIC	0.022UF 50V Z	1
C419	CCEA1VH100T	CAP , ELECT	10UF 35V	1
C420	HCBS1H223ZFT	CAP , CERAMIC	0.022UF 50V Z	1
C421	CCEA1CH101T	CAP , ELECT	100UF 16V	1
C422	HCBS1H223ZFT	CAP , CERAMIC	0.022UF 50V Z	1
C423	CCEA1CH101T	CAP , ELECT	100UF 16V	1
C424	CCEA1VH100T	CAP , ELECT	10UF 35V	1
C425	CCEA1VH100T	CAP , ELECT	10UF 35V	1
C426	CCEA1VH100T	CAP , ELECT	10UF 35V	1
C427	HCBS1H223ZFT	CAP , CERAMIC	0.022UF 50V Z	1
C428	CCEA1CH101T	CAP , ELECT	100UF 16V	1
C429	HCBS1H223ZFT	CAP , CERAMIC	0.022UF 50V Z	1
C430	CCEA1CH101T	CAP , ELECT	100UF 16V	1
C431	CCEA1VH100T	CAP , ELECT	10UF 35V	1
C432	CCEA1VH100T	CAP , ELECT	10UF 35V	1
C436	HCBS1H223ZFT	CAP , CERAMIC	0.022UF 50V Z	1
C437	CCEA1CH101T	CAP , ELECT	100UF 16V	1
C438	HCBS1H223ZFT	CAP , CERAMIC	0.022UF 50V Z	1
C439	CCEA1CH101T	CAP , ELECT	100UF 16V	1
C442	HCBS1H103ZFT	CAP , CERAMIC	0.01UF 50V Z	1
C443	CCEA1VH100T	CAP , ELECT	10UF 35V	1
C444	CCEA1VH100T	CAP , ELECT	10UF 35V	1
C445	HCBS1H103ZFT	CAP , CERAMIC	0.01UF 50V Z	1
C446	CCEA1VH100T	CAP , ELECT	10UF 35V	1
C447	CCEA1VH100T	CAP , ELECT	10UF 35V	1
C448	HCBS1H223ZFT	CAP , CERAMIC	0.022UF 50V Z	1
C449	CCEA1CH101T	CAP , ELECT	100UF 16V	1
C450	HCBS1H223ZFT	CAP , CERAMIC	0.022UF 50V Z	1
C451	CCEA1CH101T	CAP , ELECT	100UF 16V	1
C452	HCBS1H223ZFT	CAP , CERAMIC	0.022UF 50V Z	1
C453	CCEA1CH101T	CAP , ELECT	100UF 16V	1
C454	HCBS1H223ZFT	CAP , CERAMIC	0.022UF 50V Z	1
C455	CCEA1CH101T	CAP , ELECT	100UF 16V	1
C456	HCBS1H104ZFT	CAP , CERAMIC	0.1UF 50V Z	1
C457	CCEA1CH101T	CAP , ELECT	100UF 16V	1
C458	CCEA1CH101T	CAP , ELECT	100UF 16V	1
C459	HCBS1H104ZFT	CAP , CERAMIC	0.1UF 50V Z	1
C460	HCBS1C272MXT	CAP , CERAMIC	2700PF 16V	1
C461	CCEA1CH101T	CAP , ELECT	100UF 16V	1
C462	CCEA1CH101T	CAP , ELECT	100UF 16V	1



Ref. Designator	Part Number	Description		Qty
<b>MAIN/VIDEO/BIAS/DIGITAL PCB ASS'Y SECTION 1</b>				
C463	HCBS1H473ZFT	CAP , CERAMIC	0.047UF 50V Z	1
C501	HCBS1H330JT	CAP , CERAMIC	33PF 50V	1
C502	HCBS1H330JT	CAP , CERAMIC	33PF 50V	1
C503	HCBS1H181KBT	CAP , CERAMIC	180PF 50V K	1
C504	CCEA1HHR47T	CAP , ELECT	0.47UF 50V	1
C505	HCBS1H223ZFT	CAP , CERAMIC	0.022UF 50V Z	1
C506	CCEA1AH471T	CAP , ELECT	470UF 10V	1
C507	CCCT1H220JC	CAP , CERAMIC	22PF 50V	1
C508	CCCT1H270JC	CAP , CERAMIC	27PF 50V	1
C509	CCEA1HH1R0T	CAP , ELECT	1UF 50V	1
C510	CCEA1HH1R0T	CAP , ELECT	1UF 50V	1
C511	HCQI1H682JZT	CAP , MYLAR	6800PF 50V J	1
C512	CCEA1HH1R0T	CAP , ELECT	1UF 50V	1
C513	HCBS1H560JT	CAP , CERAMIC	56PF 50V J	1
C514	HCBS1H220JCT	CAP , CERAMIC	22PF 50V J	1
C515	CCEA1AH471T	CAP , ELECT	470UF 10V	1
C517	HCBS1H223ZFT	CAP , CERAMIC	0.022UF 50V Z	1
C518	HCBS1H223ZFT	CAP , CERAMIC	0.022UF 50V Z	1
C519	CCFT1H104ZF	CAP , SEMICONDUCTOR	0.1UF 50V ZF	1
C523		WIRE , COPPER	SN95/PB5 , 0.6	1
C555	CCEA1AH471T	CAP , ELECT	470UF 10V	1
C556	CCEA1CH101T	CAP , ELECT	100UF 16V	1
C557	CCEA1CH101T	CAP , ELECT	100UF 16V	1
C561	CCEA1CH101T	CAP , ELECT	100UF 16V	1
C568	HCBS1H104ZFT	CAP , CERAMIC	0.1UF 50V Z	1
C601	HCBS1H220JCT	CAP , CERAMIC	22PF 50V J	1
C602	HCBS1H220JCT	CAP , CERAMIC	22PF 50V J	1
C603	HCBS1H220JCT	CAP , CERAMIC	22PF 50V J	1
C604	HCBS1H220JCT	CAP , CERAMIC	22PF 50V J	1
C605	HCBS1H220JCT	CAP , CERAMIC	22PF 50V J	1
C606	HCBS1H220JCT	CAP , CERAMIC	22PF 50V J	1
C607	HCBS1H220JCT	CAP , CERAMIC	22PF 50V J	1
C608	HCBS1H220JCT	CAP , CERAMIC	22PF 50V J	1
C609	HCBS1H220JCT	CAP , CERAMIC	22PF 50V J	1
C610	HCBS1H223ZFT	CAP , CERAMIC	0.022UF 50V Z	1
C611	CCEA1CH101T	CAP , ELECT	100UF 16V	1
C612	HCBS1H223ZFT	CAP , CERAMIC	0.022UF 50V Z	1
C613	CCEA1CH101T	CAP , ELECT	100UF 16V	1
C701	CCEA1AH471T	CAP , ELECT	470UF 10V	1
C702	CCEA1AH471T	CAP , ELECT	470UF 10V	1
C703	CCKT1H181KB	CAP , CERAMIC	180PF 50V KB	1
C704	CCFT1H104ZF	CAP , SEMICONDUCTOR	0.1UF 50V ZF	1
C705	CCKT1H181KB	CAP , CERAMIC	180PF 50V KB	1
C706	CCFT1H104ZF	CAP , SEMICONDUCTOR	0.1UF 50V ZF	1
C707	CCKT1H101KB	CAP , CERAMIC	100PF 50V KB	1
C708	CCEA1CH101T	CAP , ELECT	100UF 16V	1
C709	HCBS1H104ZFT	CAP , CERAMIC	0.1UF 50V Z	1
C711	CCEA1CH101T	CAP , ELECT	100UF 16V	1
C712	HCBS1H473ZFT	CAP , CERAMIC	0.047UF 50V Z	1
C852	CCEA1HH100T	CAP , ELECT	10UF 50V	1
C853	CCEA1HH100T	CAP , ELECT	10UF 50V	1
C854	CCEA1HH100T	CAP , ELECT	10UF 50V	1
C855	CCEA1HH100T	CAP , ELECT	10UF 50V	1
C856	CCEA1HH100T	CAP , ELECT	10UF 50V	1
C857	CCEA1HH100T	CAP , ELECT	10UF 50V	1
C921	HCQI1H104JZT	CAP , MYLAR	0.1UF 50V J	1
C922	HCQI1H104JZT	CAP , MYLAR	0.1UF 50V J	1
C923	HCQI1H104JZT	CAP , MYLAR	0.1UF 50V J	1

Ref. Designator	Part Number	Description		Qty
<b>MAIN/VIDEO/BIAS/DIGITAL PCB ASS'Y SECTION 1</b>				
C924	HCQI1H104JZT	CAP , MYLAR	0.1UF 50V J	1
C925	HCQI1H103JZT	CAP , MYLAR	0.01UF 50V J	1
C926	HCQI1H103JZT	CAP , MYLAR	0.01UF 50V J	1
C927	HCQI1H103JZT	CAP , MYLAR	0.01UF 50V J	1
C928	HCQI1H103JZT	CAP , MYLAR	0.01UF 50V J	1
C931	HCQI1H473JZT	CAP , MYLAR	0.047UF 50V J	1
C932	HCQI1H473JZT	CAP , MYLAR	0.047UF 50V J	1
C933	HCQI1H473JZT	CAP , MYLAR	0.047UF 50V J	1
C934	HCQI1H473JZT	CAP , MYLAR	0.047UF 50V J	1
C935	CCKT1H223ZF	CAP , CERAMIC	0.022UF 50V ZF	1
C936	CCKT1H223ZF	CAP , CERAMIC	0.022UF 50V ZF	1
C937	CCKT1H223ZF	CAP , CERAMIC	0.022UF 50V ZF	1
C938	CCEA1EH101T	CAP , ELECT	100UF 25V	1
C939	CCEA1EH101T	CAP , ELECT	100UF 25V	1
C940	CCEA1EH101T	CAP , ELECT	100UF 25V	1
C942	CCEA1HH2R2T	CAP , ELECT	2.2UF 50V	1
C122	CCEA2AH101E	CAP , ELECT	100UF	1
C124	HCQE2E104KDE	CAP , LINE ACROSS	0.1UF	1
C520	CCEA0JKR3222E	CAP , ELECT	2200UF 6.3V	1
C929	CCEA1VH332F	CAP , ELECT (ANGLE)	3300UF 35V	1
C930	CCEA1VH222F	CAP , ELECT (ANGLE)	2200UF 35V	1
C941	CCEA1CKR3103E	CAP , ELECT	10000UF , 16V	1
<i>Semiconductors</i>				
D101	HVDMTZJ15BT	DIODE , ZENER	15V 1/2W	1
D102	HVDMTZJ27BT	DIODE , ZENER	27V 1/2W	1
D104	HVD1N5819T	DIODE , SCHOTTKY	1N5819	1
D105	HVD1N5819T	DIODE , SCHOTTKY	1N5819	1
D108	KVD1N4003ST	DIODE	1N4003	1
D109	HVDMTZJ12BT	DIODE , ZENER	12V 1/2W	1
D111	HVDMTZJ12BT	DIODE , ZENER	12V 1/2W	1
D401	HVD1SS133MT	DIODE	1SS133	1
D402	HVD1SS133MT	DIODE	1SS133	1
D403	HVD1SS133MT	DIODE	1SS133	1
D404	HVD1SS133MT	DIODE	1SS133	1
D405	HVD1SS133MT	DIODE	1SS133	1
D904	KVD1N4003ST	DIODE	1N4003	1
D905	KVD1N4003ST	DIODE	1N4003	1
D906	KVD1N4003ST	DIODE	1N4003	1
D907	KVD1N4003ST	DIODE	1N4003	1
D915	HVD1SS133MT	DIODE	1SS133	1
D916	HVD1SS133MT	DIODE	1SS133	1
D917	HVDSB2100	DIODE , SCHOTTKY	SB2100	1
D918	HVDSB2100	DIODE , SCHOTTKY	SB2100	1
Q104	HVTKSC2316YT	TRANSISTOR	KSC2316Y	1
Q402	HVTKSA733CYT	TRANSISTOR	KSA733CY	1
Q403	HVTKRA107MT	TRANSISTOR	KRA107M	1
Q404	HVTKRC107MT	TRANSISTOR	KRC107M	1
Q405	HVTKSA733CYT	TRANSISTOR	KSA733CY	1
Q406	HVTKRA107MT	TRANSISTOR	KRA107M	1
Q407	HVTKRC107MT	TRANSISTOR	KRC107M	1
Q408	HVTKRC107MT	TRANSISTOR	KRC107M	1
Q409	HVTKRA104MT	TRANSISTOR	KRA104M	1
Q410	HVTKTD1302T	TRANSISTOR	KTD1302	1
Q411	HVTKTD1302T	TRANSISTOR	KTD1302	1
Q412	HVTKRA104MT	TRANSISTOR	KRA104M	1
Q501	HVTKSC2785YT	TRANSISTOR	KSC2785Y(DEAD)	1

Ref. Designator	Part Number	Description		Qty
<b>MAIN/VIDEO/BIAS/DIGITAL PCB ASS'Y SECTION 1</b>				
Q502	HVTKSA1175YT	TRANSISTOR	KSA1175Y(DEAD)	1
Q556	HVTKSA1175YT	TRANSISTOR	KSA1175Y(DEAD)	1
Q568	HVTKTC2874BT	TRANSISTOR , MUTE	KTC2874B	1
Q569	HVTKRC107MT	TRANSISTOR	KRC107M	1
IC41	HVINJM2296M	I.C , VIDEO SW	JRC	1
IC42	HVINJM2296M	I.C , VIDEO SW	JRC	1
IC43	HVINJM2296M	I.C , VIDEO SW	JRC	1
IC44	HVIHCF4053M013T	I.C	ST	1
IC45	HVIHCF4053M013T	I.C	ST	1
IC46	HVINJM2581MTE1	I.C	JRC	1
IC47	HVIMM1511XNRE	IC, Y/C-MIX	MITSUMI	1
IC48	CVIL7805CPNA	I.C ASS'Y	ASS'Y	1
IC49	CVIL7905CPNA	I.C ASS'Y	ASS'Y	1
D991	CVDKBU804FMA	BRIDGE DIODE ASS'Y	ASS'Y	1
D992	CVDKBU804FMA	BRIDGE DIODE ASS'Y	ASS'Y	1
	HVDKBU804F	DIODE , BRIDGE	BRIDGE DIODE	1
IC51	HVILC74763M	I.C , OSD	SANYO	1
IC52	HVI74ACT04MTR	I.C , HEX	ST	1
IC61	HVINJM2586AMTE1	I.C , VIDEO SW	JRC	1
IC71	HVI74HCU04AFNG	I.C , INVERTER	TOSHIBA	1
IC91	HVIL7815CP	I.C, REGULATOR	ST	1
IC92	HVIL7915CP	I.C, REGULATOR	ST	1
IC93	HVIL7805CP	I.C, REGULATOR	ST	1
Q852	HVTKTD600KGR	TRANSISTOR , BIAS	KTD600KGR	1
Q853	HVTKTD600KGR	TRANSISTOR , BIAS	KTD600KGR	1
Q854	HVTKTD600KGR	TRANSISTOR , BIAS	KTD600KGR	1
Q855	HVTKTD600KGR	TRANSISTOR , BIAS	KTD600KGR	1
Q856	HVTKTD600KGR	TRANSISTOR , BIAS	KTD600KGR	1
Q857	HVTKTD600KGR	TRANSISTOR , BIAS	KTD600KGR	1
	HVIL7905CP	I.C, REGULATOR	ST	1
	HVIL7805CP	I.C, REGULATOR	ST	1
<i>Resistors</i>				
R101	KRD25FJ3R3T	RES , CARBON	3.3 OHM 1/4W J	1
R108	CRD20TJ4R7T	RES , CARBON	4.7 OHM 1/5W	1
R109	CRD20TJ100T	RES , CARBON	10 OHM 1/5W J	1
R110	CRD20TJ4R7T	RES , CARBON	4.7 OHM 1/5W	1
R112	CRD20TJ122T	RES , CARBON	1.2K OHM 1/5W J	1
R113	CRD20TJ473T	RES , CARBON	47K OHM 1/5W J	1
R404	CRD20TJ750T	RES , CARBON	75 OHM 1/5W J	1
R405	CRD20TJ750T	RES , CARBON	75 OHM 1/5W J	1
R406	CRD20TJ332T	RES , CARBON	3.3K OHM 1/5W J	1
R407	CRD20TJ750T	RES , CARBON	75 OHM 1/5W J	1
R408	CRD20TJ750T	RES , CARBON	75 OHM 1/5W J	1
R409	CRD20TJ750T	RES , CARBON	75 OHM 1/5W J	1
R410	CRD20TJ332T	RES , CARBON	3.3K OHM 1/5W J	1
R417	CRD20TJ750T	RES , CARBON	75 OHM 1/5W J	1
R418	CRD20TJ750T	RES , CARBON	75 OHM 1/5W J	1
R419	CRD20TJ750T	RES , CARBON	75 OHM 1/5W J	1
R420	CRD20TJ332T	RES , CARBON	3.3K OHM 1/5W J	1
R421	CRD20TJ750T	RES , CARBON	75 OHM 1/5W J	1
R422	CRD20TJ332T	RES , CARBON	3.3K OHM 1/5W J	1
R423	CRD20TJ750T	RES , CARBON	75 OHM 1/5W J	1
R424	CRD20TJ750T	RES , CARBON	75 OHM 1/5W J	1
R425	CRD20TJ750T	RES , CARBON	75 OHM 1/5W J	1
R426	CRD20TJ332T	RES , CARBON	3.3K OHM 1/5W J	1
R427	CRD20TJ750T	RES , CARBON	75 OHM 1/5W J	1

Ref. Designator	Part Number	Description		Qty
<b>MAIN/VIDEO/BIAS/DIGITAL PCB ASS'Y SECTION 1</b>				
R428	CRD20TJ332T	RES , CARBON	3.3K OHM 1/5W J	1
R430	CRD20TJ1R8T	RES , CARBON	1.8 OHM 1/5W J	1
R431	CRD20TJ102T	RES , CARBON	1K OHM 1/5W J	1
R432	CRD20TJ1R0T	RES , CARBON	1 OHM 1/5W J	1
R433	CRD20TJ102T	RES , CARBON	1K OHM 1/5W J	1
R434	CRD20TJ102T	RES , CARBON	1K OHM 1/5W J	1
R435	CRD20TJ102T	RES , CARBON	1K OHM 1/5W J	1
R436	CRD20TJ102T	RES , CARBON	1K OHM 1/5W J	1
R437	CRD20TJ102T	RES , CARBON	1K OHM 1/5W J	1
R438	CRD25TJ1R0T	RES , CARBON	1 OHM 1/4W J	1
R439	CRD20TJ750T	RES , CARBON	75 OHM 1/5W J	1
R440	CRD20TJ1R8T	RES , CARBON	1.8 OHM 1/5W J	1
R441	CRD20TJ102T	RES , CARBON	1K OHM 1/5W J	1
R442	CRD20TJ102T	RES , CARBON	1K OHM 1/5W J	1
R443	CRD20TJ102T	RES , CARBON	1K OHM 1/5W J	1
R444	CRD20TJ102T	RES , CARBON	1K OHM 1/5W J	1
R445	CRD20TJ1R0T	RES , CARBON	1 OHM 1/5W J	1
R446	CRD20TJ102T	RES , CARBON	1K OHM 1/5W J	1
R447	CRD20TJ750T	RES , CARBON	75 OHM 1/5W J	1
R448	CRD20TJ1R8T	RES , CARBON	1.8 OHM 1/5W J	1
R449	CRD20TJ102T	RES , CARBON	1K OHM 1/5W J	1
R450	CRD20TJ102T	RES , CARBON	1K OHM 1/5W J	1
R451	CRD20TJ102T	RES , CARBON	1K OHM 1/5W J	1
R452	CRD20TJ102T	RES , CARBON	1K OHM 1/5W J	1
R453	CRD20TJ332T	RES , CARBON	3.3K OHM 1/5W J	1
R454	CRD20TJ562T	RES , CARBON	5.6K OHM 1/5W J	1
R455	CRD20TJ105T	RES , CARBON	1M OHM 1/5W J	1
R456	CRD20TJ680T	RES , CARBON	68 OHM 1/5W J	1
R457	CRD20TJ333T	RES , CARBON	33K OHM 1/5W J	1
R458	CRD20TJ123T	RES , CARBON	12K OHM 1/5W J	1
R459	CRD20TJ680T	RES , CARBON	68 OHM 1/5W J	1
R460	CRD20TJ333T	RES , CARBON	33K OHM 1/5W J	1
R461	CRD20TJ123T	RES , CARBON	12K OHM 1/5W J	1
R462	CRD20TJ102T	RES , CARBON	1K OHM 1/5W J	1
R463	CRD20TJ103T	RES , CARBON	10K OHM 1/5W J	1
R464	CRD20TJ103T	RES , CARBON	10K OHM 1/5W J	1
R465	CRD20TJ103T	RES , CARBON	10K OHM 1/5W J	1
R466	CRD20TJ103T	RES , CARBON	10K OHM 1/5W J	1
R467	CRD20TJ103T	RES , CARBON	10K OHM 1/5W J	1
R468	CRD20TJ100T	RES , CARBON	10 OHM 1/5W J	1
R469	CRD20TJ100T	RES , CARBON	10 OHM 1/5W J	1
R470	CRD20TJ100T	RES , CARBON	10 OHM 1/5W J	1
R471	CRD20TJ100T	RES , CARBON	10 OHM 1/5W J	1
R472	CRD20TJ151T	RES , CARBON	150 OHM 1/5W J	1
R473	CRD20TJ181T	RES , CARBON	180 OHM 1/5W J	1
R474	CRD20TJ1R8T	RES , CARBON	1.8 OHM 1/5W J	1
R475	CRD20TJ1R0T	RES , CARBON	1 OHM 1/5W J	1
R476	CRD25TJ101T	RES , CARBON	100 OHM 1/4W J	1
R477	CRD20TJ2R2T	RES , CARBON	2.2 OHM 1/5W J	1
R478	CRD20TJ223T	RES , CARBON	22K OHM 1/5W J	1
R479	CRD20TJ181T	RES , CARBON	180 OHM 1/5W J	1
R480	CRD20TJ223T	RES , CARBON	22K OHM 1/5W J	1
R481	CRD20TJ183T	RES , CARBON	18K OHM 1/5W J	1
R484	CRD20TJ104T	RES , CARBON	100K OHM 1/5W J	1
R485	CRD20TJ103T	RES , CARBON	10K OHM 1/5W J	1
R501	CRD20TJ102T	RES , CARBON	1K OHM 1/5W J	1
R502	CRD20TJ102T	RES , CARBON	1K OHM 1/5W J	1
R503	CRD20TJ102T	RES , CARBON	1K OHM 1/5W J	1

Ref. Designator	Part Number	Description		Qty
<b>MAIN/VIDEO/BIAS/DIGITAL PCB ASS'Y SECTION 1</b>				
R504	CRD20TJ104T	RES , CARBON	100K OHM 1/5W J	1
R505	CRD20TJ102T	RES , CARBON	1K OHM 1/5W J	1
R506	CRD20TJ102T	RES , CARBON	1K OHM 1/5W J	1
R507	CRD20TJ102T	RES , CARBON	1K OHM 1/5W J	1
R508	CRD20TJ682T	RES , CARBON	6.8K OHM 1/5W J	1
R509	CRD20TJ152T	RES , CARBON	1.5K OHM 1/5W J	1
R510	CRD20TJ393T	RES , CARBON	39K OHM 1/5W J	1
R511	CRD20TJ222T	RES , CARBON	2.2K OHM 1/5W J	1
R512	CRD20TJ102T	RES , CARBON	1K OHM 1/5W J	1
R513	CRD20TJ822T	RES , CARBON	8.2K OHM 1/5W J	1
R514	CRD20TJ103T	RES , CARBON	10K OHM 1/5W J	1
R516	CRD20TJ202T	RES , CARBON	2K OHM 1/5W J	1
R517	CRD20TJ273T	RES , CARBON	27K OHM 1/5W J	1
R555	CRD20TJ101T	RES , CARBON	100 OHM 1/5W J	1
R556	CRD20TJ183T	RES , CARBON	18K OHM 1/5W J	1
R558	CRD20TJ102T	RES , CARBON	1K OHM 1/5W J	1
R568	CRD20TJ223T	RES , CARBON	22K OHM 1/5W J	1
R569	CRD20TJ223T	RES , CARBON	22K OHM 1/5W J	1
R601	CRD20TJ750T	RES , CARBON	75 OHM 1/5W J	1
R602	CRD20TJ750T	RES , CARBON	75 OHM 1/5W J	1
R603	CRD20TJ750T	RES , CARBON	75 OHM 1/5W J	1
R604	CRD20TJ750T	RES , CARBON	75 OHM 1/5W J	1
R605	CRD20TJ750T	RES , CARBON	75 OHM 1/5W J	1
R606	CRD20TJ750T	RES , CARBON	75 OHM 1/5W J	1
R607	CRD20TJ750T	RES , CARBON	75 OHM 1/5W J	1
R608	CRD20TJ750T	RES , CARBON	75 OHM 1/5W J	1
R609	CRD20TJ750T	RES , CARBON	75 OHM 1/5W J	1
R610	CRD20TJ4R7T	RES , CARBON	4.7 OHM 1/5W J	1
R611	CRD20TJ4R7T	RES , CARBON	4.7 OHM 1/5W J	1
R612	CRD20TJ472T	RES , CARBON	4.7K OHM 1/5W J	1
R701	CRD20TJ103T	RES , CARBON	10K OHM 1/5W J	1
R702	CRD20TJ1R0T	RES , CARBON	1 OHM 1/5W J	1
R703	CRD20TJ103T	RES , CARBON	10K OHM 1/5W J	1
R704	CRD20TJ1R0T	RES , CARBON	1 OHM 1/5W J	1
R705	CRD20TJ750T	RES , CARBON	75 OHM 1/5W J	1
R706	CRD20TJ750T	RES , CARBON	75 OHM 1/5W J	1
R707	CRD20TJ100T	RES , CARBON	10 OHM 1/5W J	1
R708	CRD20TJ241T	RES , CARBON	240OHM 1/5W J	1
R709	CRD20TJ750T	RES , CARBON	75 OHM 1/5W J	1
R710	CRD20TJ1R0T	RES , CARBON	1 OHM 1/5W J	1
R711	CRD20TJ1R0T	RES , CARBON	1 OHM 1/5W J	1
R713	CRD20TJ104T	RES , CARBON	100K OHM 1/5W J	1
R714	CRD20TJ104T	RES , CARBON	100K OHM 1/5W J	1
R715	CRD20TJ102T	RES , CARBON	1K OHM 1/5W J	1
R716	CRD20TJ102T	RES , CARBON	1K OHM 1/5W J	1
R717	CRD20TJ472T	RES , CARBON	4.7K OHM 1/5W J	1
R718	CRD20TJ472T	RES , CARBON	4.7K OHM 1/5W J	1
R719	CRD20TJ102T	RES , CARBON	1K OHM 1/5W J	1
R720	CRD20TJ102T	RES , CARBON	1K OHM 1/5W J	1
R875	CRD20TJ331T	RES , CARBON	330 OHM 1/5W J	1
R876	CRD20TJ331T	RES , CARBON	330 OHM 1/5W J	1
R877	CRD20TJ331T	RES , CARBON	330 OHM 1/5W J	1
R878	CRD20TJ331T	RES , CARBON	330 OHM 1/5W J	1
R879	CRD20TJ331T	RES , CARBON	330 OHM 1/5W J	1
R880	CRD20TJ331T	RES , CARBON	330 OHM 1/5W J	1
R883	CRD20TJ122T	RES , CARBON	1.2K OHM 1/5W J	1
R884	CRD20TJ122T	RES , CARBON	1.2K OHM 1/5W J	1
R885	CRD20TJ122T	RES , CARBON	1.2K OHM 1/5W J	1

Ref. Designator	Part Number	Description		Qty
<b>MAIN/VIDEO/BIAS/DIGITAL PCB ASS'Y SECTION 1</b>				
R886	CRD20TJ122T	RES , CARBON	1.2K OHM 1/5W J	1
R887	CRD20TJ122T	RES , CARBON	1.2K OHM 1/5W J	1
R888	CRD20TJ122T	RES , CARBON	1.2K OHM 1/5W J	1
R912	CRD20TJ153T	RES , CARBON	15K OHM 1/5W J	1
R913	CRD20TJ153T	RES , CARBON	15K OHM 1/5W J	1
R914	CRD20TJ103T	RES , CARBON	10K OHM 1/5W J	1
VR82	HVN1RA221B01T	RES , SEMI FIXED	220 OHM	1
VR83	HVN1RA221B01T	RES , SEMI FIXED	220 OHM	1
VR84	HVN1RA221B01T	RES , SEMI FIXED	220 OHM	1
VR85	HVN1RA221B01T	RES , SEMI FIXED	220 OHM	1
VR86	HVN1RA221B01T	RES , SEMI FIXED	220 OHM	1
VR87	HVN1RA221B01T	RES , SEMI FIXED	220 OHM	1
R104	KRQ1AJR47H	RES , FUSE	0.47 OHM 1W J	1
R105	KRQ1AJR47H	RES , FUSE	0.47 OHM 1W J	1
R106	CRQ1AJR33H	RES , FUSE	0.33 OHM 1W J	1
R107	CRQ1AJR33H	RES , FUSE	0.33 OHM 1W J	1
<i>Miscellaneous</i>				
JK42	CJJ9N001Z	JACK , S-VIDEO (2P/H)	S-VIDEO JACK	1
JK43	CJJ9S001Z	JACK , S-VIDEO (3P/H)	S-VIDEO JACK	1
JK49	CJJ4N043Z	JACK , BOARD	JACK	1
JK50	CJJ4S010Z	JACK , BOARD	JACK	1
JK61	CJJ4L009Z	JACK 9P (RRR/BBB/GGG)	JACK	1
JK71	HJSTORX177L	MODULE , OPTICAL(RX)	OPTICAL JACK	1
JK72	HJSTORX177L	MODULE , OPTICAL(RX)	OPTICAL JACK	1
JK73	CJJ4S022Z	JACK , BOARD	JACK	1
JK74	HJSTOTX177L	MODULE , OPTICAL(TX)	OPTICAL JACK	1
JW11	CWEP202110VV	WIRE	WIRE	1
OL91	KJJ7A015Z	OUTLET , AC(UL/2P/SEP)	OUTLET	1
SW91	KST1A010Z	SW , TACT CN	SWITCH	1
X501	HOX14318E220C	CRYSTAL	14.318Mhz	1
<b>IPOD PCB ASS'Y</b>				
<i>Capacitors</i>				
C400	HCUS1H104ZF	CAP , CHIP	0.1UF	1
C401	HCUS1H104ZF	CAP , CHIP	0.1UF	1
C402	HCUS1H471JA	CAP , CHIP	470PF	1
C403	HCUS1H471JA	CAP , CHIP	470PF	1
C408	HCEC1CRV2100T	CAP , ELEC (SMD)	10UF / 16V	1
C409	HCEC1CRV2100T	CAP , ELEC (SMD)	10UF / 16V	1
C410	HCEC1CRV2100T	CAP , ELEC (SMD)	10UF / 16V	1
C411	HCEC1CRV2100T	CAP , ELEC (SMD)	10UF / 16V	1
C416	HCUS1H473ZF	CAP , CHIP	0.047UF	1
C421	HCUS1H471JA	CAP , CHIP	470PF	1
C422	HCUS1H471JA	CAP , CHIP	470PF	1
C423	HCUS1H223KC	CAP , CHIP	0.022UF	1
C424	HCUS1H223KC	CAP , CHIP	0.022UF	1
C417	CCEA1CH471T	CAP , ELECT	470UF 16V	1
<i>Semiconductors</i>				
D402	KVD1N4003ST	DIODE	1N4003	1
D400	HVD1SS355T	DIODE , CHIP	1SS355	1
D401	HVD1SS355T	DIODE , CHIP	1SS355	1

Ref. Designator	Part Number	Description		Qty
<b>IPOD PCB ASS'Y</b>				
IC41	HVITC9215AF	I.C	TOSHIBA	1
Q400	HVTKRC102S	TRANSISTOR , CHIP	KRC102S	1
Q402	HVTKRC102S	TRANSISTOR , CHIP	KRC102S	1
<i>Resistors</i>				
R400	CRJ10DJ4R7T	RES , CHIP	4.7 OHM	1
R401	CRJ10DJ4R7T	RES , CHIP	4.7 OHM	1
R402	CRJ10DF5493T	RES , CHIP	549KOHM/1608/1%	1
R403	CRJ10DJ0R0T	RES , CHIP	O HOM	1
R404	CRJ10DJ470T	RES , CHIP	47 OHM	1
R405	CRJ10DJ470T	RES , CHIP	47 OHM	1
R406	CRJ10DJ474T	RES , CHIP	470K OHM	1
R407	CRJ10DJ474T	RES , CHIP	470K OHM	1
R412	CRJ10DJ471T	RES , CHIP	470 OHM	1
R413	CRJ10DJ471T	RES , CHIP	470 OHM	1
R419	CRJ10DJ332T	RES , CHIP	3.3K OHM 1/5W J	1
R421	CRJ10DJ223T	RES , CHIP	22K OHM 1/5W J	1
R422	CRJ10DJ224T	RES , CHIP	220K OHM	1
<i>Miscellaneous</i>				
CN42	CJP05GB46ZY	WAFER	WAFER	1
CN44	CJP04GB46ZY	WAFER	WAFER	1
JK40	HJJ9L003Z	JACK , IPOD	IPOD JACK	1
ET01	CMD1A570	BRACKET , PCB	BRACKET	1
R416	CLZ9Z068Z	COIL,CHOKE	CHOKE COIL	1
	CHG1A306	CUSHION	CUSHION	1
<b>MAIN/VIDEO/BIAS/DIGITAL PCB ASS'Y SECTION 2</b>				
<i>Capacitors</i>				
C501	CCEA1VH100T	CAP , ELECT	10UF 35V	1
C502	CCEA1VH100T	CAP , ELECT	10UF 35V	1
C503	CCEA1VH100T	CAP , ELECT	10UF 35V	1
C504	CCEA1VH100T	CAP , ELECT	10UF 35V	1
C505	CCEA1VH100T	CAP , ELECT	10UF 35V	1
C506	CCKT1H331KB	CAP , CERAMIC	330PF 50V KB	1
C507	CCKT1H331KB	CAP , CERAMIC	330PF 50V KB	1
C508	CCKT1H331KB	CAP , CERAMIC	330PF 50V KB	1
C509	CCKT1H331KB	CAP , CERAMIC	330PF 50V KB	1
C510	CCKT1H331KB	CAP , CERAMIC	330PF 50V KB	1
C561	HCEA1CH101T	CAP , ELECT	100UF 16V	1
C562	HCEA1CH101T	CAP , ELECT	100UF 16V	1
C564	HCEA1CH101T	CAP , ELECT	100UF 16V	1
C566	HCEA1CH101T	CAP , ELECT	100UF 16V	1
C567	HCEA1CH101T	CAP , ELECT	100UF 16V	1
C568	HCEA1CH101T	CAP , ELECT	100UF 16V	1
C569	HCEA1CH101T	CAP , ELECT	100UF 16V	1
C570	HCEA1CH101T	CAP , ELECT	100UF 16V	1
C571	HCBS1H681KBT	CAP , CERAMIC	680PF	1
C572	HCBS1H681KBT	CAP , CERAMIC	680PF	1
C573	HCBS1H681KBT	CAP , CERAMIC	680PF	1
C574	HCBS1H681KBT	CAP , CERAMIC	680PF	1
C575	HCBS1H681KBT	CAP , CERAMIC	680PF	1
C601	CCCT1H120JC	CAP , CERAMIC	12PF 50V JC	1
C602	CCCT1H120JC	CAP , CERAMIC	12PF 50V JC	1



Ref. Designator	Part Number	Description		Qty
<b>MAIN/VIDEO/BIAS/DIGITAL PCB ASS'Y SECTION 2</b>				
C603	CCCT1H120JC	CAP , CERAMIC	12PF 50V JC	1
C604	CCCT1H120JC	CAP , CERAMIC	12PF 50V JC	1
C605	CCCT1H120JC	CAP , CERAMIC	12PF 50V JC	1
C606	CCCT1H330JC	CAP , CERAMIC	33PF 50V JC	1
C607	CCCT1H330JC	CAP , CERAMIC	33PF 50V JC	1
C608	CCCT1H330JC	CAP , CERAMIC	33PF 50V JC	1
C609	CCCT1H330JC	CAP , CERAMIC	33PF 50V JC	1
C610	CCCT1H330JC	CAP , CERAMIC	33PF 50V JC	1
C681	HCEA1HH100T	CAP , ELECT	10UF 50V	1
C682	HCEA1HH100T	CAP , ELECT	10UF 50V	1
C683	HCEA1HH100T	CAP , ELECT	10UF 50V	1
C684	HCEA1HH100T	CAP , ELECT	10UF 50V	1
C685	HCEA1HH100T	CAP , ELECT	10UF 50V	1
C726	CCKT1H221KB	CAP , CERAMIC	220PF 50V KB	1
C801	HCEA1HH100T	CAP , ELECT	10UF 50V	1
C803	CCCT1H330JC	CAP , CERAMIC	33PF 50V JC	1
C805	CCCT1H120JC	CAP , CERAMIC	12PF 50V JC	1
C811	HCEA1CH101T	CAP , ELECT	100UF 16V	1
C813	HCEA1CH101T	CAP , ELECT	100UF 16V	1
C815	CCKT1H331KB	CAP , CERAMIC	330PF 50V KB	1
C817	CCEA1VH100T	CAP , ELECT	10UF 35V	1
C819	HCBS1H681KBT	CAP , CERAMIC	680PF	1
C900	HCQI1H473JZT	CAP , MYLAR	0.047UF 50V J	1
C901	HCQI1H473JZT	CAP , MYLAR	0.047UF 50V J	1
C905	CCKT1H223ZF	CAP , CERAMIC	0.022UF 50V ZF	1
C907	HCEA1CH101T	CAP , ELECT	100UF 16V	1
C908	CCKT1H223ZF	CAP , CERAMIC	0.022UF 50V ZF	1
C910	HCQI1H473JZT	CAP , MYLAR	0.047UF 50V J	1
C911	CCEA1CH471T	CAP , ELECT	470UF 16V	1
C912	CCEA1EH221T	CAP , ELECT	220UF 25V	1
C913	CCFT1H104ZF	CAP , SEMICONDUCTOR	0.1UF 50V ZF	1
C917	HCQI1H473JZT	CAP , MYLAR	0.047UF 50V J	1
C918	HCQI1H473JZT	CAP , MYLAR	0.047UF 50V J	1
C919	HCQI1H473JZT	CAP , MYLAR	0.047UF 50V J	1
C939	CCEA1HH4R7T	CAP , ELECT	4.7UF 50V	1
C940	CCEA1AH471T	CAP , ELECT	470UF 10V	1
C971	HCQI1H562JZT	CAP , MYLAR	5600PF 50V J	1
C973	HCQI1H562JZT	CAP , MYLAR	5600PF 50V J	1
C974	HCQI1H562JZT	CAP , MYLAR	5600PF 50V J	1
C975	HCQI1H562JZT	CAP , MYLAR	5600PF 50V J	1
C980	HCQI1H562JZT	CAP , MYLAR	5600PF 50V J	1
C981	HCQI1H562JZT	CAP , MYLAR	5600PF 50V J	1
C990	HCQI1H473JZT	CAP , MYLAR	0.047UF 50V J	1
C991	CCEA1HH1R0T	CAP , ELECT	1UF 50V	1
C992	HCQI1H473JZT	CAP , MYLAR	0.047UF 50V J	1
C993	HCQI1H473JZT	CAP , MYLAR	0.047UF 50V J	1
C995	HCQI1H473JZT	CAP , MYLAR	0.047UF 50V J	1
C996	HCQI1H473JZT	CAP , MYLAR	0.047UF 50V J	1
C997	HCQI1H473JZT	CAP , MYLAR	0.047UF 50V J	1
C999	CCKT1H223ZF	CAP , CERAMIC	0.022UF 50V ZF	1
C563	HCEA1CH101T	CAP , ELECT	100UF 16V	1
C565	HCEA1CH101T	CAP , ELECT	100UF 16V	1
C631	CCEA1JH101E	CAP , ELECT	100UF 63V	1
C632	CCEA1JH101E	CAP , ELECT	100UF 63V	1
C633	CCEA1JH101E	CAP , ELECT	100UF 63V	1
C634	CCEA1JH101E	CAP , ELECT	100UF 63V	1
C635	CCEA1JH101E	CAP , ELECT	100UF 63V	1
C636	CCEA1JH101E	CAP , ELECT	100UF 63V	1

Ref. Designator	Part Number	Description		Qty
<b>MAIN/VIDEO/BIAS/DIGITAL PCB ASS'Y SECTION 2</b>				
C637	CCEA1JH101E	CAP , ELECT	100UF 63V	1
C638	CCEA1JH101E	CAP , ELECT	100UF 63V	1
C639	CCEA1JH101E	CAP , ELECT	100UF 63V	1
C640	CCEA1JH101E	CAP , ELECT	100UF 63V	1
C807	CCEA1JH101E	CAP , ELECT	100UF 63V	1
C808	CCEA1JH101E	CAP , ELECT	100UF 63V	1
C902	CCET50VKL4822NK	CAP , ELECT	8200UF/50V	1
C904	KCKDKS472ME	CAP , CERAMIC(X1/Y2/SC)	0.0047UF/2.5KV	1
C906	CCEA1EH102E	CAP , ELECT	1000UF 25V	1
C909	CCET50VKL4822NK	CAP , ELECT	8200UF/50V	1
C915	CCET50VKL4822NK	CAP , ELECT	8200UF/50V	1
C916	CCET50VKL4822NK	CAP , ELECT	8200UF/50V	1
<i>Semiconductors</i>				
D501	HVD1SS133MT	DIODE	1SS133	1
D502	HVD1SS133MT	DIODE	1SS133	1
D503	HVD1SS133MT	DIODE	1SS133	1
D504	HVD1SS133MT	DIODE	1SS133	1
D505	HVD1SS133MT	DIODE	1SS133	1
D581	HVD1SS133MT	DIODE	1SS133	1
D582	HVD1SS133MT	DIODE	1SS133	1
D583	HVD1SS133MT	DIODE	1SS133	1
D584	HVD1SS133MT	DIODE	1SS133	1
D585	HVD1SS133MT	DIODE	1SS133	1
D801	HVD1SS133MT	DIODE	1SS133	1
D803	HVD1SS133MT	DIODE	1SS133	1
D901	KVD1N4003ST	DIODE	1N4003	1
D902	HVD1SS133MT	DIODE	1SS133	1
D911	HVD1SS133MT	DIODE	1SS133	1
D912	HVD1SS133MT	DIODE	1SS133	1
D914	HVD1SS133MT	DIODE	1SS133	1
D917	HVD1SS133MT	DIODE	1SS133	1
D953	HVD1SS133MT	DIODE	1SS133	1
D954	KVD1N4003SRT	DIODE TW	1N4003	1
D955	KVD1N4003SRT	DIODE TW	1N4003	1
D961	KVD1N4003ST	DIODE	1N4003	1
D962	KVD1N4003ST	DIODE	1N4003	1
D963	KVD1N4003ST	DIODE	1N4003	1
D977	HVD1SS133MT	DIODE	1SS133	1
D978	HVD1SS133MT	DIODE	1SS133	1
Q501	HVTKTA1268GRT	TRANSISTOR	KTA1268GR	1
Q502	HVTKTA1268GRT	TRANSISTOR	KTA1268GR	1
Q503	HVTKTA1268GRT	TRANSISTOR	KTA1268GR	1
Q504	HVTKTA1268GRT	TRANSISTOR	KTA1268GR	1
Q505	HVTKTA1268GRT	TRANSISTOR	KTA1268GR	1
Q511	HVTKTC3200GRT	TRANSISTOR	KTC3200GR	1
Q512	HVTKTC3200GRT	TRANSISTOR	KTC3200GR	1
Q513	HVTKTC3200GRT	TRANSISTOR	KTC3200GR	1
Q514	HVTKTC3200GRT	TRANSISTOR	KTC3200GR	1
Q515	HVTKTC3200GRT	TRANSISTOR	KTC3200GR	1
Q516	HVTKTC3200GRT	TRANSISTOR	KTC3200GR	1
Q517	HVTKTC3200GRT	TRANSISTOR	KTC3200GR	1
Q518	HVTKTC3200GRT	TRANSISTOR	KTC3200GR	1
Q519	HVTKTC3200GRT	TRANSISTOR	KTC3200GR	1
Q520	HVTKTC3200GRT	TRANSISTOR	KTC3200GR	1
Q541	HVTKTC3198YT	TRANSISTOR	KTC3198Y	1
Q542	HVTKTC3198YT	TRANSISTOR	KTC3198Y	1

Ref. Designator	Part Number	Description		Qty
<b>MAIN/VIDEO/BIAS/DIGITAL PCB ASS'Y SECTION 2</b>				
Q543	HVTKTC3198YT	TRANSISTOR	KTC3198Y	1
Q544	HVTKTC3198YT	TRANSISTOR	KTC3198Y	1
Q545	HVTKTC3198YT	TRANSISTOR	KTC3198Y	1
Q556	HVTKTC3200GRT	TRANSISTOR	KTC3200GR	1
Q557	HVTKTC3200GRT	TRANSISTOR	KTC3200GR	1
Q558	HVTKTC3200GRT	TRANSISTOR	KTC3200GR	1
Q559	HVTKTC3200GRT	TRANSISTOR	KTC3200GR	1
Q560	HVTKTC3200GRT	TRANSISTOR	KTC3200GR	1
Q561	HVTKTC3200GRT	TRANSISTOR	KTC3200GR	1
Q562	HVTKTC3200GRT	TRANSISTOR	KTC3200GR	1
Q563	HVTKTC3200GRT	TRANSISTOR	KTC3200GR	1
Q564	HVTKTC3200GRT	TRANSISTOR	KTC3200GR	1
Q565	HVTKTC3200GRT	TRANSISTOR	KTC3200GR	1
Q601	HVTKTA1268GRT	TRANSISTOR	KTA1268GR	1
Q602	HVTKTA1268GRT	TRANSISTOR	KTA1268GR	1
Q603	HVTKTA1268GRT	TRANSISTOR	KTA1268GR	1
Q604	HVTKTA1268GRT	TRANSISTOR	KTA1268GR	1
Q605	HVTKTA1268GRT	TRANSISTOR	KTA1268GR	1
Q681	KVTKSC2785YT	TRANSISTOR	KSC2785Y	1
Q682	KVTKSC2785YT	TRANSISTOR	KSC2785Y	1
Q683	KVTKSC2785YT	TRANSISTOR	KSC2785Y	1
Q684	KVTKSC2785YT	TRANSISTOR	KSC2785Y	1
Q685	KVTKSC2785YT	TRANSISTOR	KSC2785Y	1
Q706	HVTKTC2874BT	TRANSISTOR , MUTE	KTC2874B	1
Q801	KVTKSC2785YT	TRANSISTOR	KSC2785Y	1
Q812	HVTKTA1268GRT	TRANSISTOR	KTA1268GR	1
Q813	HVTKTC3200GRT	TRANSISTOR	KTC3200GR	1
Q816	HVTKTA1268GRT	TRANSISTOR	KTA1268GR	1
Q818	HVTKTC3200GRT	TRANSISTOR	KTC3200GR	1
Q819	HVTKTC3200GRT	TRANSISTOR	KTC3200GR	1
Q820	HVTKTC3200GRT	TRANSISTOR	KTC3200GR	1
Q824	HVTKTC3198YT	TRANSISTOR	KTC3198Y	1
Q826	HVTKTC2874BT	TRANSISTOR , MUTE	KTC2874B	1
Q901	KVTKSC2785YT	TRANSISTOR	KSC2785Y	1
Q938	HVTKRA107MT	TRANSISTOR	KRA107M	1
Q939	HVTKRA107MT	TRANSISTOR	KRA107M	1
Q942	KVTKSC2785YT	TRANSISTOR	KSC2785Y	1
Q943	KVTKSC2785YT	TRANSISTOR	KSC2785Y	1
Q951	HVTKRC107MT	TRANSISTOR	KRC107M	1
Q952	HVTKRA107MT	TRANSISTOR	KRA107M	1
Q960	HVTKRC107MT	TRANSISTOR	KRC107M	1
Q961	HVTKTA1024YT	TRANSISTOR	KTA1024Y	1
Q969	HVTKTC2874BT	TRANSISTOR , MUTE	KTC2874B	1
Q970	HVTKTC2874BT	TRANSISTOR , MUTE	KTC2874B	1
Q971	HVTKTC2874BT	TRANSISTOR , MUTE	KTC2874B	1
Q972	HVTKTC2874BT	TRANSISTOR , MUTE	KTC2874B	1
Q973	HVTKTC2874BT	TRANSISTOR , MUTE	KTC2874B	1
Q991	HVTKRC107MT	TRANSISTOR	KRC107M	1
Q992	HVTKRA107MT	TRANSISTOR	KRA107M	1
Q652	HVT2SB1560-OKM	TRANSISTOR , POWER	2SB1560	1
Q653	HVT2SB1560-OKM	TRANSISTOR , POWER	2SB1560	1
Q654	HVT2SB1560-OKM	TRANSISTOR , POWER	2SB1560	1
Q655	HVT2SB1560-OKM	TRANSISTOR , POWER	2SB1560	1
Q657	HVT2SD2390-OKM	TRANSISTOR , POWER	2SD2390	1
Q658	HVT2SD2390-OKM	TRANSISTOR , POWER	2SD2390	1
Q659	HVT2SD2390-OKM	TRANSISTOR , POWER	2SD2390	1
Q660	HVT2SD2390-OKM	TRANSISTOR , POWER	2SD2390	1
Q661	HVT2SB1560-OKM	TRANSISTOR , POWER	2SB1560	1

Ref. Designator	Part Number	Description		Qty
<b>MAIN/VIDEO/BIAS/DIGITAL PCB ASS'Y SECTION 2</b>				
Q670	HVT2SD2390-OKM	TRANSISTOR , POWER	2SD2390	1
Q803	HVT2SD2390-OKM	TRANSISTOR , POWER	2SD2390	1
Q804	HVT2SB1560-OKM	TRANSISTOR , POWER	2SB1560	1
Q858	HVT2SA1360O	TRANSISTOR	2SA1360O	1
Q871	HVT2SA1360O	TRANSISTOR	2SA1360O	1
Q872	HVT2SA1360O	TRANSISTOR	2SA1360O	1
Q874	HVT2SA1360O	TRANSISTOR	2SA1360O	1
Q875	HVT2SA1360O	TRANSISTOR	2SA1360O	1
Q876	HVT2SA1360O	TRANSISTOR	2SA1360O	1
Q881	HVT2SC3423O	TRANSISTOR	2SC3423O	1
Q882	HVT2SC3423O	TRANSISTOR	2SC3423O	1
Q883	HVT2SC3423O	TRANSISTOR	2SC3423O	1
Q884	HVT2SC3423O	TRANSISTOR	2SC3423O	1
Q885	HVT2SC3423O	TRANSISTOR	2SC3423O	1
Q886	HVT2SC3423O	TRANSISTOR	2SC3423O	1
D971	HVD1SS133MT	DIODE	1SS133	1
IC94	HVIMC7805C	I.C, REGULATOR	FAIRCHILD	1
<i>Resistors</i>				
R501	CRD20TJ433T	RES , CARBON	43K OHM 1/5W J	1
R502	CRD20TJ433T	RES , CARBON	43K OHM 1/5W J	1
R503	CRD20TJ433T	RES , CARBON	43K OHM 1/5W J	1
R504	CRD20TJ433T	RES , CARBON	43K OHM 1/5W J	1
R505	CRD20TJ433T	RES , CARBON	43K OHM 1/5W J	1
R506	CRD20TJ333T	RES , CARBON	33K OHM 1/5W J	1
R507	CRD20TJ333T	RES , CARBON	33K OHM 1/5W J	1
R508	CRD20TJ333T	RES , CARBON	33K OHM 1/5W J	1
R509	CRD20TJ333T	RES , CARBON	33K OHM 1/5W J	1
R510	CRD20TJ333T	RES , CARBON	33K OHM 1/5W J	1
R511	CRD20TJ152T	RES , CARBON	1.5K OHM 1/5W J	1
R512	CRD20TJ152T	RES , CARBON	1.5K OHM 1/5W J	1
R513	CRD20TJ152T	RES , CARBON	1.5K OHM 1/5W J	1
R514	CRD20TJ152T	RES , CARBON	1.5K OHM 1/5W J	1
R515	CRD20TJ152T	RES , CARBON	1.5K OHM 1/5W J	1
R516	CRD20TJ152T	RES , CARBON	1.5K OHM 1/5W J	1
R517	CRD20TJ152T	RES , CARBON	1.5K OHM 1/5W J	1
R518	CRD20TJ152T	RES , CARBON	1.5K OHM 1/5W J	1
R519	CRD20TJ152T	RES , CARBON	1.5K OHM 1/5W J	1
R520	CRD20TJ152T	RES , CARBON	1.5K OHM 1/5W J	1
R521	CRD20TJ471T	RES , CARBON	470 OHM 1/5W J	1
R522	CRD20TJ471T	RES , CARBON	470 OHM 1/5W J	1
R523	CRD20TJ471T	RES , CARBON	470 OHM 1/5W J	1
R524	CRD20TJ471T	RES , CARBON	470 OHM 1/5W J	1
R525	CRD20TJ471T	RES , CARBON	470 OHM 1/5W J	1
R531	CRD20TJ221T	RES , CARBON	220 OHM 1/5W J	1
R532	CRD20TJ221T	RES , CARBON	220 OHM 1/5W J	1
R533	CRD20TJ221T	RES , CARBON	220 OHM 1/5W J	1
R534	CRD20TJ221T	RES , CARBON	220 OHM 1/5W J	1
R535	CRD20TJ221T	RES , CARBON	220 OHM 1/5W J	1
R536	CRD20TJ221T	RES , CARBON	220 OHM 1/5W J	1
R537	CRD20TJ221T	RES , CARBON	220 OHM 1/5W J	1
R538	CRD20TJ221T	RES , CARBON	220 OHM 1/5W J	1
R539	CRD20TJ221T	RES , CARBON	220 OHM 1/5W J	1
R540	CRD20TJ221T	RES , CARBON	220 OHM 1/5W J	1
R541	CRD20TJ271T	RES , CARBON	270 OHM 1/5W J	1
R542	CRD20TJ271T	RES , CARBON	270 OHM 1/5W J	1
R543	CRD20TJ271T	RES , CARBON	270 OHM 1/5W J	1

Ref. Designator	Part Number	Description		Qty
<b>MAIN/VIDEO/BIAS/DIGITAL PCB ASS'Y SECTION 2</b>				
R544	CRD20TJ271T	RES , CARBON	270 OHM 1/5W J	1
R545	CRD20TJ271T	RES , CARBON	270 OHM 1/5W J	1
R556	CRD20TJ273T	RES , CARBON	27K OHM 1/5W J	1
R557	CRD20TJ273T	RES , CARBON	27K OHM 1/5W J	1
R558	CRD20TJ273T	RES , CARBON	27K OHM 1/5W J	1
R559	CRD20TJ273T	RES , CARBON	27K OHM 1/5W J	1
R560	CRD20TJ273T	RES , CARBON	27K OHM 1/5W J	1
R561	CRD20TJ182T	RES , CARBON	1.8K OHM 1/5W J	1
R562	CRD20TJ182T	RES , CARBON	1.8K OHM 1/5W J	1
R564	CRD20TJ182T	RES , CARBON	1.8K OHM 1/5W J	1
R566	CRD20TJ561T	RES , CARBON	560 OHM 1/5W J	1
R567	CRD20TJ561T	RES , CARBON	560 OHM 1/5W J	1
R568	CRD20TJ561T	RES , CARBON	560 OHM 1/5W J	1
R569	CRD20TJ561T	RES , CARBON	560 OHM 1/5W J	1
R570	CRD20TJ561T	RES , CARBON	560 OHM 1/5W J	1
R571	CRD20TJ561T	RES , CARBON	560 OHM 1/5W J	1
R572	CRD20TJ561T	RES , CARBON	560 OHM 1/5W J	1
R573	CRD20TJ561T	RES , CARBON	560 OHM 1/5W J	1
R574	CRD20TJ561T	RES , CARBON	560 OHM 1/5W J	1
R575	CRD20TJ561T	RES , CARBON	560 OHM 1/5W J	1
R576	CRD20TJ100T	RES , CARBON	10 OHM 1/5W J	1
R577	CRD20TJ100T	RES , CARBON	10 OHM 1/5W J	1
R578	CRD20TJ100T	RES , CARBON	10 OHM 1/5W J	1
R579	CRD20TJ100T	RES , CARBON	10 OHM 1/5W J	1
R580	CRD20TJ100T	RES , CARBON	10 OHM 1/5W J	1
R581	CRD20TJ561T	RES , CARBON	560 OHM 1/5W J	1
R582	CRD20TJ561T	RES , CARBON	560 OHM 1/5W J	1
R583	CRD20TJ561T	RES , CARBON	560 OHM 1/5W J	1
R584	CRD20TJ561T	RES , CARBON	560 OHM 1/5W J	1
R585	CRD20TJ561T	RES , CARBON	560 OHM 1/5W J	1
R586	CRD20TJ561T	RES , CARBON	560 OHM 1/5W J	1
R587	CRD20TJ561T	RES , CARBON	560 OHM 1/5W J	1
R588	CRD20TJ561T	RES , CARBON	560 OHM 1/5W J	1
R589	CRD20TJ561T	RES , CARBON	560 OHM 1/5W J	1
R590	CRD20TJ561T	RES , CARBON	560 OHM 1/5W J	1
R591	CRD20TJ561T	RES , CARBON	560 OHM 1/5W J	1
R592	CRD20TJ561T	RES , CARBON	560 OHM 1/5W J	1
R593	CRD20TJ561T	RES , CARBON	560 OHM 1/5W J	1
R594	CRD20TJ561T	RES , CARBON	560 OHM 1/5W J	1
R595	CRD20TJ561T	RES , CARBON	560 OHM 1/5W J	1
R596	CRD20TJ561T	RES , CARBON	560 OHM 1/5W J	1
R597	CRD20TJ561T	RES , CARBON	560 OHM 1/5W J	1
R598	CRD20TJ561T	RES , CARBON	560 OHM 1/5W J	1
R599	CRD20TJ561T	RES , CARBON	560 OHM 1/5W J	1
R600	CRD20TJ561T	RES , CARBON	560 OHM 1/5W J	1
R601	CRD20TJ223T	RES , CARBON	22K OHM 1/5W J	1
R602	CRD20TJ223T	RES , CARBON	22K OHM 1/5W J	1
R603	CRD20TJ223T	RES , CARBON	22K OHM 1/5W J	1
R604	CRD20TJ223T	RES , CARBON	22K OHM 1/5W J	1
R605	CRD20TJ223T	RES , CARBON	22K OHM 1/5W J	1
R606	CRD20TJ223T	RES , CARBON	22K OHM 1/5W J	1
R607	CRD20TJ223T	RES , CARBON	22K OHM 1/5W J	1
R608	CRD20TJ223T	RES , CARBON	22K OHM 1/5W J	1
R609	CRD20TJ223T	RES , CARBON	22K OHM 1/5W J	1
R610	CRD20TJ223T	RES , CARBON	22K OHM 1/5W J	1
R611	CRD20TJ100T	RES , CARBON	10 OHM 1/5W J	1
R631	KRD25FJ180T	RES , CARBON	18 OHM 1/4W F	1
R632	KRD25FJ180T	RES , CARBON	18 OHM 1/4W F	1

Ref. Designator	Part Number	Description		Qty
<b>MAIN/VIDEO/BIAS/DIGITAL PCB ASS'Y SECTION 2</b>				
R633	KRD25FJ180T	RES , CARBON	18 OHM 1/4W F	1
R634	KRD25FJ180T	RES , CARBON	18 OHM 1/4W F	1
R635	KRD25FJ180T	RES , CARBON	18 OHM 1/4W F	1
R636	KRD25FJ180T	RES , CARBON	18 OHM 1/4W F	1
R637	KRD25FJ180T	RES , CARBON	18 OHM 1/4W F	1
R638	KRD25FJ180T	RES , CARBON	18 OHM 1/4W F	1
R639	KRD25FJ180T	RES , CARBON	18 OHM 1/4W F	1
R640	KRD25FJ180T	RES , CARBON	18 OHM 1/4W F	1
R646	KRD25FJ3R3T	RES , CARBON	3.3 OHM 1/4W F	1
R647	KRD25FJ3R3T	RES , CARBON	3.3 OHM 1/4W F	1
R648	KRD25FJ3R3T	RES , CARBON	3.3 OHM 1/4W F	1
R649	KRD25FJ3R3T	RES , CARBON	3.3 OHM 1/4W F	1
R650	KRD25FJ3R3T	RES , CARBON	3.3 OHM 1/4W F	1
R651	KRD25FJ3R3T	RES , CARBON	3.3 OHM 1/4W F	1
R652	KRD25FJ3R3T	RES , CARBON	3.3 OHM 1/4W F	1
R653	KRD25FJ3R3T	RES , CARBON	3.3 OHM 1/4W F	1
R654	KRD25FJ3R3T	RES , CARBON	3.3 OHM 1/4W F	1
R655	KRD25FJ3R3T	RES , CARBON	3.3 OHM 1/4W F	1
R666	CRD25TJ470T	RES , CARBON	47 HOM 1/4W J	1
R667	CRD25TJ470T	RES , CARBON	47 HOM 1/4W J	1
R668	CRD25TJ470T	RES , CARBON	47 HOM 1/4W J	1
R669	CRD25TJ470T	RES , CARBON	47 HOM 1/4W J	1
R670	CRD25TJ470T	RES , CARBON	47 HOM 1/4W J	1
R671	CRD20TJ911T	RES , CARBON	910 OHM 1/5W J	1
R672	CRD20TJ911T	RES , CARBON	910 OHM 1/5W J	1
R673	CRD20TJ911T	RES , CARBON	910 OHM 1/5W J	1
R674	CRD20TJ911T	RES , CARBON	910 OHM 1/5W J	1
R675	CRD20TJ911T	RES , CARBON	910 OHM 1/5W J	1
R676	CRD20TJ182T	RES , CARBON	1.8K OHM 1/5W J	1
R677	CRD20TJ182T	RES , CARBON	1.8K OHM 1/5W J	1
R678	CRD20TJ182T	RES , CARBON	1.8K OHM 1/5W J	1
R679	CRD20TJ182T	RES , CARBON	1.8K OHM 1/5W J	1
R680	CRD20TJ182T	RES , CARBON	1.8K OHM 1/5W J	1
R681	CRD20TJ562T	RES , CARBON	5.6K OHM 1/5W J	1
R682	CRD20TJ562T	RES , CARBON	5.6K OHM 1/5W J	1
R683	CRD20TJ562T	RES , CARBON	5.6K OHM 1/5W J	1
R684	CRD20TJ562T	RES , CARBON	5.6K OHM 1/5W J	1
R685	CRD20TJ562T	RES , CARBON	5.6K OHM 1/5W J	1
R686	CRD20TJ103T	RES , CARBON	10K OHM 1/5W J	1
R687	CRD20TJ103T	RES , CARBON	10K OHM 1/5W J	1
R688	CRD20TJ103T	RES , CARBON	10K OHM 1/5W J	1
R689	CRD20TJ103T	RES , CARBON	10K OHM 1/5W J	1
R690	CRD20TJ103T	RES , CARBON	10K OHM 1/5W J	1
R696	CRD25TJ470T	RES , CARBON	47 OHM 1/4W	1
R697	CRD25TJ470T	RES , CARBON	47 OHM 1/4W	1
R698	CRD25TJ470T	RES , CARBON	47 OHM 1/4W	1
R699	CRD25TJ470T	RES , CARBON	47 OHM 1/4W	1
R700	CRD25TJ470T	RES , CARBON	47 OHM 1/4W	1
R706	CRD20TJ821T	RES , CARBON	820 OHM 1/5W J	1
R716	CRD20TJ472T	RES , CARBON	4.7K OHM 1/5W J	1
R726	CRD20TJ104T	RES , CARBON	100K OHM 1/5W J	1
R771	CRD20TJ750T	RES , CARBON	75 OHM 1/5W J	1
R772	CRD20TJ750T	RES , CARBON	75 OHM 1/5W J	1
R773	CRD20TJ750T	RES , CARBON	75 OHM 1/5W J	1
R774	CRD20TJ750T	RES , CARBON	75 OHM 1/5W J	1
R775	CRD20TJ750T	RES , CARBON	75 OHM 1/5W J	1
R776	CRD20TJ750T	RES , CARBON	75 OHM 1/5W J	1
R781	CRD20TJ750T	RES , CARBON	75 OHM 1/5W J	1

Ref. Designator	Part Number	Description		Qty
<b>MAIN/VIDEO/BIAS/DIGITAL PCB ASS'Y SECTION 2</b>				
R782	CRD20TJ750T	RES , CARBON	75 OHM 1/5W J	1
R783	CRD20TJ750T	RES , CARBON	75 OHM 1/5W J	1
R784	CRD20TJ750T	RES , CARBON	75 OHM 1/5W J	1
R785	CRD20TJ750T	RES , CARBON	75 OHM 1/5W J	1
R786	CRD20TJ750T	RES , CARBON	75 OHM 1/5W J	1
R801	CRD20TJ103T	RES , CARBON	10K OHM 1/5W J	1
R803	CRD20TJ562T	RES , CARBON	5.6K OHM 1/5W J	1
R805	CRD20TJ911T	RES , CARBON	910 OHM 1/5W J	1
R808	CRD20TJ182T	RES , CARBON	1.8K OHM 1/5W J	1
R812	CRD25TJ470T	RES , CARBON	47 OHM 1/4W	1
R813	CRD25TJ470T	RES , CARBON	47 OHM 1/4W	1
R817	KRD25FJ3R3T	RES , CARBON	3.3 OHM 1/4W F	1
R818	KRD25FJ3R3T	RES , CARBON	3.3 OHM 1/4W F	1
R821	KRD25FJ180T	RES , CARBON	18 OHM 1/4W F	1
R822	KRD25FJ180T	RES , CARBON	18 OHM 1/4W F	1
R830	CRD20TJ223T	RES , CARBON	22K OHM 1/5W J	1
R831	CRD20TJ223T	RES , CARBON	22K OHM 1/5W J	1
R834	CRD20TJ561T	RES , CARBON	560 OHM 1/5W J	1
R835	CRD20TJ561T	RES , CARBON	560 OHM 1/5W J	1
R836	CRD20TJ561T	RES , CARBON	560 OHM 1/5W J	1
R837	CRD20TJ561T	RES , CARBON	560 OHM 1/5W J	1
R842	CRD20TJ561T	RES , CARBON	560 OHM 1/5W J	1
R843	CRD20TJ561T	RES , CARBON	560 OHM 1/5W J	1
R848	CRD20TJ273T	RES , CARBON	27K OHM 1/5W J	1
R850	CRD20TJ182T	RES , CARBON	1.8K OHM 1/5W J	1
R852	CRD20TJ152T	RES , CARBON	1.5K OHM 1/5W J	1
R853	CRD20TJ152T	RES , CARBON	1.5K OHM 1/5W J	1
R856	CRD20TJ221T	RES , CARBON	220 OHM 1/5W J	1
R857	CRD20TJ221T	RES , CARBON	220 OHM 1/5W J	1
R860	CRD20TJ271T	RES , CARBON	270 OHM 1/5W J	1
R862	CRD20TJ333T	RES , CARBON	33K OHM 1/5W J	1
R864	CRD20TJ331T	RES , CARBON	330 OHM 1/5W J	1
R866	CRD20TJ472T	RES , CARBON	4.7K OHM 1/5W J	1
R868	CRD20TJ473T	RES , CARBON	47K OHM 1/5W J	1
R870	CRD20TJ433T	RES , CARBON	43K OHM 1/5W J	1
R872	CRD20TJ471T	RES , CARBON	470 OHM 1/5W J	1
R900	CRD20TJ103T	RES , CARBON	10K OHM 1/5W J	1
R901	CRD25TJ393T	RES , CARBON	39K OHM 1/4W J	1
R902	CRD25TJ393T	RES , CARBON	39K OHM 1/4W J	1
R903	CRD25TJ393T	RES , CARBON	39K OHM 1/4W J	1
R906	CRD25TJ393T	RES , CARBON	39K OHM 1/4W J	1
R910	CRD20TJ105T	RES , CARBON	1M OHM 1/5W J	1
R911	CRD25TJ680T	RES , CARBON	68 OHM 1/4W J	1
R917	CRD25TJ393T	RES , CARBON	39K OHM 1/4W J	1
R918	CRD25TJ393T	RES , CARBON	39K OHM 1/4W J	1
R919	CRD25TJ393T	RES , CARBON	39K OHM 1/4W J	1
R920	CRD25TJ393T	RES , CARBON	39K OHM 1/4W J	1
R932	CRD20TJ103T	RES , CARBON	10K OHM 1/5W J	1
R939	CRD20TJ472T	RES , CARBON	4.7K OHM 1/5W J	1
R940	CRD20TJ152T	RES , CARBON	1.5K OHM 1/5W J	1
R941	CRD20TJ223T	RES , CARBON	22K OHM 1/5W J	1
R942	CRD20TJ223T	RES , CARBON	22K OHM 1/5W J	1
R943	CRD20TJ223T	RES , CARBON	22K OHM 1/5W J	1
R944	CRD25TJ223T	RES , CARBON	22K OHM 1/4W J	1
R945	CRD20TJ223T	RES , CARBON	22K OHM 1/5W J	1
R946	CRD25TJ223T	RES , CARBON	22K OHM 1/4W J	1
R947	CRD20TJ223T	RES , CARBON	22K OHM 1/5W J	1
R955	CRD20TJ393T	RES , CARBON	39K OHM 1/4W J	1

Ref. Designator	Part Number	Description		Qty
<b>MAIN/VIDEO/BIAS/DIGITAL PCB ASS'Y SECTION 2</b>				
R956	CRD20TJ394T	RES , CARBON	390K OHM 1/4W J	1
R957	CRD20TJ153T	RES , CARBON	15K OHM 1/5W J	1
R960	CRD20TJ392T	RES , CARBON	3.9K OHM 1/4W J	1
R961	CRD20TJ331T	RES , CARBON	330 OHM 1/5W J	1
R962	CRD20TJ273T	RES , CARBON	27K OHM 1/5W J	1
R963	CRD20TJ105T	RES , CARBON	1M OHM 1/5W J	1
R966	CRD20TJ472T	RES , CARBON	4.7K OHM 1/5W J	1
R969	CRD20TJ472T	RES , CARBON	4.7K OHM 1/5W J	1
R970	CRD20TJ472T	RES , CARBON	4.7K OHM 1/5W J	1
R971	CRD20TJ472T	RES , CARBON	4.7K OHM 1/5W J	1
R972	CRD20TJ472T	RES , CARBON	4.7K OHM 1/5W J	1
R973	CRD20TJ472T	RES , CARBON	4.7K OHM 1/5W J	1
R974	CRD20TJ331T	RES , CARBON	330 OHM 1/5W J	1
R975	CRD20TJ331T	RES , CARBON	330 OHM 1/5W J	1
R976	CRD20TJ331T	RES , CARBON	330 OHM 1/5W J	1
R977	CRD20TJ331T	RES , CARBON	330 OHM 1/5W J	1
R978	CRD20TJ331T	RES , CARBON	330 OHM 1/5W J	1
R979	CRD20TJ473T	RES , CARBON	47K OHM 1/5W J	1
R980	CRD20TJ473T	RES , CARBON	47K OHM 1/5W J	1
R981	CRD20TJ473T	RES , CARBON	47K OHM 1/5W J	1
R982	CRD20TJ473T	RES , CARBON	47K OHM 1/5W J	1
R983	CRD20TJ473T	RES , CARBON	47K OHM 1/5W J	1
R986	CRD20TJ102T	RES , CARBON	1K OHM 1/5W J	1
R987	CRD20TJ561T	RES , CARBON	560 OHM 1/5W J	1
R988	CRD20TJ562T	RES , CARBON	5.6K OHM 1/5W J	1
R991	CRD20TJ822T	RES , CARBON	8.2K OHM 1/5W J	1
R992	CRD20TJ562T	RES , CARBON	5.6K OHM 1/5W J	1
R998	CRD20TJ103T	RES , CARBON	10K OHM 1/5W J	1
R563	CRD20TJ182T	RES , CARBON	1.8K OHM 1/5W J	1
R565	CRD20TJ182T	RES , CARBON	1.8K OHM 1/5W J	1
R656	CRF5EKR27HX2K	RES , CEMENT	0.27ohm X 2	1
R657	CRF5EKR27HX2K	RES , CEMENT	0.27ohm X 2	1
R658	CRF5EKR27HX2K	RES , CEMENT	0.27ohm X 2	1
R659	CRF5EKR27HX2K	RES , CEMENT	0.27ohm X 2	1
R660	CRF5EKR27HX2K	RES , CEMENT	0.27ohm X 2	1
R810	CRF5EKR27HX2K	RES , CEMENT	0.27ohm X 2	1
R904	HRDERC12UGK335T	RES , CARBON JP	3.3M OHM	1
R905	CRG1ANJ100H	RES , METAL OXIDE FILM	10 OHM	1
R990	CRG1ANJ100H	RES , METAL OXIDE FILM	10 OHM	1
R993	CRG1ANJ100H	RES , METAL OXIDE FILM	10 OHM	1
R995	CRG1ANJ100H	RES , METAL OXIDE FILM	10 OHM	1
R996	CRG1ANJ100H	RES , METAL OXIDE FILM	10 OHM	1
R997	CRG1ANJ100H	RES , METAL OXIDE FILM	10 OHM	1
R999	CRG1ANJ100H	RES , METAL OXIDE FILM	10 OHM	1
<i>Miscellaneous</i>				
	CMD1A387	BRACKET , PCB	BRACKET	1
	CMYAVR135	HEAT SINK ASS'Y	ASS'Y	1
	CHD1A012	SCREW , TR	SCREW	18
	CHD3A012	SCREW , TR	SCREW	3
	CMD1A398	BRACKET , PCB	BRACKET	2
	CMD1A417	BRACKET , PCB	BRACKET	2
	CMY1A248	HEAT SINK	HEAT SINK	1
	CTB3+8J	SCREW	SCREW	6
	CTW3+8J	SCREW	SCREW	3
BN19	CWB3FE03250UP	WIRE ASS'Y	WIRE	1
BN20	CWB3FB43280UP	WIRE ASS'Y	WIRE	1



Ref. Designator	Part Number	Description		Qty
<b>MAIN/VIDEO/BIAS/DIGITAL PCB ASS'Y SECTION 2</b>				
BN82	CWB1C902050EN	WIRE ASS'Y	WIRE	1
BN83	CWB1C902050EN	WIRE ASS'Y	WIRE	1
BN84	CWB1C902050EN	WIRE ASS'Y	WIRE	1
BN85	CWB1C902050EN	WIRE ASS'Y	WIRE	1
BN86	CWB1C902050EN	WIRE ASS'Y	WIRE	1
BN87	CWB1C902050EN	WIRE ASS'Y	WIRE	1
BN98	BJP08GA130ZK	WAFER	WAFER	1
BN98	HJP08GA130ZK	WAFER	WAFER	1
BN99	CWB1C902050EN	WIRE ASS'Y	WIRE	1
CN61	KJP02GA01ZM	WAFER	WAFER	1
CN62	KJP02GA01ZM	WAFER	WAFER	1
CN63	KJP02GA01ZM	WAFER	WAFER	1
CN64	KJP02GA01ZM	WAFER	WAFER	1
CN65	KJP02GA01ZM	WAFER	WAFER	1
CN66	KJP02GA01ZM	WAFER	WAFER	1
CN80	KJP11GA19ZM	WAFER	WAFER	1
CN91	KJP03GA89ZM	WAFER	WAFER	1
CN94	KJP13GA98ZM	WAFER	WAFER	1
CN95	KJP08GA98ZM	WAFER	WAFER	1
CN99	CJP02GA19ZY	WAFER, 2PIN	WAFER	1
ET01	CNE75	PLATE , EARTH	PLATE	1
ET03	CNE75	PLATE , EARTH	PLATE	1
JK90	CJJ4M040Z	JACK , BOARD (SW)	JACK	1
JK91	CJJ5R006Z	TERMINAL , SPEAKER	SPEAKER TERMINAL	1
JK92	CJJ5R007Z	TERMINAL , SPEAKER	SPEAKER TERMINAL	1
JW90	CWEE212120VV	WIRE ASS'Y	WIRE	1
JW91	CWE8212180VV	WIRE ASS'Y	WIRE	1
JW99	CWE8202150AA	WIRE ASS'Y	WIRE	1
L501	CLEY0R5KAK	COIL , SPEAKER	0.5UH K	1
L502	CLEY0R5KAK	COIL , SPEAKER	0.5UH K	1
L503	CLEY0R5KAK	COIL , SPEAKER	0.5UH K	1
L504	CLEY0R5KAK	COIL , SPEAKER	0.5UH K	1
L505	CLEY0R5KAK	COIL , SPEAKER	0.5UH K	1
L506	CLEY0R5KAK	COIL , SPEAKER	0.5UH K	1
RY94	HSL1A008ZE	RELAY	SDT-S-112DMR	1
TH91	KRTP42T7D330B	THERMAL SENSOR , POSISTOR	POSISTOR	1
T902	CLT5J033ZU	TRANS , SUB	SUB TRANS	1
T901	CLT5V037ZU	TRANS , POWER	MAIN TRANS	1
	CTB3+10GFZ	SCREW	SCREW	29
	CTB3+6J	SCREW	SCREW	13
	CTB3+8J	SCREW	SCREW	9
	CTB3+8JFZ	SCREW	SCREW	1
	CTW3+12J	SCREW	SCREW	2
	CTW3+8J	SCREW	SCREW	7
	CUA1A229	CHASSIS , BOTTOM	BOTTOM CHASSIS	1
	KHE36-3	CLAMPER , WIRE	CLAMPER	2
	KHG1A050	RUBBER , CUSHION	RUBBER	4
	KHG1A308	CUSHION, TRANS	CUSHION	1
	KHR1A028	BUSHING , AC CORD	BUSHING	1
	KHR301	CLAMPER	CLAMPER	16
CB13	CWC1C4A13B080B	CABLE , CARD 80mm 13P		1
CB15	CWC1C4A13B100B	CABLE , CARD 100mm 13P		1
F903	KBA2C6300TLUZ	FUSE	6.3A 250V	1
F904	KBA2C6300TLUZ	FUSE	6.3A 250V	1
F905	KBA2C6300TLUZ	FUSE	6.3A 250V	1
F906	KBA2C6300TLUZ	FUSE	6.3A 250V	1
F907	KBA2C6300TLUZ	FUSE	6.3A 250V	1
F903-F907	KJCF5S	HOLDER , FUSE	HOLDER	8

Ref. Designator	Part Number	Description		Qty
<b>MAIN/VIDEO/BIAS/DIGITAL PCB ASS'Y SECTION 2</b>				
	CHD1A012Z	SCREW , SPECIAL	SCREW	2
	CHD1A023	SCREW , TRANS	SCREW	4
	CHD4A012	SCREW , TR	SCREW	5
	CHE170	HOLDER , PCB	HOLDER	2
	CHG1A104	CUSHION , EVA	CUSHION	1
	CHG1A157	CUSHION , RUBBER	CUSHION	1
	CHG1A160	RUBBER	RUBBER	1
	CJA523FBYA	CORD , POWER	POWER CORD	1
	CKF14A254Z	PANEL , REAR	REAR PANEL	1
	CLZ9W003Z	FERRITE , RING	RING CORE	1
	CMD1A487	BRACKET , TRANS	BRACKET	1
	CHG1A218	CUSHION	CUSHION	1
L501	HLQ02C101JT	COIL , AXAIL	100UH,J	1
L502	KLQ5R6J405T	COIL, PEAKING(RADIAL)	5.6UH J 4X5	1
L503	KLQ220J405T	COIL, PEAKING(RADIAL)	22UH J 4X5	1
	CMC1A284	PLATE , SHIELD	PLATE	1
BN14	CWB4F232450PU	WIRE ASS'Y	WIRE	1
BN17	KJP12GB143ZP	DIP SOCKET	SOCKET	1
BN61	CWB2B903150EN	WIRE ASS'Y	WIRE	1
BN91	CWB4FE53130PU	WIRE ASS'Y	WIRE	1
BN96	CWB1C908150BM	WIRE ASS'Y	WIRE	1
BN97	CWB2B902200EN	WIRE ASS'Y	WIRE	1
CN13	CJP05GA01ZY	CON WAFER YMW025-05R	CONNECTOR	1
CN19	KJP03GA90ZM	WAFER	WAFER	1
CN20	KJP04GA90ZM	WAFER	WAFER	1
CN21	KJP02GA89ZM	WAFER	WAFER	1
CN32	CJP02GB46ZY	WAFER, ANGLE, 2PIN	WAFER	1
CN33	CJP02GB46ZY	WAFER, ANGLE, 2PIN	WAFER	1
CN34	CJP02GB46ZY	WAFER, ANGLE, 2PIN	WAFER	1
CN35	CJP02GB46ZY	WAFER, ANGLE, 2PIN	WAFER	1
CN36	CJP02GB46ZY	WAFER, ANGLE, 2PIN	WAFER	1
CN37	CJP02GB46ZY	WAFER, ANGLE, 2PIN	WAFER	1
CN41	CJP06GA19ZY	WAFER, STRAIGHT, 6PIN	WAFER	1
CN43	CJP13GA115ZY	WAFER , CARD CABLE	WAFER	1
CN61	CJP03GA19ZY	WAFER, STRAIGHT, 3PIN	WAFER	1
CN62	CJP04GA19ZY	WAFER, STRAIGHT, 4PIN	WAFER	1
CN81	CJP08GA01ZY	WAFER, STRAIGHT, 8PIN	WAFER	1
CN84	KJP02KA060ZY	WAFER	WAFER	1
CN96	CJP08GA01ZY	WAFER, STRAIGHT, 8PIN	WAFER	1
CN98	BJP08GB131ZK	WAFER	WAFER	1
CN98	HJP08GB131ZK	WAFER	WAFER	1
	CMY1A219	HEAT SINK (BRIDGE DIODE)	HEAT SINK	1
	CTB3+12J	SCREW	SCREW	1
F901	KBA2D2500TLET	FUSE	2.5A	1
F902	KBA2D2500TLET	FUSE	2.5A	1
	CMY1A218	HEAT SINK(TR)	HEAT SINK	1
	CTB3+8J	SCREW	SCREW	1
	CNVM9011MS071L	<b>AVR 140 TUNER MODULE</b>		



= Target Spec =
AK4358  
192kHz 24-Bit 8ch DAC with DSD Input

GENERAL DESCRIPTION

The AK4358 is eight channels 24bit DAC corresponding to digital audio system. Using AKM's advanced multi bit architecture for its modulator the AK4358 delivers a wide dynamic range while preserving linearity for improved THD+N performance. The AK4358 has full differential SCF outputs, removing the need for AC coupling capacitors and increasing performance for systems with excessive clock jitter. The AK4358 accepts 192kHz PCM data and 1-Bit DSD data, ideal for a wide range of applications including DVD-Audio and SACD.

FEATURES

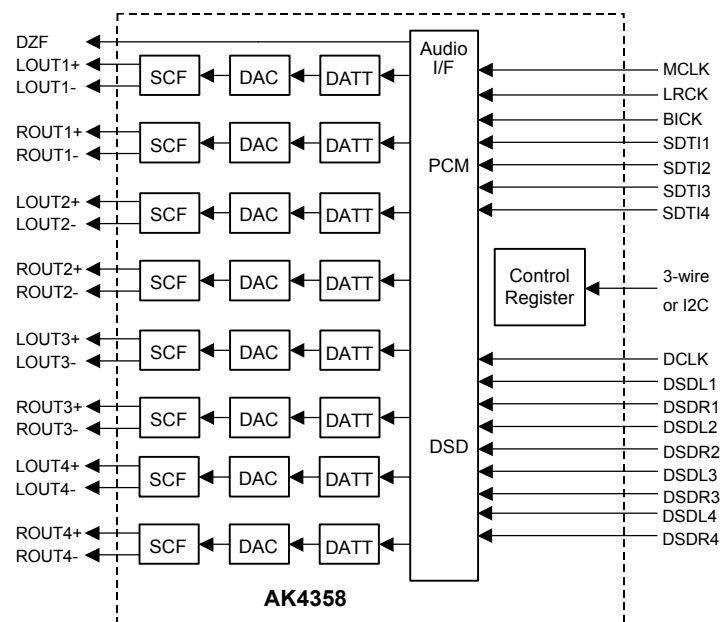
- Sampling Rate Ranging from 8kHz to 192kHz
- 24Bit 8 times Digital Filter with Slow roll-off option
- THD+N: -94dB
- DR, S/N: 114dB
- High Tolerance to Clock Jitter
- Low Distortion Differential Output
- DSD Data input available
- Channel Independent Digital De-emphasis for 32, 44.1 & 48kHz sampling
- Zero Detect function
- Channel Independent Digital Attenuator with soft-transition (3 Speed mode)
- Soft Mute
- 3-wire Serial and I<sup>2</sup>C Bus  $\mu$ P I/F for mode setting
- I/F format: MSB justified, LSB justified (16bit, 20bit, 24bit), I<sup>2</sup>S, TDM or DSD
- Master clock: 256fs, 384fs, 512fs or 768fs (PCM Normal Speed Mode)  
128fs, 192fs, 256fs or 384fs (PCM Double Speed Mode)  
128fs or 192fs (PCM Quad Speed Mode)  
512fs or 768fs (DSD Mode)
- Power Supply: 4.75 to 5.25V
- 48pin LQFP Package



■ **Ordering Guide**

AK4358VQ	-40 ~ +85°C	48LQFP
AKD4358	Evaluation Board for AK4358	

■ **Pin Layout (To be determined)**

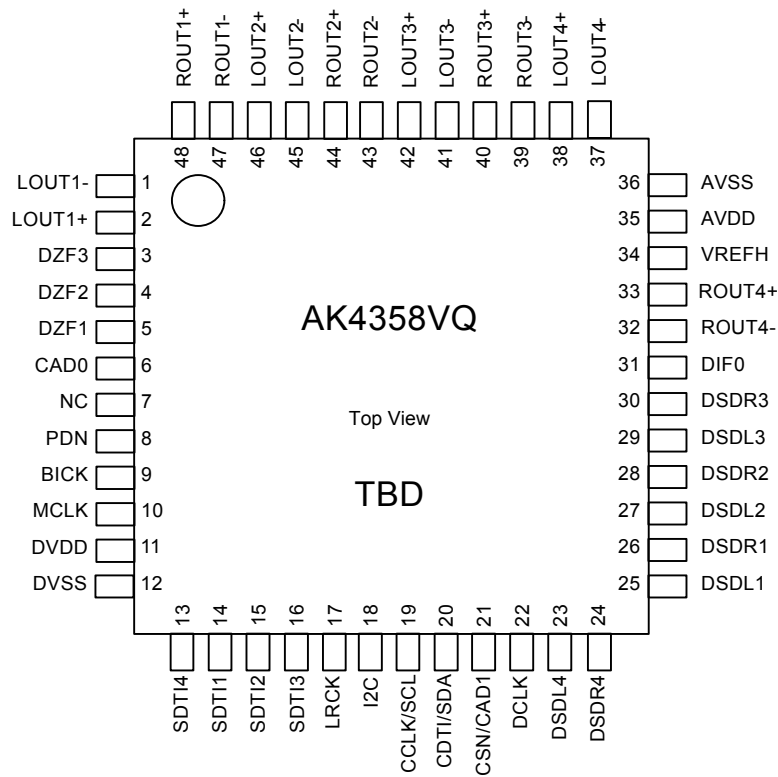

## ■ Compatibility with AK4357

### 1. Function & Performance

Functions	AK4357	AK4358
# of channels	6	8
DR	106dB	114B
48kHz/96kHz TDM	Not available	Available
I2C	Not available	Available
DSDM control	Pin/Register	Register
Input channel of DZF pin	Fixed	Programmable

### 2. Pin Configuration (To be determined)

Pin #	AK4357	AK4358
3	DZFL1	DZF3
4	DZFR1	DZF2
5	DZF23	DZF1
7	CAD1	NC
12	NC	DVSS
13	DVSS	SDTI4
18	SMUTE	I2C
22	DSDM	DCLK
23	DCLK	DSDL4
24	NC	DSDR4
32	DIF1	ROUT4-
33	DIF2	ROUT4+
37	AVSS	LOUT4-
38	AVSS	LOUT4-

### 3. Register

Addr	Bit	AK4357	AK4358
00H	D5	DZFM	0
01H	D6	0	PW4
04H	D7	ATT7	ATTE
05H	D7	ATT7	ATTE
06H	D7	ATT7	ATTE
07H	D7	ATT7	ATTE
08H	D7	ATT7	ATTE
09H	D7	ATT7	ATTE
0AH	D7, D6	0, 0	TDM1, TDM0
0BH		Not available	LOUT4 ATT Control
0CH		Not available	ROUT4 ATT Control
0DH		Not available	DZF1 control
0EH		Not available	DZF2 control
0FH		Not available	DZF3 control

ASAHI KASEI

AKM CONFIDENTIAL

IC 74

[AK4358]

## PIN/FUNCTION (TBD)

No.	Pin Name	I/O	Function
	LOUT1-	O	DAC1 Lch Negative Analog Output Pin
	LOUT1+	O	DAC1 Lch Positive Analog Output Pin
	DZF1	O	Zero Input Detect 1 Pin
	DZF2	O	Zero Input Detect 2 Pin
	DZF3	O	Zero Input Detect 3 Pin
	CAD0	I	Chip Address 0 Pin
	PDN	I	Power-Down Mode Pin When at "L", the AK4358 is in the power-down mode and is held in reset. The AK4358 should always be reset upon power-up.
	BICK	I	Audio Serial Data Clock Pin
	MCLK	I	Master Clock Input Pin An external TTL clock should be input on this pin.
	DVDD	-	Digital Power Supply Pin, +4.75~+5.25V
	DVSS	-	Digital Ground Pin
	SDTI1	I	DAC1 Audio Serial Data Input Pin
	SDTI2	I	DAC2 Audio Serial Data Input Pin
	SDTI3	I	DAC3 Audio Serial Data Input Pin
	SDTI4	I	DAC4 Audio Serial Data Input Pin
	LRCK	I	L/R Clock Pin
	I2C	I	Control Mode Select Pin "L": 3-wire Serial, "H": I <sup>2</sup> C Bus
	CCLK/SCL	I	Control Data Clock Pin I2C = "L": CCLK (3-wire Serial), I2C = "H": SCL (I <sup>2</sup> C Bus)
	CDTI/SDA	I/O	Control Data Input Pin I2C = "L": CDTI (3-wire Serial), I2C = "H": SDA (I <sup>2</sup> C Bus)
	CSN/CAD1	I	Chip Select Pin I2C = "L": CSN (3-wire Serial), I2C = "H": CAD1 (I <sup>2</sup> C Bus)
	DCLK	I	DSD Clock Pin
	DSDL1	I	DAC1 DSD Lch Data Input Pin
	DSDR1	I	DAC1 DSD Rch Data Input Pin
	DSDL2	I	DAC2 DSD Lch Data Input Pin
	DSDR2	I	DAC2 DSD Rch Data Input Pin
	DSDL3	I	DAC3 DSD Lch Data Input Pin
	DSDR3	I	DAC3 DSD Rch Data Input Pin
	DSDL4	I	DAC4 DSD Lch Data Input Pin
	DSDR4	I	DAC4 DSD Rch Data Input Pin
	DIF0	I	Audio Data Interface Format 0 Pin
	VREFH	I	Positive Voltage Reference Input Pin
	AVDD	-	Analog Power Supply Pin, +4.75~+5.25V
	AVSS	-	Analog Ground Pin
	ROUT4-	O	DAC4 Rch Negative Analog Output Pin
	ROUT4+	O	DAC4 Rch Positive Analog Output Pin
	LOUT4-	O	DAC4 Lch Negative Analog Output Pin
	LOUT4+	O	DAC4 Lch Positive Analog Output Pin
	ROUT3-	O	DAC3 Rch Negative Analog Output Pin
	ROUT3+	O	DAC3 Rch Positive Analog Output Pin
	LOUT3-	O	DAC3 Lch Negative Analog Output Pin
	LOUT3+	O	DAC3 Lch Positive Analog Output Pin
	ROUT2-	O	DAC2 Rch Negative Analog Output Pin
	ROUT2+	O	DAC2 Rch Positive Analog Output Pin
	LOUT2-	O	DAC2 Lch Negative Analog Output Pin
	LOUT2+	O	DAC2 Lch Positive Analog Output Pin
	ROUT1-	O	DAC1 Rch Negative Analog Output Pin

**mitsumi**

Video Switch · 75Ω driver · Y/C mix MM1501

# Video Switch · 75Ω driver · Y/C mix Monolithic IC MM1501 Series

## Outline

This IC extends the series of ICs for video/audio signal switching, with a 2-input 1-output single video switch, video signal/chroma signal 75Ω driver, and Y/C mixing circuit in one small package (SOT-26).

## Features

- (1) Low power consumption achieved.
- (2) Low power supply voltage realized.
- (3) Frequency bandwidth   without 75Ω driver: 10MHz                      with 75Ω driver: 7MHz
- (4) Cross talk   70dB   When 4.43MHz
- (5) With SAG measures pin (75Ω driver and Y/C mix driver)

## Package

- SOT-26A (with 75Ω driver)
- SOT-26B (without 75Ω driver)

## Applications

- (1) TV
- (2) VTR
- (3) Video camera
- (4) Digital still camera
- (5) Other visual equipment

## Line-up

Functions	Model Name	Input	Output	Clamp	6dB amp	75Ω driver	SAG measures pin	Power supply voltage
Switch	MM1501	2	1	×	×	×	×	4.5~13.0V
	MM1502			×	○	×	×	4.5~13.0V
	MM1503			○	×	×	×	4.5~13.0V
	MM1504			○	○	×	×	4.5~13.0V
	MM1505			×	×	○	×	4.5~13.0V
	MM1506			×	○	○	×	4.5~13.0V
	MM1507			○	×	○	×	4.5~13.0V
	MM1508			○	○	○	×	4.5~13.0V
Driver	MM1509	1	1	×	○	○	○	4.5~13.0V
	MM1510			○	○	○	○	4.5~13.0V
Y/C mix	MM1511	1	1	○/×	×	×	×	4.5~13.0V
	MM1512			○/×	○	○	○	4.5~13.0V

Block Diagram

■ MM1501

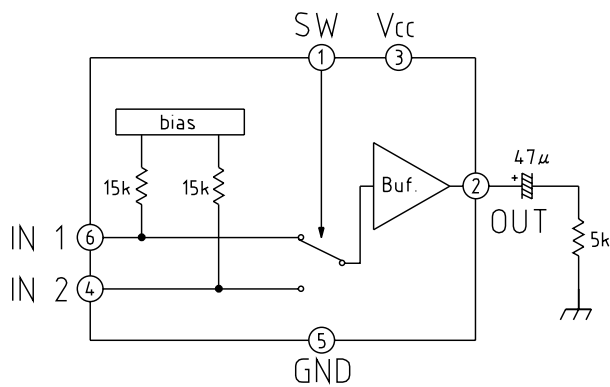

■ MM1505

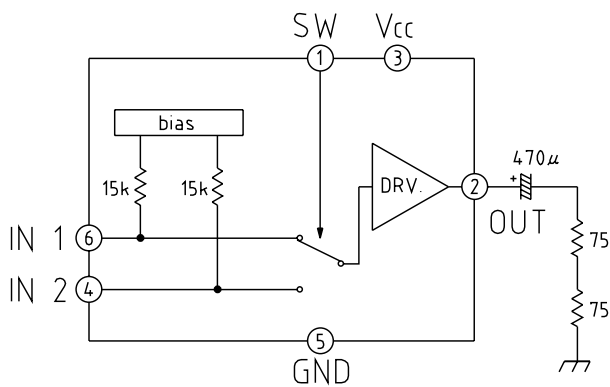

■ MM1511

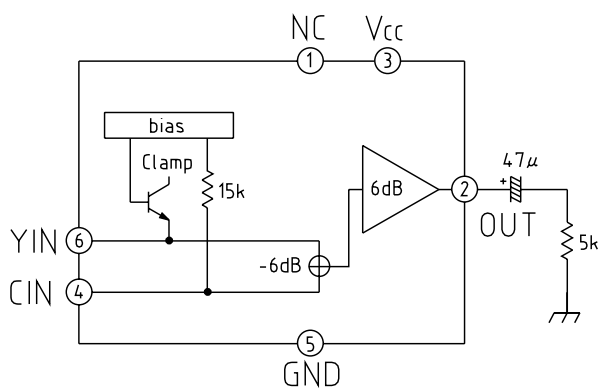



**mitsumi**

Video Switch · 75Ω driver · Y/C mix MM1501

■ MM1511

Item	Symbol	Measurement conditions	Min.	Typ.	Max.	Unit
Consumption current	I <sub>CC</sub>	Refer to measurement procedures		4.4	5.7	mA
Y input pin voltage	V <sub>YIN</sub>	No-signal, no-load	2.00	2.20	2.40	V
C input pin voltage	V <sub>CIN</sub>	No-signal, no-load	1.85	2.05	2.25	V
Output pin voltage	V <sub>OUT</sub>	No-signal, no-load		1.15		V
Voltage gain	G <sub>V</sub>	Refer to measurement procedures	-0.5	0	6.5	dB
Frequency characteristic	f <sub>c</sub>	Refer to measurement procedures	-1	0	+0.5	dB
Differential gain	DG	Refer to measurement procedures	-3	0	+3	%
Differential phase	DP	Refer to measurement procedures	-3	0	+3	deg
Y output dynamic range	V <sub>DY</sub>	Refer to measurement procedures	2.6	2.9		V
C output dynamic range	V <sub>DC</sub>	Refer to measurement procedures	2.0			V
C input impedance	Z <sub>i</sub>			15		kΩ
Output impedance	Z <sub>o</sub>			25		Ω

■ MM1511 ~ MM1512

· Switch Status

Item	Symbol	Switch status	
		S1	S2
Consumption current	I <sub>CC</sub>	2	2
Voltage gain	G <sub>V</sub>	1	2
		2	1
Frequency characteristic	f <sub>c</sub>	1	2
		2	1

Item	Symbol	Switch status	
		S1	S2
Differential gain	DG	3	1
Differential phase	DP	3	1
Y output dynamic range	V <sub>DY</sub>	2	1
C output dynamic range	V <sub>DC</sub>	3	1

· Measurement Procedures

Consumption current	I <sub>CC1</sub>	Connect a DC ammeter to the V <sub>CC</sub> pin and measure. Hereafter, short the ammeter to use.
Voltage gain	G <sub>V</sub>	Input a 2.0V <sub>P-P</sub> (1.0V <sub>P-P</sub> for MM1512), 100kHz sine wave to SG1. If TP1 voltage is V1 and TP2 voltage is V2, find G <sub>V</sub> by the following formula: $G_V = 20\text{LOG} (V_2/V_1) \text{ dB}$
Frequency characteristic	f <sub>c</sub>	In the above G <sub>V</sub> measurement, if TP2 voltage at 10MHz (7MHz for MM1512) is V3, find f <sub>c</sub> by the following formula. $f_c = 20\text{LOG} (V_3/V_2) \text{ dB}$
Differential gain	DG	Input a 2.0V <sub>P-P</sub> (1.0V <sub>P-P</sub> for MM1512) to SG1, input a chroma signal to SG2, and measure differential gain at TP2. APL = 10 ~ 90%
Differential phase	DP	The same as for DG, but measure differential phase.
Y output dynamic range	V <sub>DY</sub>	Input a 100kHz sine wave to SG1. Measure V <sub>DY</sub> , the maximum amplitude under THD 1%, at TP2.
C output dynamic range	V <sub>DC</sub>	Input an APL 50% luminance signal to SG1 and input a chroma signal to SG2. Change the chroma signal amplitude and measure V <sub>DC</sub> , the maximum amplitude where there is no waveform distortion at TP2.



November 1988

Revised November 1999

# 74AC04 • 74ACT04

## Hex Inverter

74ACT04SC : IC52,75,83,84

### General Description

The AC/ACT04 contains six inverters.

### Features

- $I_{CC}$  reduced by 50% on 74AC only
- Outputs source/sink 24 mA
- ACT04 has TTL-compatible inputs

### Ordering Code:

Order Number	Package Number	Package Description
74AC04SC	M14A	14-Lead Small Outline Integrated Circuit (SOIC), JEDEC MS-120, 0.150" Narrow Body
74AC04SJ	M14D	14-Lead Small Outline Package (SOP), EIAJ TYPE II, 5.3mm Wide
74AC04MTC	MTC14	14-Lead Thin Shrink Small Outline Package (TSSOP), JEDEC MO-153, 4.4mm Wide
74AC04PC	N14A	14-Lead Plastic Dual-In-Line Package (PDIP), JEDEC MS-001, 0.300" Wide
74ACT04SC	M14A	14-Lead Small Outline Integrated Circuit (SOIC), JEDEC MS-120, 0.150" Narrow Body
74ACT04MTC	MTC14	14-Lead Thin Shrink Small Outline Package (TSSOP), JEDEC MO-153, 4.4mm Wide
74ACT04PC	N14A	14-Lead Plastic Dual-In-Line Package (PDIP), JEDEC MS-001, 0.300" Wide

Device also available in Tape and Reel. Specify by appending suffix letter "X" to the ordering code. (PC not available in Tape and Reel.)

### Logic Symbol

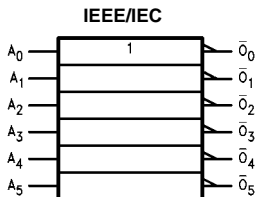

### Connection Diagram

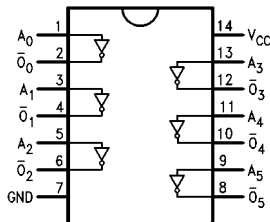

### Pin Descriptions

Pin Names	Description
$A_n$	Inputs
$\bar{O}_n$	Outputs

■ PIN ASSIGNMENT (74HCU04AFN : IC71,72,76)

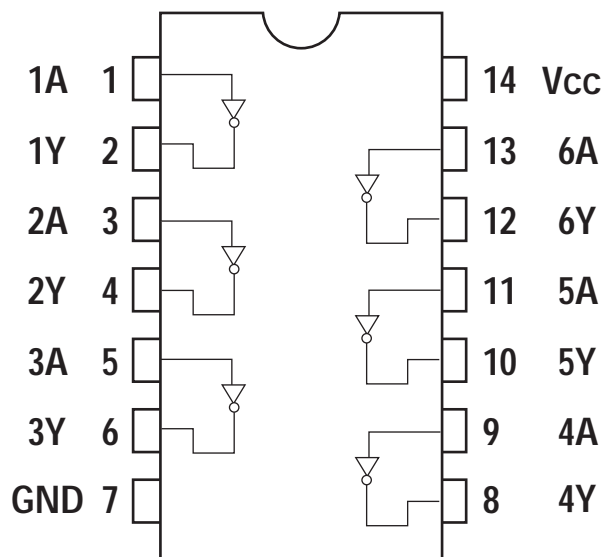

■ LOGIC SYMBOL

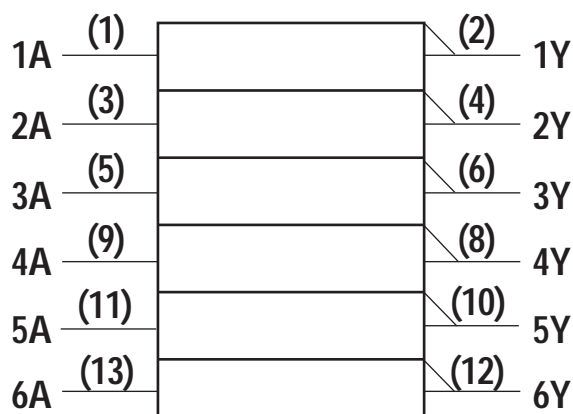

■ TRUTH TABLE

A	Y
L	H
H	L

**DIR IC PIN ASSIGNMENT & BLOCK DIAGRAM**  
**PIN ASSIGNMENT (TOP VIEW) : IC73**

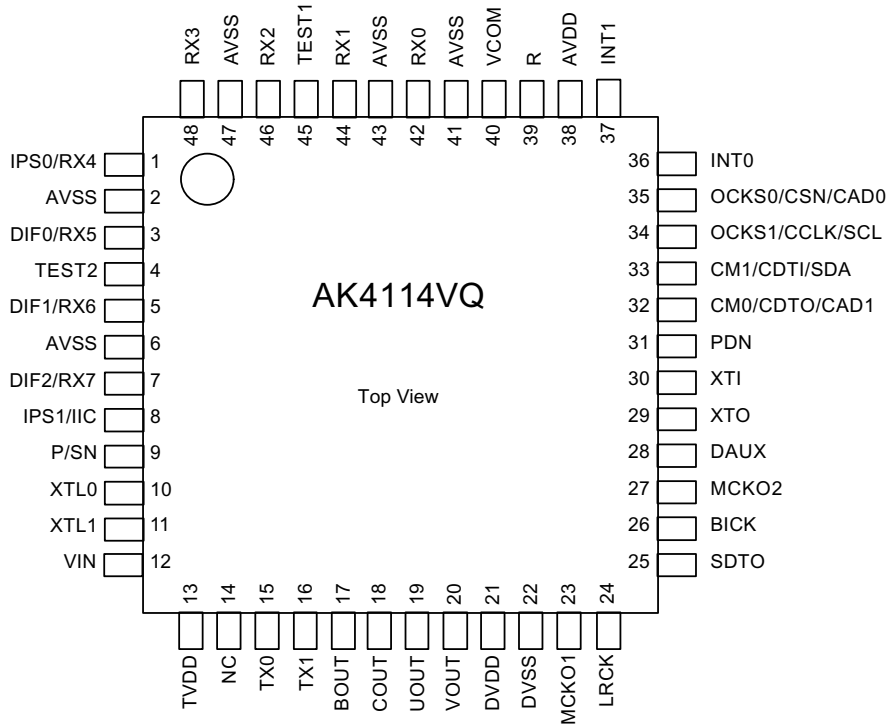



<b>DIR IC PIN FUNCTION (AK4114VQ) : IC73</b>
--

PIN/FUNCTION			
No.	Pin Name	I/O	Function
1	IPS0	I	Input Channel Select 0 Pin in Parallel Mode
	RX4	I	Receiver Channel 4 Pin in Serial Mode (Internal biased pin)
2	NC(AVSS)	I	No Connect No internal bonding. This pin should be connected to AVSS.
3	DIF0	I	Audio Data Interface Format 0 Pin in Parallel Mode
	RX5	I	Receiver Channel 5 Pin in Serial Mode (Internal biased pin)
4	TEST2	I	TEST 2 pin This pin should be connect to AVSS.
5	DIF1	I	Audio Data Interface Format 1 Pin in Parallel Mode
	RX6	I	Receiver Channel 6 Pin in Serial Mode (Internal biased pin)
6	NC(AVSS)	I	No Connect No internal bonding. This pin should be connected to AVSS.
7	DIF2	I	Audio Data Interface Format 2 Pin in Parallel Mode
	RX7	I	Receiver Channel 7 Pin in Serial Mode (Internal biased pin)
8	IPS1	I	Input Channel Select 1 Pin in Parallel Mode
	IIC	I	IIC Select Pin in Serial Mode. “L”: 4-wire Serial, “H”: IIC
9	P/SN	I	Parallel/Serial Select Pin “L”: Serial Mode, “H”: Parallel Mode
10	XTL0	I	X'tal Frequency Select 0 Pin
11	XTL1	I	X'tal Frequency Select 1 Pin
12	VIN	I	V-bit Input Pin for Transmitter Output
13	TVDD	I	Input Buffer Power Supply Pin, 3.3V or 5V
14	NC	I	No Connect No internal bonding. This pin should be open or connected to DVSS.
15	TX0	O	Transmit Channel (Through Data) Output 0 Pin
16	TX1	O	When TX bit = “0”, Transmit Channel (Through Data) Output 1 Pin. When TX bit = “1”, Transmit Channel (DAUX Data) Output Pin (Default).
17	BOUT	O	Block-Start Output Pin for Receiver Input “H” during first 40 frames.
18	COUT	O	C-bit Output Pin for Receiver Input
19	UOUT	O	U-bit Output Pin for Receiver Input
20	VOUT	O	V-bit Output Pin for Receiver Input
21	DVDD	I	Digital Power Supply Pin, 3.3V
22	DVSS	I	Digital Ground Pin
23	MCKO1	O	Master Clock Output 1 Pin
24	LRCK	I/O	Channel Clock Pin
25	SDTO	O	Audio Serial Data Output Pin
26	BICK	I/O	Audio Serial Data Clock Pin
27	MCKO2	O	Master Clock Output 2 Pin
28	DAUX	I	Auxiliary Audio Data Input Pin
29	XTO	O	X'tal Output Pin
30	XTI	I	X'tal Input Pin

## DIR IC PIN FUNCTION (AK4114VQ) : IC73

PIN/FUNCTION (Continued)			
No.	Pin Name	I/O	Function
31	PDN	I	Power-Down Mode Pin When "L", the AK4114 is powered-down and reset.
32	CM0	I	Master Clock Operation Mode 0 Pin in Parallel Mode
	CDTO	O	Control Data Output Pin in Serial Mode, IIC= "L".
	CAD1	I	Chip Address 1 Pin in Serial Mode, IIC= "H".
33	CM1	I	Master Clock Operation Mode 1 Pin in Parallel Mode
	CDTI	I	Control Data Input Pin in Serial Mode, IIC= "L".
	SDA	I/O	Control Data Pin in Serial Mode, IIC= "H".
34	OCKS1	I	Output Clock Select 1 Pin in Parallel Mode
	CCLK	I	Control Data Clock Pin in Serial Mode, IIC= "L"
	SCL	I	Control Data Clock Pin in Serial Mode, IIC= "H"
35	OVSS0	I	Output Clock Select 0 Pin in Parallel Mode
	CSN	I	Chip Select Pin in Serial Mode, IIC="L".
	CAD0	I	Chip Address 0 Pin in Serial Mode, IIC= "H".
36	INT0	O	Interrupt 0 Pin
37	INT1	O	Interrupt 1 Pin
38	AVDD	I	Analog Power Supply Pin, 3.3V
39	R	-	External Resistor Pin 18k $\Omega$ +/-1% resistor should be connected to AVSS externally.
40	VCOM	-	Common Voltage Output Pin 0.47 $\mu$ F capacitor should be connected to AVSS externally.
41	AVSS	I	Analog Ground Pin
42	RX0	I	Receiver Channel 0 Pin (Internal biased pin) This channel is default in serial mode.
43	NC(AVSS)	I	No Connect No internal bonding. This pin should be connected to AVSS.
44	RX1	I	Receiver Channel 1 Pin (Internal biased pin)
45	TEST1	I	TEST 1 pin. This pin should be connected to AVSS.
46	RX2	I	Receiver Channel 2 Pin (Internal biased pin)
47	NC(AVSS)	I	No Connect No internal bonding. This pin should be connected to AVSS.
48	RX3	I	Receiver Channel 3 Pin (Internal biased pin)

Note 1. All input pins except internal biased pins should not be left floating.



March 1995  
Revised February 2005

## 74LCX32

### Low Voltage Quad 2-Input OR Gate with 5V Tolerant Inputs

#### General Description

The LCX32 contains four 2-input OR gates. The inputs tolerate voltages up to 7V allowing the interface of 5V systems to 3V systems.

The 74LCX32 is fabricated with advanced CMOS technology to achieve high speed operation while maintaining CMOS low power dissipation.

#### Features

- 5V tolerant inputs
- 2.3V–3.6V  $V_{CC}$  specifications provided
- 5.5 ns  $t_{PD}$  max ( $V_{CC} = 3.3V$ ), 10  $\mu A$   $I_{CC}$  max
- Power down high impedance inputs and outputs
- $\pm 24$  mA output drive ( $V_{CC} = 3.0V$ )
- Implements patented noise/EMI reduction circuitry
- Latch-up performance exceeds JEDEC 78 conditions
- ESD performance:
  - Human body model > 2000V
  - Machine model > 150V
- Leadless Pb-Free DQFN package

#### Ordering Code:

Order Number	Package Number	Package Description
74LCX32M	M14A	14-Lead Small Outline Integrated Circuit (SOIC), JEDEC MS-012, 0.150" Narrow
74LCX32MX_NL (Note 2)	M14A	Pb-Free 14-Lead Small Outline Integrated Circuit (SOIC), JEDEC MS-012, 0.150" Narrow
74LCX32SJ	M14D	Pb-Free 14-Lead Small Outline Package (SOP), EIAJ TYPE II, 5.3mm Wide
74LCX32BQX (Note 1)	MLP014A	Pb-Free 14-Terminal Depopulated Quad Very-Thin Flat Pack No Leads (DQFN), JEDEC MO-241, 2.5 x 3.0mm
74LCX32MTC	MTC14	14-Lead Thin Shrink Small Outline Package (TSSOP), JEDEC MO-153, 4.4mm Wide
74LCX32MTCX_NL (Note 2)	MTC14	Pb-Free 14-Lead Thin Shrink Small Outline Package (TSSOP), JEDEC MO-153, 4.4mm Wide

Devices also available in Tape and Reel. Specify by appending the suffix letter "X" to the ordering code.

Pb-Free package per JEDEC J-STD-020B.

**Note 1:** DQFN package available in Tape and Reel only.

**Note 2:** "\_NL" indicates Pb-Free package (per JEDEC J-STD-020B). Device available in Tape and Reel only.



### Logic Symbol

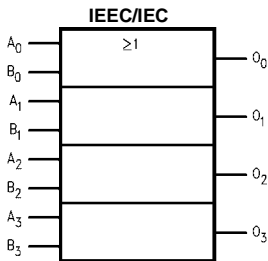

### Pin Descriptions

Pin Names	Description
A <sub>n</sub> , B <sub>n</sub>	Inputs
O <sub>n</sub>	Outputs

### Connection Diagrams

Pin Assignments for SOIC, SOP, and TSSOP

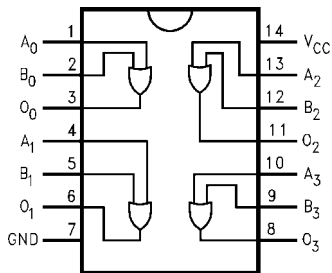

Pad Assignment for DQFN

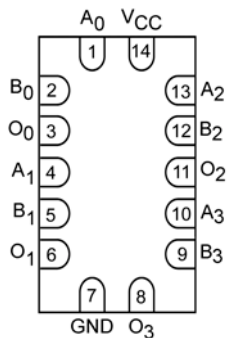

(Top View)



### GENERAL DESCRIPTION

The AK4589 is a single chip CODEC that includes two channels of ADC and eight channels of DAC. The ADC outputs 24bit data and the DAC accepts up to 24bit input data. The ADC has the Enhanced Dual Bit architecture with wide dynamic range. The DAC introduces the new developed Advanced Multi-Bit architecture, and achieves wider dynamic range and lower outband noise. The AK4589 has a dynamic range of 102dB for ADC, 114dB for DAC and is well suited for digital surround for home theater audio. The AK4589 also has the balance volume control corresponding to the Dolby Digital (AC-3) system.

The also has digital audio receiver (DIR) and transmitter (DIT) compatible with 192kHz, 24bits. The DIR has 8-channel input selector and can automatically detect a Non-PCM bit stream. The AK4589 provides a compatibility of hardware and software with the AK4588.

\*Dolby Digital (AC-3) is a trademark of Dolby Laboratories.

### FEATURES

- ADC/DAC part
  - 2ch 24bit ADC
    - 64x Oversampling
    - Sampling Rate up to 96kHz
    - Linear Phase Digital Anti-Alias Filter
    - Single-Ended Input
    - S/(N+D): 92dB
    - Dynamic Range, S/N: 102dB
    - Digital HPF for offset cancellation
    - Overflow flag
  - 8ch 24bit DAC
    - 128x Oversampling
    - Sampling Rate up to 192kHz
    - 24bit 8 times Digital Filter
    - Differential Outputs
    - On-chip Switched-Capacitor Filter
    - S/(N+D): 94dB
    - Dynamic Range, S/N: 114dB
    - Individual channel digital volume with 128 levels and 0.5dB step
    - Soft mute
    - De-emphasis for 32kHz, 44.1kHz, 48kHz
    - Zero Detect Function
  - High Jitter Tolerance
  - External Master Clock Input:
    - 256fs, 384fs, 512fs (fs=32kHz ~ 48kHz)
    - 128fs, 192fs, 256fs (fs=64kHz ~ 96kHz)
    - 128fs (fs=120kHz ~ 192kHz)

- DIR/DIT Part
  - AES3, IEC60958, S/PDIF, EIAJ CP1201 Compatible
  - Low jitter Analog PLL
  - PLL Lock Range : 32kHz to 192kHz
  - Clock Source: PLL or X'tal
  - 8-channel Receiver input
  - 2-channel Transmission output (Through output or DIT)
  - Auxiliary digital input
  - De-emphasis for 32kHz, 44.1kHz, 48kHz and 96kHz
  - Detection Functions
    - Non-PCM Bit Stream Detection
    - DTS-CD Bit Stream Detection
    - Sampling Frequency Detection  
(32kHz, 44.1kHz, 48kHz, 88.2kHz, 96kHz, 176.4kHz, 192kHz)
    - Unlock & Parity Error Detection
    - Validity Flag Detection
  - Up to 24bit Audio Data Format
  - Audio I/F: Master or Slave Mode
  - 40-bit Channel Status Buffer
  - Burst Preamble bit Pc and Pd Buffer for Non-PCM bit stream
  - Q-subcode Buffer for CD bit stream
  - Serial  $\mu$ P I/F
  - Two Master Clock Outputs: 64fs/128fs/256fs/512fs
- TTL Level Digital I/F
- 4-wire Serial and I<sup>2</sup>C Bus  $\mu$ P I/F for mode setting
- Operating Voltage: 4.75 to 5.25V with 5V tolerance
- Power Supply for output buffer: 2.7 to 5.25V
- 80pin LQFP Package (0.5mm pitch)
- AK4588 compatible w/o analog outputs

■ Block Diagram

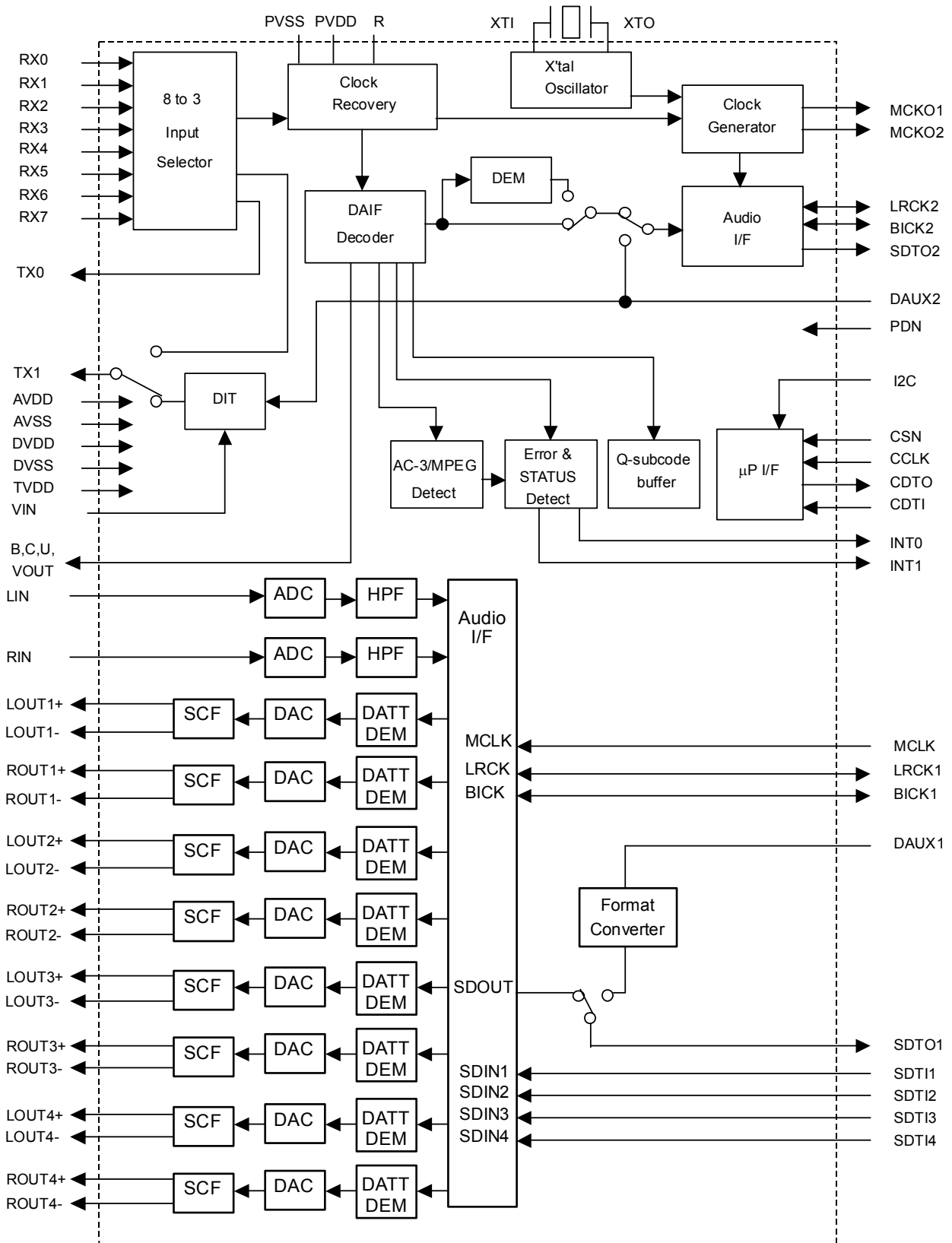

ASAHI KASEI

[AK4589]

■ Ordering Guide

AK4589VQ    -10 ~ +70°C    80pin LQFP(0.5mm pitch)  
 AKD4589    Evaluation Board for AK4589

■ Pin Layout

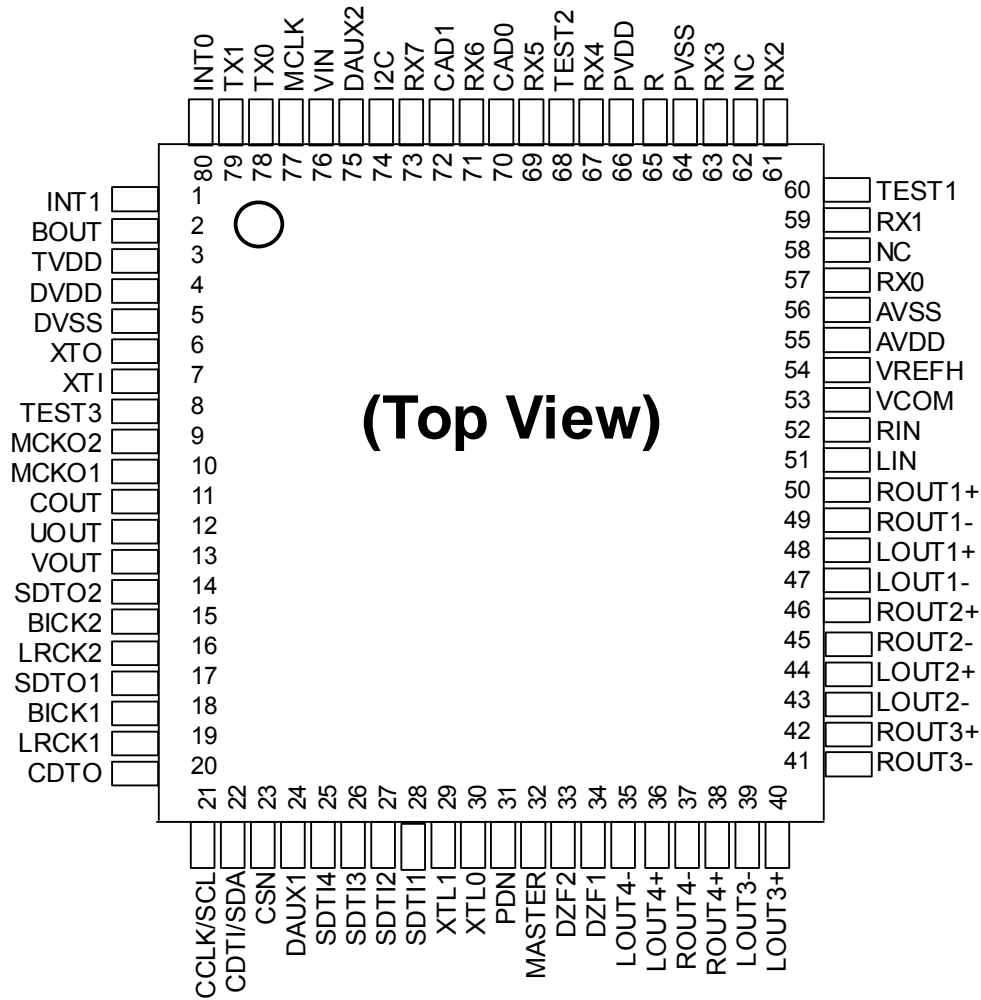

PIN/FUNCTION			
No.	Pin Name	I/O	Function
1	INT1	O	Interrupt 1 Pin
2	BOUT	O	Block-Start Output Pin for Receiver Input "H" during first 40 flames.
3	TVDD	-	Output Buffer Power Supply Pin, 2.7V~5.25V
4	DVDD	-	Digital Power Supply Pin, 4.75V~5.25V
5	DVSS	-	Digital Ground Pin
6	XTO	O	X'tal Output Pin
7	XTI	I	X'tal Input Pin
8	TEST3	I	Test 3 Pin This pin should be connected to DVSS.
9	MCKO2	O	Master Clock Output 2 Pin
10	MCKO1	O	Master Clock Output 1 Pin
11	COOUT	O	C-bit Output Pin for Receiver Input
12	UOUT	O	U-bit Output Pin for Receiver Input
13	VOOUT	O	V-bit Output Pin for Receiver Input
14	SDTO2	O	Audio Serial Data Output Pin (DIR/DIT part)
15	BICK2	I/O	Audio Serial Data Clock Pin (DIR/DIT part)
16	LRCK2	I/O	Channel Clock Pin (DIR/DIT part)
17	SDTO1	O	Audio Serial Data Output Pin (ADC/DAC part)
18	BICK1	I/O	Audio Serial Data Clock Pin (ADC/DAC part)
19	LRCK1	I/O	Input Channel Clock Pin
20	CDTO	O	Control Data Output Pin in Serial Mode, I2C= "L".
21	CCLK	I	Control Data Clock Pin in Serial Mode, I2C= "L"
	SCL	I	Control Data Clock Pin in Serial Mode, I2C= "H"
22	CDTI	I	Control Data Input Pin in Serial Mode, I2C= "L".
	SDA	I/O	Control Data Pin in Serial Mode, I2C= "H".
23	CSN	I	Chip Select Pin in Serial Mode, I2C= "L".
		I	This pin should be connected to DVSS, I2C= "H".
24	DAUX1	I	AUX Audio Serial Data Input Pin (ADC/DAC part)
25	SDTI4	I	DAC4 Audio Serial Data Input Pin
26	SDTI3	I	DAC3 Audio Serial Data Input Pin
27	SDTI2	I	DAC2 Audio Serial Data Input Pin
28	SDTI1	I	DAC1 Audio Serial Data Input Pin
29	XTL1	I	X'tal Frequency Select 0 Pin
30	XTL0	I	X'tal Frequency Select 1 Pin

No.	Pin Name	I/O	Function	
31	PDN	I	Power-Down Mode Pin When "L", the AK4589 is powered-down, all digital output pins go "L", all registers are reset. When CAD1/0 pins are changed, the AK4589 should be reset by PDN pin.	
32	MASTER	I	Master Mode Select Pin "H": Master mode, "L": Slave mode	
33	DZF2	O	Zero Input Detect 2 Pin (Table 13) When the input data of the group 1 follow total 8192 LRCK cycles with "0" input data, this pin goes to "H". And when RSTN bit is "0", PWDAN bit is "0", this pin goes to "H". It always is in "L" when P/S pin is "H".	
	OVF	O	Analog Input Overflow Detect Pin This pin goes to "H" if the analog input of Lch or Rch overflows.	
34	DZF1	O	Zero Input Detect 1 Pin (Table 13) When the input data of the group 1 follow total 8192 LRCK cycles with "0" input data, this pin goes to "H". And when RSTN bit is "0", PWDAN bit is "0", this pin goes to "H". Output is selected by setting DZFE pin when P/S pin is "H".	
35	LOUT4-	O	DAC4 Lch Negative Analog Output Pin	470pF capacitor should be connected between LOUT4- and LOUT4+.
36	LOUT4+	O	DAC4 Lch Positive Analog Output Pin	
37	ROUT4-	O	DAC4 Rch Negative Analog Output Pin	470pF capacitor should be connected between ROUT4- and ROUT4+.
38	ROUT4+	O	DAC4 Rch Positive Analog Output Pin	
39	LOUT3-	O	DAC3 Lch Negative Analog Output Pin	470pF capacitor should be connected between LOUT3- and LOUT3+.
40	LOUT3+	O	DAC3 Lch Positive Analog Output Pin	
41	ROUT3-	O	DAC3 Rch Negative Analog Output Pin	470pF capacitor should be connected between ROUT3- and ROUT3+.
42	ROUT3+	O	DAC3 Rch Positive Analog Output Pin	
43	LOUT2-	O	DAC2 Lch Negative Analog Output Pin	470pF capacitor should be connected between LOUT2- and LOUT2+.
44	LOUT2+	O	DAC2 Lch Positive Analog Output Pin	
45	ROUT2-	O	DAC2 Rch Negative Analog Output Pin	470pF capacitor should be connected between ROUT2- and ROUT2+.
46	ROUT2+	O	DAC2 Rch Positive Analog Output Pin	
47	LOUT1-	O	DAC1 Lch Negative Analog Output Pin	470pF capacitor should be connected between LOUT1- and LOUT1+.
48	LOUT1+	O	DAC1 Lch Positive Analog Output Pin	
49	ROUT1-	O	DAC1 Rch Negative Analog Output Pin	470pF capacitor should be connected between ROUT1- and ROUT1+.
50	ROUT1+	O	DAC1 Rch Positive Analog Output Pin	
51	LIN	I	Lch Analog Input Pin	
52	RIN	I	Rch Analog Input Pin	
53	VCOM	-	Common Voltage Output Pin 2.2μF capacitor should be connected to AVSS externally.	
54	VREFH	-	Positive Voltage Reference Input Pin, AVDD	

No.	Pin Name	I/O	Function
55	AVDD	-	Analog Power Supply Pin, 4.75V~5.25V
56	AVSS	-	Analog Ground Pin, 0V
57	RX0	I	Receiver Channel 0 Pin (Internal biased pin. Internally biased at PVDD/2)
58	NC	-	No Connect pin No internal bonding. This pin should be connected to PVSS.
59	RX1	I	Receiver Channel 1 Pin (Internal biased pin. Internally biased at PVDD/2)
60	TEST1	I	Test 1 Pin This pin should be connected to PVSS.
61	RX2	I	Receiver Channel 2 Pin (Internal biased pin. Internally biased at PVDD/2)
62	NC	-	No Connect pin No internal bonding. This pin should be connected to PVSS.
63	RX3	I	Receiver Channel 3 Pin (Internal biased pin. Internally biased at PVDD/2)
64	PVSS	-	PLL Ground pin
65	R	-	External Resistor Pin 12k $\Omega$ +/-1% resistor should be connected to PVSS externally.
66	PVDD	-	PLL Power supply Pin, 4.75V~5.25V
67	RX4	I	Receiver Channel 4 Pin (Internal biased pin. Internally biased at PVDD/2)
68	TEST2	I	Test 2 Pin This pin should be connected to PVSS.
69	RX5	I	Receiver Channel 5 Pin (Internal biased pin. Internally biased at PVDD/2)
70	CAD0	I	Chip Address 0 Pin (ADC/DAC part)
71	RX6	I	Receiver Channel 6 Pin (Internal biased pin. Internally biased at PVDD/2)
72	CAD1	I	Chip Address 1 Pin (ADC/DAC part)
73	RX7	I	Receiver Channel 7 Pin (Internal biased pin. Internally biased at PVDD/2)
74	I2C	I	Control Mode Select Pin. “L”: 4-wire Serial, “H”: I <sup>2</sup> C Bus
75	DAUX2	I	Auxiliary Audio Data Input Pin (DIR/DIT part)
76	VIN	I	V-bit Input Pin for Transmitter Output
77	MCLK	I	Master Clock Input Pin
78	TX0	O	Transmit Channel (Through Data) Output 0 Pin
79	TX1	O	Transmit Channel Output1 pin When DIT bit = “0”, Through Data. When DIT bit = “1”, DAUX2 Data.
80	INT0	O	Interrupt 0 Pin

Note: All input pins except internal biased pins and Analog input pins (RX0-7, LIN, RIN) should not be left floating.

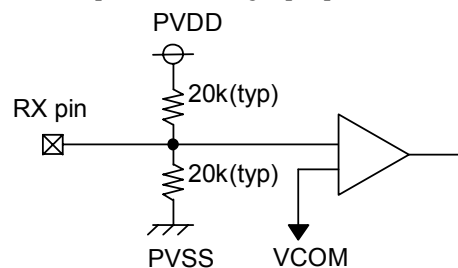

Internal biased pin Circuit

### ■ Handling of Unused Pin

The unused I/O pins should be processed appropriately as below.

Classification	Pin Name	Setting
Analog	RX0-7, LOUT1-4, ROUT1-4, LIN, RIN	These pins should be open.
Digital	INT0-1, BOUT, XTO, MCKO1-2, COUT, UOUT, VOUT, SDTO1-2, CDTO, DZF1-2, TX1-0	These pins should be open.
	CSN, DAUX1-2, SDTI1-4, XTL0-1	These pins should be connected to DVSS.
	TEST1-3	These pins should be connected to PVSS.



	= Preliminary =	<b>AK5381</b> <b>24Bit 96kHz <math>\Delta\Sigma</math> ADC</b>
---	-----------------	---

### GENERAL DESCRIPTION

The AK5381 is a stereo A/D Converter with wide sampling rate of 4kHz ~ 96kHz and is suitable for High-end audio system. The AK5381 achieves high accuracy and low cost by using Enhanced dual bit  $\Delta\Sigma$  techniques. The AK5381 requires no external components because the analog inputs are single-ended. The audio interface has two formats (MSB justified,  $I^2S$ ) and can correspond to many systems like music instrument and AV receiver.

### FEATURES

- Stereo  $\Delta\Sigma$  ADC
- On-Chip Digital Anti-Alias Filtering
- Single-ended Input
- Digital HPF for DC-Offset cancel
- S/(N+D): 96dB@5V for 48kHz
- DR: 106dB@5V for 48kHz
- S/N: 106dB@5V for 48kHz
- Sampling Rate Ranging from 4kHz to 96kHz
- Master Clock:
  - 256fs/384fs/512fs/768fs (~ 48kHz)
  - 256fs/384fs (~ 96kHz)
- Audio Interface: Master or Slave Mode selectable
- Input level: TTL/CMOS selectable
- Output format: 24bit MSB justified /  $I^2S$  selectable
- Power Supply: 4.5 ~ 5.5V (VA)
  - 2.7 ~ 5.5V (VD at 48kHz)
  - 3.0 ~ 5.5V (VD at 96kHz)
- Ta = -40 ~ 85°C
- Small 16pin TSSOP Package
- AK5380 Pin-compatible

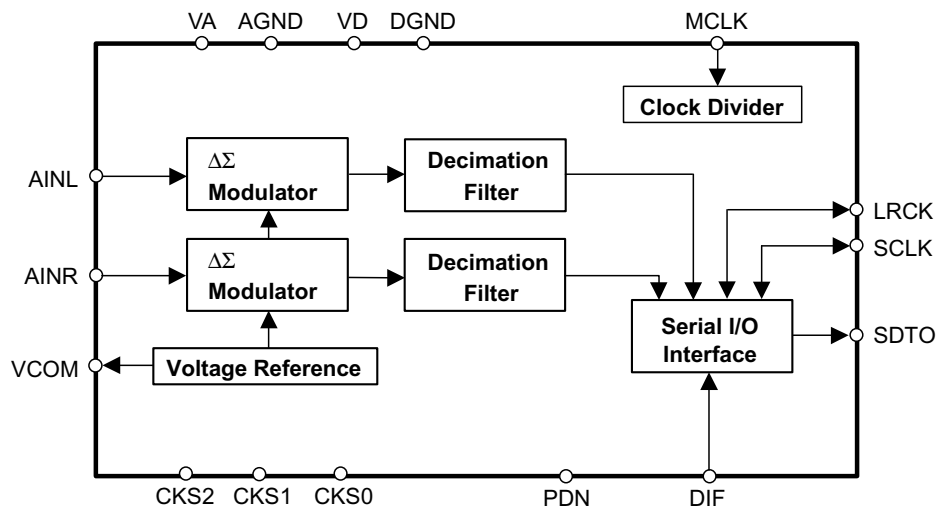

ASAHI KASEI

**AKM CONFIDENTIAL**

[AK5381]

■ **Ordering Guide**

AK5381VT  
AKD5381

-40 ~ +85°C  
Evaluation Board for AK5381

16pin TSSOP (0.65mm pitch)

■ **Pin Layout**

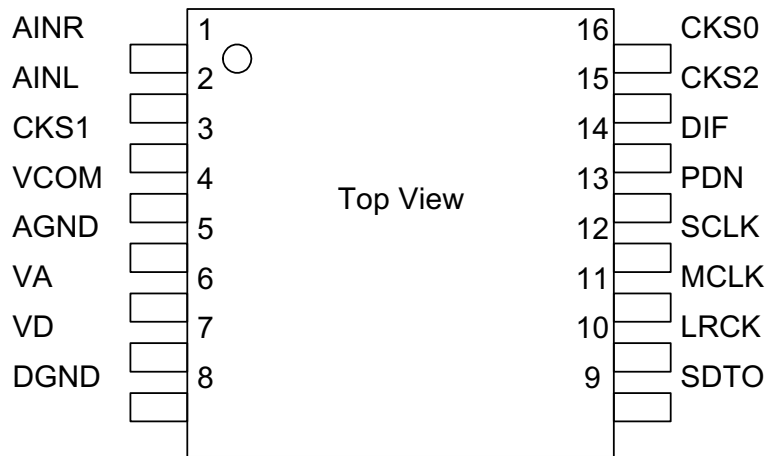

■ **Compatibility with AK5380**

	AK5380	AK5381
Master Mode	Not Available	Available
HPF OFF	Not Available	Available
VD (Digital Supply)	4.5 to 5.5V@fs=96kHz	3.0 to 5.5V@fs=96kHz
Pin #3	NC	CKS1
Pin #15	TTL	CKS2
Pin #16	TST	CKS0

<b>PIN / FUNCTION</b>
-----------------------

No.	Pin Name	I/O	Function
1	AINR	I	Rch Analog Input Pin
2	AINL	I	Lch Analog Input Pin
3	CKS1	I	Mode Select 1 Pin
4	VCOM	O	Common Voltage Output Pin, VA/2 Bias voltage of ADC input.
5	AGND	-	Analog Ground Pin
6	VA	-	Analog Power Supply Pin, 4.5 ~ 5.5V
7	VD	-	Digital Power Supply Pin, 2.7 ~ 5.5V(fs=4k ~ 48kHz), 3.0 ~ 5.5V(fs=48k ~ 96kHz)
8	DGND	-	Digital Ground Pin
9	SDTO	O	Audio Serial Data Output Pin “L” Output at Power-down mode.
10	LRCK	I/O	Output Channel Clock Pin “L” Output in Master Mode at Power-down mode.
11	MCLK	I	Master Clock Input Pin
12	SCLK	I/O	Audio Serial Data Clock Pin “L” Output in Master Mode at Power-down mode.
13	PDN	I	Power Down Mode Pin “H”: Power up, “L”: Power down
14	DIF	I	Audio Interface Format Pin “H” : 24bit I <sup>2</sup> S Compatible, “L” : 24bit MSB justified
15	CKS2	I	Mode Select 2 Pin
16	CKS0	I	Mode Select 0 Pin

Note: All digital input pins should not be left floating.

**■ PIN ASSIGNMENT.(CS493263)**

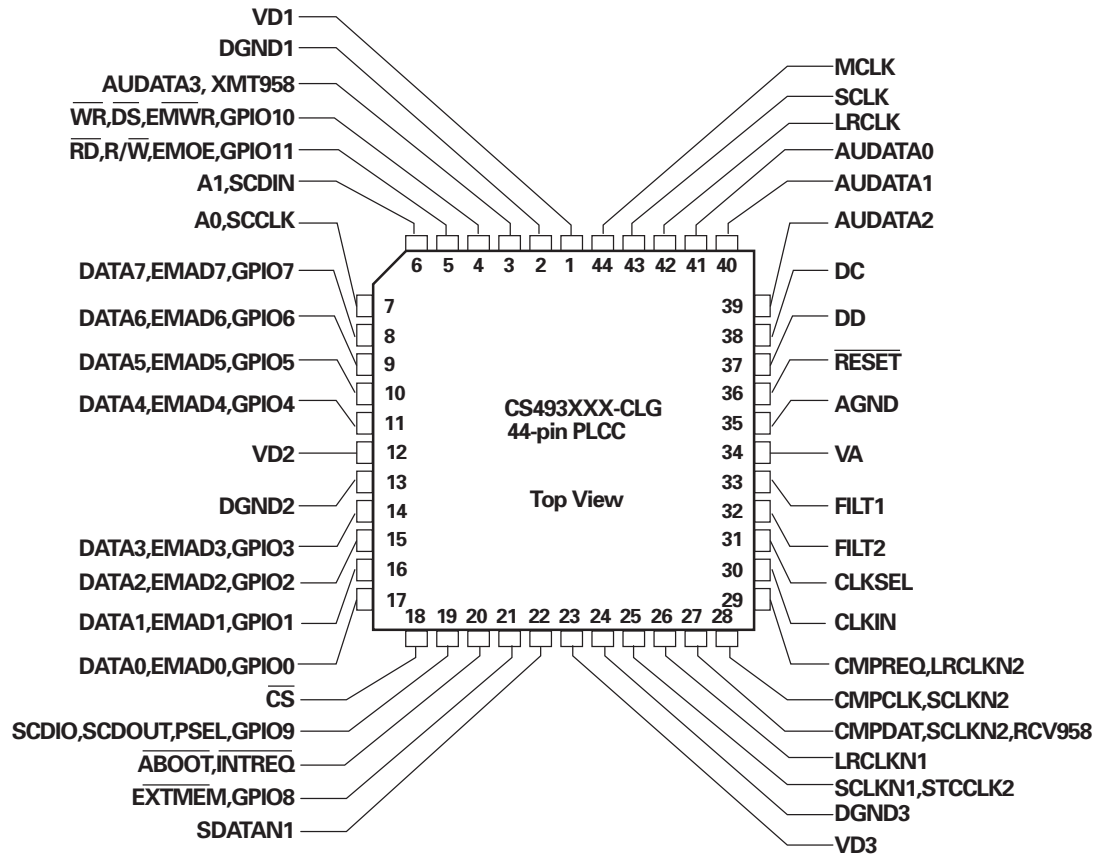

**(TOP VIEW)**

**BLOCK DIAGRAM(CS493263)**

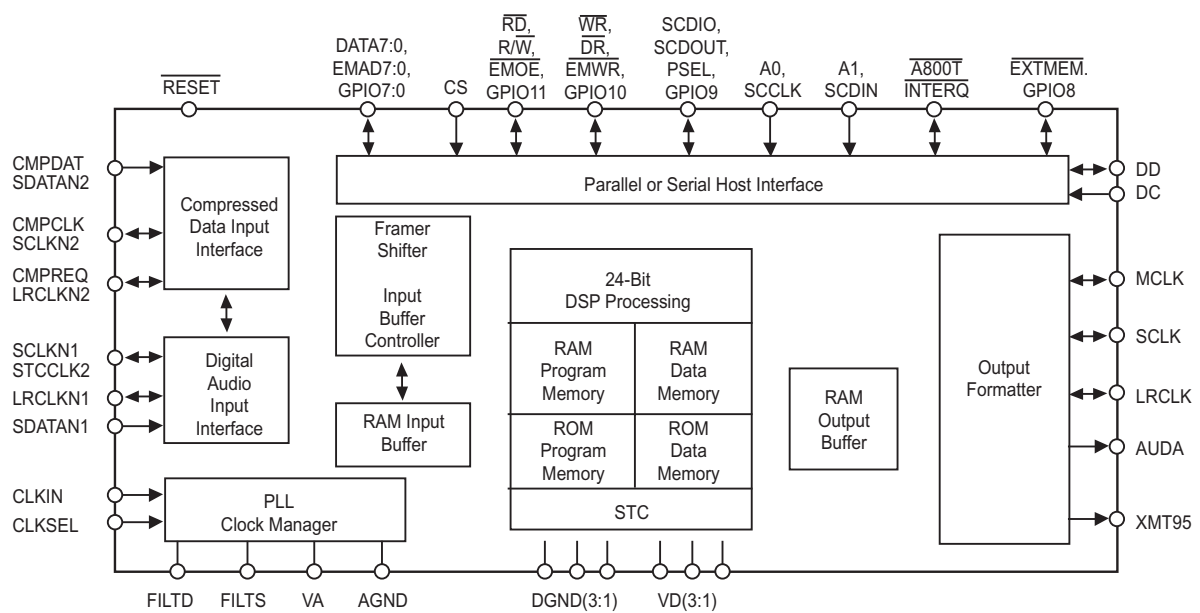

## AUDIO DSP (CS493263 - CLG : IC75)

PIN No.	Pin Name	I/O	Function
1,12,23	+VD1	-	Digital Power supply. Normally +2.5v
2,13,24	DGND	-	Digital Ground
3	AUD3	O	SPDIF transmitter output/Digital audio output(N.C)
4	WR	I	Host write strobe pin(connected to GND with an external resistor)
5	RD	I	Host parallel output enable pin(pulled up with an external resistor)
6	CS_DA	I	SPI Serial data input pin
7	CS_CK	I	Serial control clock input pin
8	EMAD7	I/O	Serial data IN/OUTPUT pins(pulled up with an external resistor)
9	EMAD6	I/O	
10	EMAD5	I/O	
11	EMAD4	I/O	
14	EMAD3	I/O	
15	EMAD2	I/O	
16	EMAD1	I/O	
17	EMAD0	I/O	
18	CS_CE	I	Host parallel chip select pin
19	SCDIO(AK_DOUT)	O	Serial control port data ouput pin
20	INTREQ	O	Control port interrupt request output pin
21	EXTMEM	I/O	External Memory Chip Selector(pulled up with an external resistor)
22	SDATAN1(SDI)	I	PCM audio data input number 1 pin
25	SCLKN1(BICK)	I	PCM audio input bit clock pin
26	LRCLKN1(LRCK)	I	PCM audio input sample rate clock pin
27	CMPDAT(SDI)	I	PCM audio data input number 2 pin
28	CMPCLK(BICK)	I	PCM audio input bit clock pin
29	CREQ(LRCK)	I	PCM audio input sample rate clock pin
30	CLKIN(XIN)	I	Master clock input(used external clock)
31	CLKSEL(GND)	I	DSP clock mode select pin: connect the GND
32	FILT1		Connects to an external filter for the on-chip phase-locked loop
33	FILT1		Connects to an external filter for the on-chip phase-locked loop
34	+2.5V	-	Analog Power supply for clock generator . Normally +2.5V
35	AGND	-	Analog ground supply for clock generator PLL.
36	RESET(CS_RST)	I	Master reset input pin
37	DBDATA	-	Reserved pin and should be pulled up with an external resistor.
38	DBCLK	-	Reserved pin and should be pulled up with an external resistor.
39	AUD2(SDO2)	O	PCM multi-format digital-audio data ouput2 pin
40	AUD1(SDO1)	O	PCM multi-format digital-audio data ouput1 pin
41	AUD0(SDO0)	O	PCM multi-format digital-audio data ouput0 pin
42	LRCLK	I	Audio output sample rate clock pin
43	SCLK(BICK)	I	Audio ouput bit clock pin
44	MCLK	I	Audio master clock output pin



# CS49400 Family DSP

## Multi-Standard Audio Decoder

### Features

- CS49300 Legacy Audio Decoder Support
- Dolby Digital EX™, Dolby Pro Logic II™
- DTS-ES 96/24™, DTS 96/24™, DTS-ES Discrete 6.1™, DTS-ES Matrix 6.1™, DTS Digital Surround™ and DTS Virtual 5.1™
- MPEG-2: AAC Multichannel 5.1
- MPEG Multichannel and Musicam
- MPEG-1/2, Layer III (MP3)
- DTS Neo:6™, LOGIC7®, SRS Circle Surround II™
- Cirrus Extra Surround™, Cirrus Original Surround 6.1 (C.O.S. 6.1)™
- THX Surround EX™, THX Ultra2 Cinema™
- 12-Channel Serial Audio Inputs
- Integrated 8K Byte Input Buffer
- Powerful 32-bit Audio DSP
- Customer Software Security Keys
- Large On-chip X, Y, and Program RAM
- Supports SDRAM, SRAM, FLASH memories
- 16-channel PCM output
- Dual S/PDIF Transmitters
- SPI Serial, and Motorola® and Intel® Parallel Host Control Interfaces
- GPIO support for all common sub-circuits

### Description

The CS49400 Audio Decoder DSP is targeted as a market-specific consumer entertainment processor for AV Receivers and DVD Audio/Video Players. The device is constructed using an enhanced version of the CS49300 Family DSP audio decoder followed by a 32-bit programmable post-processor DSP, which gives the designer the ability to add product differentiation through the Cirrus Framework™ programming structure and Framework module library. Dolby Digital Pro Logic II, DTS Digital Surround, MPEG Multichannel, and Cirrus Original Surround 6.1 PCM Effects Processor (capable of generating such DSP audio modes as: Hall, Theater, Church) are included in the cost of the CS49400 Family DSP. Additional algorithms available through the Crystal Ware™ Software Licensing Program, give the designer the ability to further deliver end-product differentiation.

The CS49400 contains sufficient on-chip SRAM to support decoding all major audio decoding algorithms available today including: AAC Multichannel, DTS 96/24, DTS-ES 96/24. The CS49400 also supports a glueless SDRAM/SRAM for increased all-channel delays. The SRAM interface also supports connection to an external byte-wide EPROM for code storage or Flash memory thus allowing products to be field-upgradable as new audio algorithms are developed.

This chip, teamed with Crystal Ware™ certified decoder library, Cirrus digital interface products and mixed signal data converters, enables the conception and design of next generation digital entertainment products.

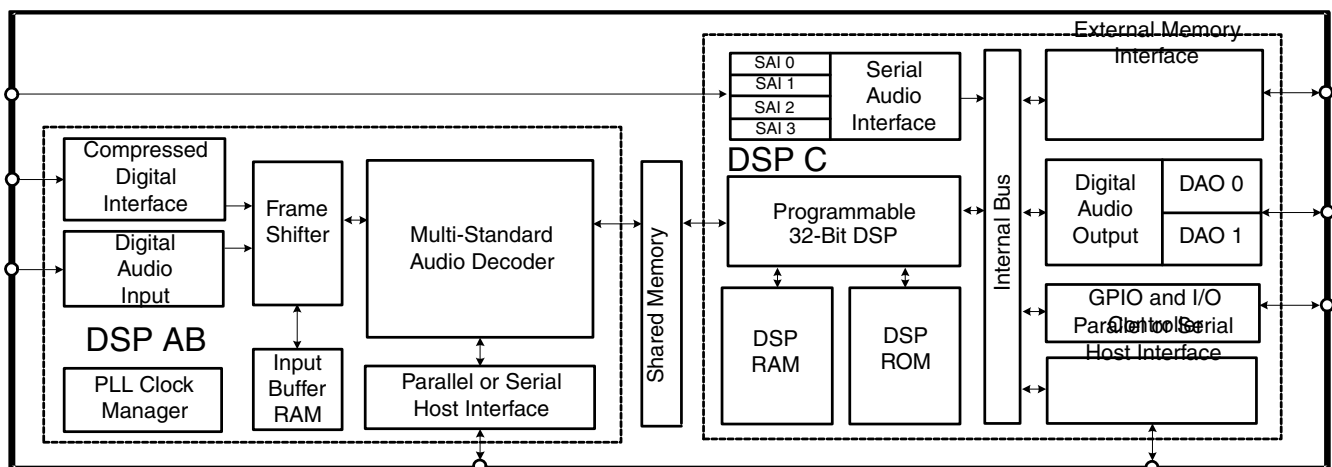

This document contains information for a new product.  
Cirrus Logic reserves the right to modify this product without notice.



## 2. OVERVIEW

The CS49400 is a 24-bit fixed-point decoder DSP followed by a 32-bit fixed point programmable post-processor DSP. The decoder portion of the CS49400 is referred to as “DSPAB”. The post-processor DSP is referred to as “DSPC”. Both DSPAB and DSPC include their own dedicated peripherals such as serial and parallel control ports, and serial audio interfaces. DSPC also has an external memory interface which supports SRAM/SDRAM/EPROM.

All the decoding/processing algorithms listed below require delivery of PCM or IEC61937-packed compressed data via I2S or LJ formatted digital audio to the CS49400. Today the CS49400 will support all of the following decoding/processing standards:

- PCM Pass-Through/PCM Upsampler
- Dolby Digital™ (with Dolby Pro Logic™)
- Dolby Digital Pro Logic II™
- Dolby Digital EX™
- Dolby Digital EX Pro Logic II™
- MPEG-2, Advanced Audio Coding Algorithm (AAC)
- MPEG Multichannel
- MPEG Multichannel with Dolby Pro Logic II™
- MPEG-1/2, Layer III (MP3)
- DTS Digital Surround™
- DTS 96/24™ (Front-end Decoder)
- DTS Digital Surround™ with Dolby Pro Logic II™
- DTS-ES Extended Surround™ (DTS-ES Discrete 6.1 and DTS-ES Matrix 6.1)
- DTS-ES 96/24™ (Front-end Decoder)
- DTS Neo:6™
- LOGIC7®
- SRS Circle Surround™ II

- HDCD®

All of the above audio decoding/processing algorithms and the associated application notes (AN208 and their corresponding appendices) are available through the Crystal Ware™ Software Licensing Program. Please refer to AN208 for the latest listing of application codes for DSPAB.

DSPC is unique to DSPAB in the sense that the designer may choose to just load a standard or enhanced application code (.ULD file) from the Crystal Ware Software Library or if they have access to the Cirrus Framework DSPC Development Kit, they may choose to build their own application code from a variety of modules. A DSPC application code contains all of the necessary post-processing modules, such as Crossbar Mixer, Pro Logic Module, Bass Manager Module, and Audio Manager (Kernel). A module is just a single processing module, such as Tone Control, Parametric/Graphic EQ, or Dolby Pro Logic matrix decoder. DSPC on the CS49400 will support the following post-processing application codes and/or modules:

- Standard Post-Processor (includes the following modules all compiled into one .ULD file): Downmixer module, Dualzone module, Crossbar Mixer module, 7.1 Channel Bass Manager module, Audio Manager module (Volume Control, Trim Control and Channel Remap), and Delay module
- Advanced Post-Processor (includes the all of the standard post-processing modules plus the Tone Control module, Parametric EQ module, Re-EQ module in all compiled into one .ULD )
- Dolby Pro Logic™
- Dolby Pro Logic II™
- SRS Circle Surround II™
- DTS Neo:6™
- LOGIC7®
- THX® Surround EX™ 7.1 Channel Post-Processor



- THX<sup>®</sup> Ultra2 Cinema<sup>™</sup> 7.1 Channel Post-Processor
- Cirrus Extra Surround<sup>™</sup>
- Cirrus Original Multichannel Surround<sup>™</sup>
- Virtual Dolby Digital<sup>™</sup>/Virtual Dolby Digital Pro Logic II<sup>™</sup> Virtualizer Module
- VMaX VirtualTheater<sup>™</sup> Virtualizer Module
- HDCD<sup>®</sup> Multichannel Decoder
- DVD-Audio/Video and Multichannel SACD Bass Management
- DTS/DTS-ES 96/24<sup>™</sup> Back-End Decoder
- DTS/DTS-ES 96/24<sup>™</sup> Back-End Decoder with THX<sup>®</sup> Ultra2 Cinema<sup>™</sup>

All of the above audio post-processing applications codes and/or Cirrus Framework<sup>™</sup> modules and the associated application notes (AN209 and the associated appendices) are available through the Crystal Ware<sup>™</sup> Software Licensing Program. All standard or enhanced post-processing code modules are only available to customers who qualify for the Cirrus Framework<sup>™</sup> CS49400 Family DSPC Programming Kit. Please refer to AN209 for the latest listing of application codes and Cirrus Framework<sup>™</sup> modules available for DSPC.

## 2.1 DSPAB

DSPAB is an enhanced version of the CS49300. It was designed to have legacy code support for all decoder applications developed for the CS49300. It includes performance enhancements such as the ability to decode AAC without the need for external SRAM memory. DSPAB has a Digital Audio Input (DAI) and a Compressed Data Input (CDI) port for data delivery in either I<sup>2</sup>S or LJ format. DSPAB can be controlled serially using the SPI standard and can also be controlled via a Parallel host control port using the Motorola<sup>®</sup> or Intel<sup>®</sup> communication standards.

## 2.2 DSPC

DSPC is a 32-bit, general-purpose, fixed-point RAM-based processor which includes on-chip ROM tables. It has been designed with a generous amount of on-chip program and data RAM, and has all necessary peripherals required to support the latest standards in consumer entertainment products such as AV receivers and DVD-Audio/Video players.

DSPC has on-chip data and program RAM, and both external SDRAM and SRAM memory interfaces. These interfaces can be used to expand the data memory. DSPC also has its own 8-channel digital audio input for post-processing PCM from a Multichannel Super Audio CD (SACD) input or DVD-Audio/Video input, via high-performance A/Ds or from some other type of multichannel digital input, capable of delivering 4 stereo digital audio channels such as IEEE1394 (a.k.a. I-Link<sup>®</sup> or Firewire<sup>®</sup>). Data can be delivered to this port using the standard audio formats (I<sup>2</sup>S or LJ). DSPC can be controlled serially using the SPI standard or via Parallel host control port using the Motorola<sup>®</sup> or Intel<sup>®</sup> standard. DSPC has a Digital Audio output port that has eight stereo serial data outputs for a total of 16 channels. Data can be delivered from these outputs in serial I<sup>2</sup>S or LJ format. Two of these outputs (AUDAT3, AUDAT7) can be configured as a IEC60958-format S/PDIF transmitter.

This document focuses on the electrical features of the CS49400. The features are described from a hardware design perspective. It should be understood that not all of the features portrayed in this document are supported by all of the versions of application code available. The application code user's guides should be consulted to determine which hardware features are supported by the software.

Please note that a download of application software is required each time the part is powered up. This term should be interpreted as meaning the transfer of application code into the internal memory of the part





from either an external microcontroller or through one of the boot procedures listed in Section 8.

### 3. TYPICAL CONNECTION DIAGRAMS

Four typical connection diagrams have been presented to illustrate using the part with the different communication modes available. They are as follows:

Figure 27, "SPI Control with External Memory - 144 Pin Package" on page 38.

Figure 28, "Intel® Parallel Control Mode - 144 Pin Package" on page 39.

Figure 29, "Motorola® Parallel Control Mode - 144 Pin Package" on page 40.

The following should be noted when viewing the typical connection diagrams:

**Note:** The pins are grouped functionally in each of the typical connection diagrams. Please be aware that the CS49400 symbol may appear differently in each diagram.

The external memory interface is supported when a serial or parallel communication mode has been chosen.

#### 3.1 Multiplexed Pins

The CS49400 incorporates a large amount of flexibility into a 144 pin package. The pins are internally multiplexed to serve multiple purposes. Some pins are designed to operate in one mode at power up, and serve a different purpose when the DSP is running. Other pins have functionality which can be controlled by the application running on the DSP. In order to better explain the behavior of the part, the pins which are multiplexed have been given multiple names. Each name is specific to the pin's operation in a particular mode.

In this document, pins will be referred to by their functionality. Section 12 "Pin Description" on page 86 describes each pin of the CS49400 and lists all of its names. Please refer to this section when exact pin numbers are in question.

#### 3.2 Termination Requirements

The CS49400 incorporates open drain pins which must be pulled high for proper operation.  $\overline{\text{FINTREQ}}$  and  $\overline{\text{INTREQ}}$  are always open drains which requires a pull-up for proper operation.

Due to the internal, multiplexed design of the pins, certain signals may or may not require termination depending on the mode being used. If a parallel host communication mode is not being used, all parallel control pins must be terminated or driven as these pins will come up as high impedance inputs and will be prone to oscillation if they are left floating. The specific termination requirements may vary since the state of some of the GPIO pins will determine the communication mode at the rising edge of reset (please see Section 6 "Control" on page 41 for more information). For the explicit termination requirements of each communication mode please see the typical connection diagrams.

Generally a 3.3k Ohm resistor is recommended for open drain and mode select pins. A 10k Ohm resistor is sufficient for all other unused inputs.

#### 3.3 Phase Locked Loop Filter

The internal phase locked loop (PLL) of the CS49400 requires an external filter. The topology of this filter is shown in the typical connection diagrams. The component values are shown below. Care should be taken when laying out the filter circuitry to minimize trace lengths and to avoid any high frequency signals. Any noise coupled onto the filter circuit will be directly coupled into the PLL, which could affect performance.

Reference Designator	Value
C1	2.2uF
C2	1200pF
C3	68pF
R1	3k Ohm

Table 1. PLL Filter Component Values



## 4. POWER

The CS49400 requires a 2.5V digital power supply for the core logic and 2.5V I/O and a 2.5V analog power supply for the internal PLL. For systems with external memory that runs on 3.3V, a 3.3V digital power supply is required on the VDDSD pins along with four digital grounds on VSSSD. There are seven digital power pins, VDD1 through VDD7, along with seven digital grounds, VSS1 through VSS7. There is one analog power pin, PLLVDD, and one analog ground, PLLVSS. The recommendations given below for decoupling and power conditioning of the CS49400 will help to ensure reliable performance.

### 4.1 Decoupling

It is necessary to decouple the power supply by placing capacitors directly between the power and ground of the CS49400. Each pair of power/ground pins (VDD1/VSS1, etc.) should have its own decoupling capacitors. The recommended procedure is to place both a 0.1 $\mu$ F and a 1 $\mu$ F capacitor as close as physically possible to each power pin. The 0.1 $\mu$ F capacitor should be closest to the part (typically 5mm or closer).

### 4.2 Analog Power Conditioning

In order to obtain the best performance from the CS49400's internal PLL, the analog power supply PLLVDD must be as noise-free as possible. A ferrite bead and two capacitors should be used to filter the VDD to generate PLLVDD. This power scheme is shown in the typical connection diagrams.

### 4.3 Ground

For two layer circuit boards, care should be taken to have sufficient ground between the DSP and parts in which it will be interfacing (DACs, ADCs, S/PDIF Receivers, microcontrollers, and especially external memory). Insufficient ground can degrade noise margins between devices resulting in data integrity problems.

### 4.4 Pads

The CS49400 has two different I/O voltage levels. All signal pins not associated with the External SRAM/SDRAM memory interface operate from the 2.5V supply and are 3.3V tolerant. The external SRAM/SDRAM memory interface operates at 3.3V only. However, if the external memory interface is not used VDDSD1-4 may be connected to 2.5V.



## 12.0 PIN DESCRIPTION

### 12.1 144-Pin LQFP Package Pin Layout

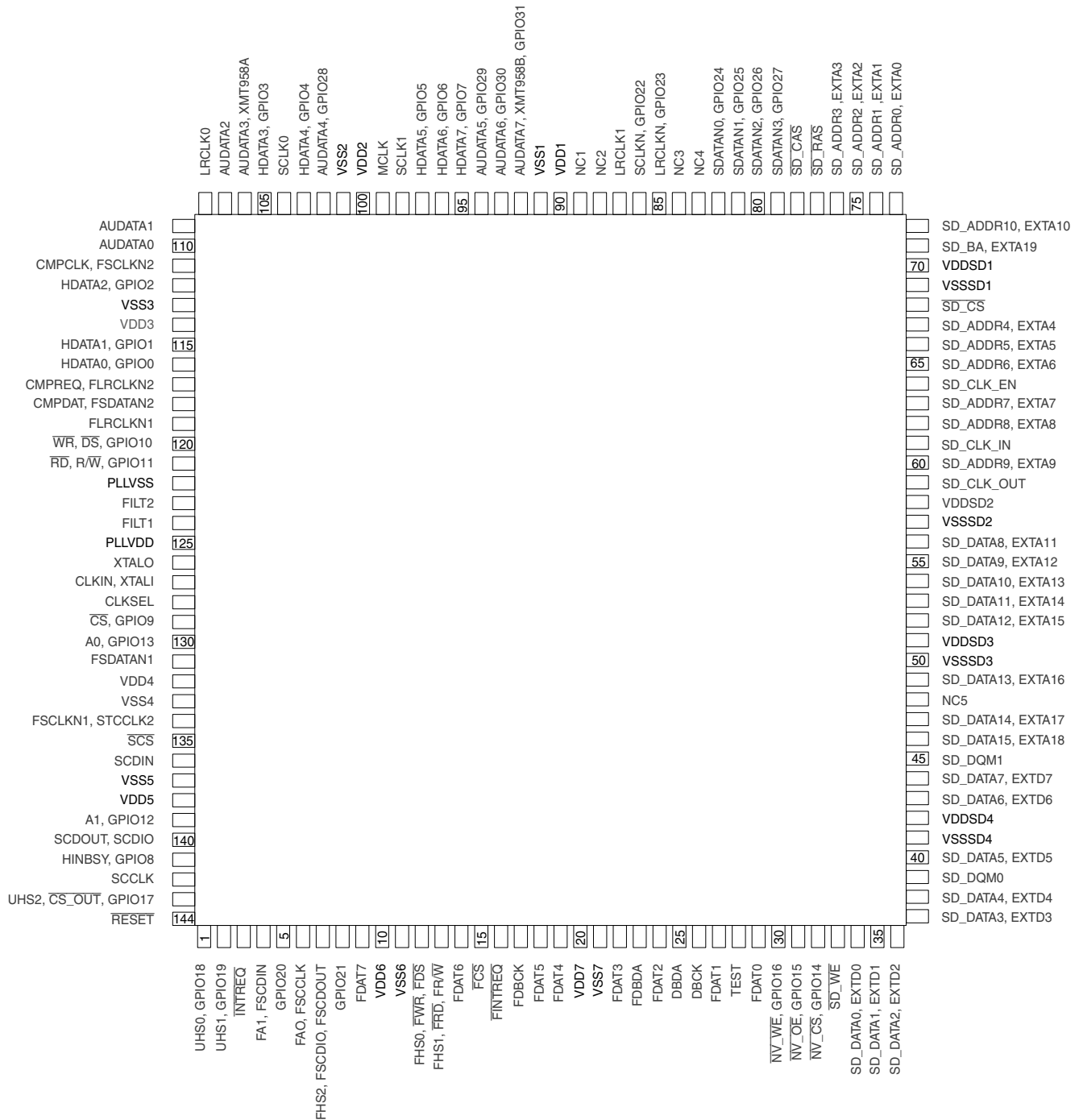

Figure 57. Pin Layout (144-Pin LQFP Package)





## 12.3 Pin Definitions

### FILT1 — Phase-Locked Loop Filter

Connects to an external filter for the on-chip phase-locked loop.

### FILT2 — Phase Locked Loop Filter

Connects to an external filter for the on-chip phase-locked loop.

### CLKIN, XTALI — External Clock Input/Crystal Oscillator Input

CS49400 clock input. This pin accepts an external clock input signal that is used to drive the internal core logic. When in internal clock mode (CLKSEL == VSS), this input is connected to the internal PLL from which all internal clocks are derived. When in external clock mode (CLKSEL == VDD), this input is connected to the DSP clock. Alternatively, a 12.288 mHz crystal oscillator can be connected between XTALI and XTALO. *INPUT*

### XTALO — Crystal Oscillator Output

Crystal oscillator output. *OUTPUT*

### CLKSEL — DSP Clock Select

This pin selects the internal source clock. When CLKSEL is low, CLKIN is connected to the internal PLL from which all internal clocks are derived. When CLKSEL is high, the PLL is bypassed and the external clock directly drives all input logic. *INPUT*

### FDAT7 — DSPAB Bidirectional Data Bus

FDAT6

FDAT5

FDAT4

FDAT3

FDAT2

FDAT1

FDAT0

In parallel host mode, these pins provide a bidirectional data bus to DSPAB. These pins have an internal pull-up.

*BIDIRECTIONAL - Default: INPUT*

### FA0, FSCCLK — Host Parallel Address Bit Zero or Serial Control Port Clock

In parallel host mode, this pin serves as one of two address input pins used to select one of four parallel registers. In serial host mode, this pin serves as the serial control clock signal, specifically as the SPI clock input. *INPUT*



### **FA1, FSCDIN — Host Address Bit One or SPI Serial Control Data Input**

In parallel host mode, this pin serves as one of two address input pins used to select one of four parallel registers. In SPI serial host mode, this pin serves as the data input. *INPUT*

### **FHS1, $\overline{\text{FRD}}$ , $\overline{\text{FRW}}$ — Mode Select Bit 1 or Host Parallel Output Enable or Host Parallel R/W**

DSPAB control port mode select bit 1. This bit is one of 3 control port select bits that are sampled on the rising edge of  $\overline{\text{RESET}}$  to determine the control port mode of DSPAB. In Intel parallel host mode, this pin serves as the active-low data bus enable input. In Motorola parallel host mode, this pin serves as the read-high/write-low control input signal. In serial host mode, this pin can serve as the external memory active-low data-enable output signal. *BIDIRECTIONAL - Default: INPUT*

### **FHS0, $\overline{\text{FWR}}$ , $\overline{\text{FDS}}$ — Mode Select Bit 0 or Host Write Strobe or Host Data Strobe**

DSPAB control port mode select bit 0. This bit is one of 3 control port select bits that are sampled on the rising edge of  $\overline{\text{RESET}}$  to determine the control port mode of DSPAB. In Intel parallel host mode, this pin serves as the active-low data-write-input strobe. In Motorola parallel host mode, this pin serves as the active-low data-strobe-input signal. In serial host mode, this pin can serve as the external-memory active-low write-enable output signal. *BIDIRECTIONAL - Default: INPUT*

### **$\overline{\text{FCS}}$ — Host Parallel Chip Select, Host Serial SPI Chip Select**

In parallel host mode, this pin serves as the active-low chip-select input signal. In serial host SPI mode, this pin is used as the active-low chip-select input signal. *INPUT*

### **FHS2, FSCDIO, FSCDOUT — Mode Select Bit 2 or Serial Control Port Data Input and Output, Parallel Port Type Select**

DSPAB control port mode select bit 2. This bit is one of 3 control port select bits that are sampled on the rising edge of  $\overline{\text{RESET}}$  to determine the control port mode of DSPAB. In SPI mode this pin serves as the data output pin. In parallel host mode, this pin is sampled at the rising edge of  $\overline{\text{RESET}}$  to configure the parallel host mode as an Intel type bus or as a Motorola type bus. *BIDIRECTIONAL - Default: INPUT*

### **$\overline{\text{FINTREQ}}$ — Control Port Interrupt Request**

Open-drain interrupt-request output. This pin is driven low to indicate that the DSP has outgoing control data that should be read by the host.

*OPEN DRAIN I/O - Requires 3.3K Ohm Pull-Up*

### **FSCLKN1, STCLK2 — PCM Audio Input Bit Clock**

Digital-audio bit clock input. FSCLKN1 operates asynchronously from all other DSPAB clocks. In master mode, FSCLKN1 is derived from DSPAB's internal clock generator. The active edge of FSCLKN1 can be programmed by the DSP.

*BIDIRECTIONAL - Default: INPUT*

### **FLRCLKN1 — PCM Audio Input Sample Rate Clock**



Digital-audio frame clock input. FLRCLKN1 typically is run at the sampling frequency. FLRCLKN1 operates asynchronously from all other DSPAB clocks. The polarity of FLRCLKN1 for a particular subframe can be programmed by the DSP.

*BIDIRECTIONAL - Default: INPUT*

#### **FSDATAN1 — PCM Audio Data Input One**

Digital-audio data input that can accept from one compressed line or 2 channels of PCM data. FSDATAN1 can be sampled with either edge of FSCLKN1, depending on how FSCLKN1 has been configured. *INPUT*

#### **CMPCLK, FSCLKN2 — PCM Audio Input Bit Clock**

Digital-audio bit clock input. FSCLKN2 operates asynchronously from all other DSPAB clocks. The active edge of FSCLKN2 can be programmed by the DSP.

*BIDIRECTIONAL - Default: INPUT*

#### **CMPDAT, FSDATAN2 — PCM Audio Data Input Number Two**

Digital-audio data input that can accept either one compressed line or 2 channels of PCM data. FSDATAN2 can be sampled with either edge of FSCLKN2, depending on how FSCLKN2 has been configured.

*BIDIRECTIONAL - Default: INPUT*

#### **FDBCK — Reserved**

This pin is reserved and should be pulled up with an external 3.3k resistor. *INPUT*

#### **FDBDA — Reserved**

This pin is reserved and should be pulled up with an external 3.3k resistor.

*BIDIRECTIONAL - Default: INPUT*

#### **PLLVDV — PLL Supply Voltage**

2.5 V PLL supply.

#### **PLLVSS — PLL Ground Voltage**

PLL ground.

#### **$\overline{\text{RESET}}$ — Master Reset Input**

Asynchronous active-low master reset input. Reset should be low at power-up to initialize the DSP and to guarantee that the device is not active during initial power-on stabilization periods. At the rising edge of reset the host interface mode of DSPAB is selected contingent on the state of the FHS0, FHS1, and FHS2 pins. At the rising edge of reset the host interface mode of DSPC is selected contingent on the state of the UHS0, UHS1, and UHS2 pins. If reset is low all bidirectional pins are high-Z inputs. *INPUT*

#### **TEST — Reserved**



This should be tied low for normal operation. *INPUT*

### **MCLK — Audio Master Clock**

Bidirectional master audio clock. As an output, MCLK provides a low jitter oversampling clock. MCLK supports all standard oversampling frequencies. *BIDIRECTIONAL - Default: INPUT*

### **SCLK0 — Audio Output Bit Clock**

Bidirectional digital-audio output bit clock for AUDATA0, AUDATA1, AUDATA2, and AUDATA3. As an output, SCLK0 can provide 32 Fs, 64 Fs, 128 Fs, 256 Fs, or 512 Fs frequencies and is synchronous to MCLK. As an input, SCLK0 is independent of MCLK.

*BIDIRECTIONAL - Default: INPUT*

### **SCLK1 — Audio Output Bit Clock**

Bidirectional digital-audio output bit clock for AUDATA4, AUDATA5, AUDATA6, and AUDATA7. As an output, SCLK1 can provide 32 Fs, 64 Fs, 128 Fs, 256 Fs, or 512 Fs frequencies and is synchronous to MCLK. As an input, SCLK1 is independent of MCLK.

*BIDIRECTIONAL - Default: INPUT*

### **LRCLK0 — Audio Output Sample Rate Clock**

Bidirectional digital-audio output frame clock for AUDATA0, AUDATA1, AUDATA2, and AUDATA3. As an output, LRCLK0 can provide all standard output sample rates up to 192 kHz and is synchronous to MCLK. As an input, LRCLK0 is independent of MCLK.

*BIDIRECTIONAL - Default: INPUT*

### **LRCLK1 — Audio Output Sample Rate Clock**

Bidirectional digital-audio output frame clock for AUDATA4, AUDATA5, AUDATA6, and AUDATA7. As an output, LRCLK1 can provide all standard output sample rates up to 192 kHz and is synchronous to MCLK. As an input, LRCLK1 is independent of MCLK.

*BIDIRECTIONAL - Default: INPUT*

### **AUDATA0 — Digital Audio Output 0**

PCM digital-audio data output. *OUTPUT*

### **AUDATA1 — Digital Audio Output 1**

PCM digital-audio data output. *OUTPUT*

### **AUDATA2 — Digital Audio Output 2**

PCM digital-audio data output. *OUTPUT*

### **AUDATA3, XMT958A — Digital Audio Output 3, S/PDIF Transmitter**





CMOS level output that outputs a biphase-mark encoded (S/PDIF) IEC60958 signal or digital audio data which is capable of carrying two channels of PCM digital audio. *OUTPUT*

**AUDATA4, GPIO28 — Digital Audio Output 4, General Purpose I/O**

PCM digital-audio data output. This pin can act as a general-purpose input or output that can be individually configured and controlled by DSPC. *BIDIRECTIONAL - Default: OUTPUT*

**AUDATA5, GPIO29 — Digital Audio Output 5, General Purpose I/O**

PCM digital-audio data output. This pin can act as a general-purpose input or output that can be individually configured and controlled by DSPC. *BIDIRECTIONAL - Default: OUTPUT*

**AUDATA6, GPIO30 — Digital Audio Output 6, General Purpose I/O**

PCM digital-audio data output. This pin can act as a general-purpose input or output that can be individually configured and controlled by DSPC. *BIDIRECTIONAL - Default: OUTPUT*

**AUDATA7, XMT958B, GPIO31 — Digital Audio Output 7, S/PDIF Transmitter, General Purpose I/O**

CMOS level output that contains a biphase-mark encoded (S/PDIF) IEC60958 signal or digital audio data which is capable of carrying two channels of PCM digital audio. This pin can also act as a general-purpose input or output that can be individually configured and controlled by DSPC. *BIDIRECTIONAL - Default: OUTPUT*

**DBCK — Debug Clock**

Must be tied high to 3.3k ohm resistor. *INPUT*

**DBDA — Debug Data**

Must be tied high to 3.3k ohm resistor. *BIDIRECTIONAL - Default: INPUT*

**SLCKN, GPIO22 — PCM Audio Input Bit Clock, General Purpose I/O**

Digital-audio bit clock that is an input. SCLKN operates asynchronously from all other DSPAB clocks. The active edge of SCLKN can be programmed by the DSP. This pin can act as a general-purpose input or output that can be individually configured and controlled by DSPC. *BIDIRECTIONAL - Default: INPUT*

**LRCLKN, GPIO23 — PCM Audio Input Sample Rate Clock, General Purpose I/O**

Digital-audio frame clock input. LRCLKN operates asynchronously from all other DSPAB clocks. The polarity of LRCLKN for a particular subframe can be programmed by the DSP. This pin can act as a general-purpose input or output that can be individually configured and controlled by DSPC. *BIDIRECTIONAL - Default: INPUT*

**SDATAN0, GPIO24 — PCM Audio Input Data, General Purpose I/O**

Digital-audio PCM data input. This pin can act as a general-purpose input or output that can be individually configured and controlled by DSPC. *BIDIRECTIONAL - Default: INPUT*

**SDATAN1, GPIO25 — PCM Audio Input Data, General Purpose I/O**



Digital-audio PCM data input. This pin can act as a general-purpose input or output that can be individually configured and controlled by DSPC. *BIDIRECTIONAL - Default: INPUT*

#### **SDATAN2, GPIO26 — PCM Audio Input Data, General Purpose I/O**

Digital-audio PCM data input. This pin can act as a general-purpose input or output that can be individually configured and controlled by DSPC. *BIDIRECTIONAL - Default: INPUT*

#### **SDATAN3, GPIO27 — PCM Audio Input Data, General Purpose I/O**

Digital-audio PCM data input. This pin can act as a general-purpose input or output that can be individually configured and controlled by DSPC. *BIDIRECTIONAL - Default: INPUT*

#### **SCS — Host Serial SPI Chip Select**

SPI mode active-low chip-select input signal. *INPUT*

#### **SCCLK — Serial Control Port Clock**

This pin serves as the serial SPI clock input. *INPUT*

#### **SCDIN — SPI Serial Control Data Input**

In SPI mode this pin serves as the data input pin. *INPUT*

#### **SCDOUT, SCDIO — Serial Control Port Data Input and Output**

In SPI mode this pin serves as the data output pin. *BIDIRECTIONAL - Default: OUTPUT in SPI mode*

#### **INTREQ — Control Port Interrupt Request**

Open-drain interrupt-request output. This pin is driven low to indicate that DSPC has outgoing control data and should be serviced by the host.  
*OPEN DRAIN I/O - Requires 3.3K Ohm Pull-Up*



### **HDATA7, GPIO7 — DSPC Bidirectional Data Bus, General Purpose I/O**

**HDATA6, GPIO6**

**HDATA5, GPIO5**

**HDATA4, GPIO4**

**HDATA3, GPIO3**

**HDATA2, GPIO2**

**HDATA1, GPIO1**

**HDATA0, GPIO0**

In parallel host mode, these pins provide a bidirectional data bus. These pins can also act as general purpose input or output pins that can be individually configured and controlled by DSPC. These pins have an internal pull-up. *BIDIRECTIONAL - Default: INPUT*

### **A0, GPIO13 — Host Parallel Address Bit 0, General Purpose I/O**

In parallel host mode, this pin serves as the LS Bit of a two bit address input used to select one of four parallel registers. This pin can act as a general-purpose input or output that can be individually configured and controlled by DSPC. *BIDIRECTIONAL - Default: INPUT*

### **A1, GPIO12 — Host Address Bit 1, General Purpose I/O**

In parallel host mode, this pin serves as the MS Bit of a two bit address input used to select one of four parallel registers. This pin can act as a general-purpose input or output that can be individually configured and controlled by DSPC. *BIDIRECTIONAL - Default: INPUT*

### **$\overline{RD}$ , $\overline{R/W}$ , GPIO11 — Host Parallel Output Enable, Host Parallel $\overline{R/W}$ , General Purpose I/O**

In Intel parallel host mode, this pin serves as the active-low data bus enable input. In Motorola parallel host mode, this pin serves as the read-high/write-low control input signal. This pin can act as a general-purpose input or output that can be individually configured and controlled by DSPC. This pin has an internal pull-up. *BIDIRECTIONAL - Default: INPUT*

### **$\overline{WR}$ , $\overline{DS}$ , GPIO10 — Host Write Strobe, Host Data Strobe, General Purpose I/O**

In Intel parallel host mode, this pin serves as the active-low data bus enable input. In Motorola parallel host mode, this pin serves as the read-high/write-low control input signal. In serial host mode, this pin can serve as a general purpose input or output bit. This pin can act as a general-purpose input or output that can be individually configured and controlled by DSPC. This pin has an internal pull-up.  
*BIDIRECTIONAL - Default: INPUT*

### **$\overline{CS}$ , GPIO9 — Host Parallel Chip Select, General Purpose I/O**

In parallel host mode, this pin serves as the active-low chip-select input signal. This pin can act as a general-purpose input or output that can be individually configured and controlled by DSPC. This pin has an internal pull-up. *BIDIRECTIONAL - Default: INPUT*



### **HINBSY, GPIO8 — Input Host Message Status, General Purpose I/O**

This pin indicates that serial or parallel communication data written to the DSP has not been read yet. This pin can act as a general-purpose input or output that can be individually configured and controlled by DSPC. This pin has an internal pull-up. *BIDIRECTIONAL - Default: OUTPUT*

### **SD\_DATA15, EXTA18 — SDRAM Data Bus, SRAM External Address Bus**

**SD\_DATA14, EXTA17**

**SD\_DATA13, EXTA16**

**SD\_DATA12, EXTA15**

**SD\_DATA11, EXTA14**

**SD\_DATA10, EXTA13**

**SD\_DATA9, EXTA12**

**SD\_DATA8, EXTA11**

SDRAM data bus 15:8. SRAM external address bus 18:11. *OUTPUT*

### **SD\_DATA7, EXTD7 — SDRAM Data Bus, SRAM External Data Bus**

**SD\_DATA6, EXTD6**

**SD\_DATA5, EXTD5**

**SD\_DATA4, EXTD4**

**SD\_DATA3, EXTD3**

**SD\_DATA2, EXTD2**

**SD\_DATA1, EXTD1**

**SD\_DATA0, EXTD0**

SDRAM data bus 7:0. SRAM external data bus 7:0. *BIDIRECTIONAL - Default: INPUT*

### **SD\_ADDR10, EXTA10 — SDRAM Address Bus, SRAM External Address Bus**

**SD\_ADDR9, EXTA9**

**SD\_ADDR8, EXTA8**

**SD\_ADDR7, EXTA7**

**SD\_ADDR6, EXTA6**

**SD\_ADDR5, EXTA5**

**SD\_ADDR4, EXTA4**

**SD\_ADDR3, EXTA3**

**SD\_ADDR2, EXTA2**

**SD\_ADDR1, EXTA1**

**SD\_ADDR0, EXTA0**

SDRAM address bus 10:0. SRAM external address bus 10:0. *OUTPUT*

**SD\_CLK\_OUT — SDRAM Clock Output**SDRAM clock output. *OUTPUT***SD\_CLK\_IN — SDRAM Re-timing Clock Input**SDRAM re-timing clock input. *INPUT***SD\_CLK\_EN — SDRAM Clock Enable**SDRAM clock enable. *OUTPUT***SD\_BA, EXTA19 — SDRAM Bank Address Select, SRAM External Address Bus**SDRAM bank address select. SRAM external address bus 19. *OUTPUT* **$\overline{\text{SD\_CS}}$  — SDRAM Chip Select**SDRAM chip select. *OUTPUT* **$\overline{\text{SD\_RAS}}$  — SDRAM Row Address Strobe**SDRAM row address strobe. *OUTPUT* **$\overline{\text{SD\_CAS}}$  — SDRAM Column Address Strobe**SDRAM column address strobe. *OUTPUT* **$\overline{\text{SD\_WE}}$  — SDRAM Write Enable**SDRAM write enable. *OUTPUT***SD\_DQM1 — SDRAM Data Mask 1**SDRAM data mask 1. *OUTPUT***SD\_DQM0 — SDRAM Data Mask 2**SDRAM data mask 0. *OUTPUT* **$\overline{\text{NV\_CS}}$ , GPIO14 — SRAM Chip Select, General Purpose I/O**SRAM/Flash chip select. This pin can act as a general-purpose input or output that can be individually configured and controlled by DSPC. *BIDIRECTIONAL - Default: OUTPUT* **$\overline{\text{NV\_OE}}$ , GPIO15 — SRAM Output Enable, General Purpose I/O**SRAM/Flash output enable. This pin can act as a general-purpose input or output that can be individually configured and controlled by DSPC. *BIDIRECTIONAL - Default: OUTPUT*



### **NV\_WE, GPIO16 — SRAM Write Enable, General Purpose I/O**

SRAM/Flash write enable. This pin can act as a general-purpose input or output that can be individually configured and controlled by DSPC. *BIDIRECTIONAL - Default: OUTPUT*

### **UHS2, CS\_OUT, GPIO17 — Mode Select Bit 2, External Serial Memory Chip Select, General Purpose I/O**

DSPC control port mode select bit 2. This pin is sampled at the rising edge of  $\overline{\text{RESET}}$  and is one of three pins used to select the control port mode. In serial control port mode, this pin can serve as an output to provide the chip-select for a serial EEPROM. This pin can act as a general-purpose input or output that can be individually configured and controlled by DSPC. *BIDIRECTIONAL - Default: INPUT*

### **UHS0, GPIO18 — Mode Select Bit 0, General Purpose I/O**

DSPC control port mode select bit 0. This pin is sampled at the rising edge of  $\overline{\text{RESET}}$  and is one of three pins used to select the control port mode. This pin can act as a general-purpose input or output that can be individually configured and controlled by DSPC. *BIDIRECTIONAL - Default: INPUT*

### **UHS1, GPIO19 — Mode Select Bit 1, General Purpose I/O**

DSPC control port mode select bit 1. This pin is sampled at the rising edge of  $\overline{\text{RESET}}$  and is one of three pins used to select the control port mode. This pin can act as a general-purpose input or output that can be individually configured and controlled by DSPC. *BIDIRECTIONAL - Default: INPUT*

### **GPIO20 — General Purpose I/O**

This pin can act as a general-purpose input or output that can be individually configured and controlled by DSPC. This pin has an internal pull-up. *BIDIRECTIONAL - Default: INPUT*

### **GPIO21 — General Purpose I/O**

This pin can act as a general-purpose input or output that can be individually configured and controlled by DSPC. This pin has an internal pull-up. *BIDIRECTIONAL - Default: INPUT*

### **VDD[7:1] — 2.5V Supply Voltage**

2.5V supply voltage.

### **VSS — 2.5V Ground**

2.5V ground.



---

**NC[5:1] — No Connect**

Recommended tie to ground.

**VDDSD[4:1] — 3.3V SDRAM/SRAM/EPROM Interface Supply**

3.3V SDRAM/SRAM/EPROM supply.

**VSSSD — 3.3V SDRAM/SRAM/EPROM Interface Ground**

3.3V ground.

BLOCK DIAGRAM

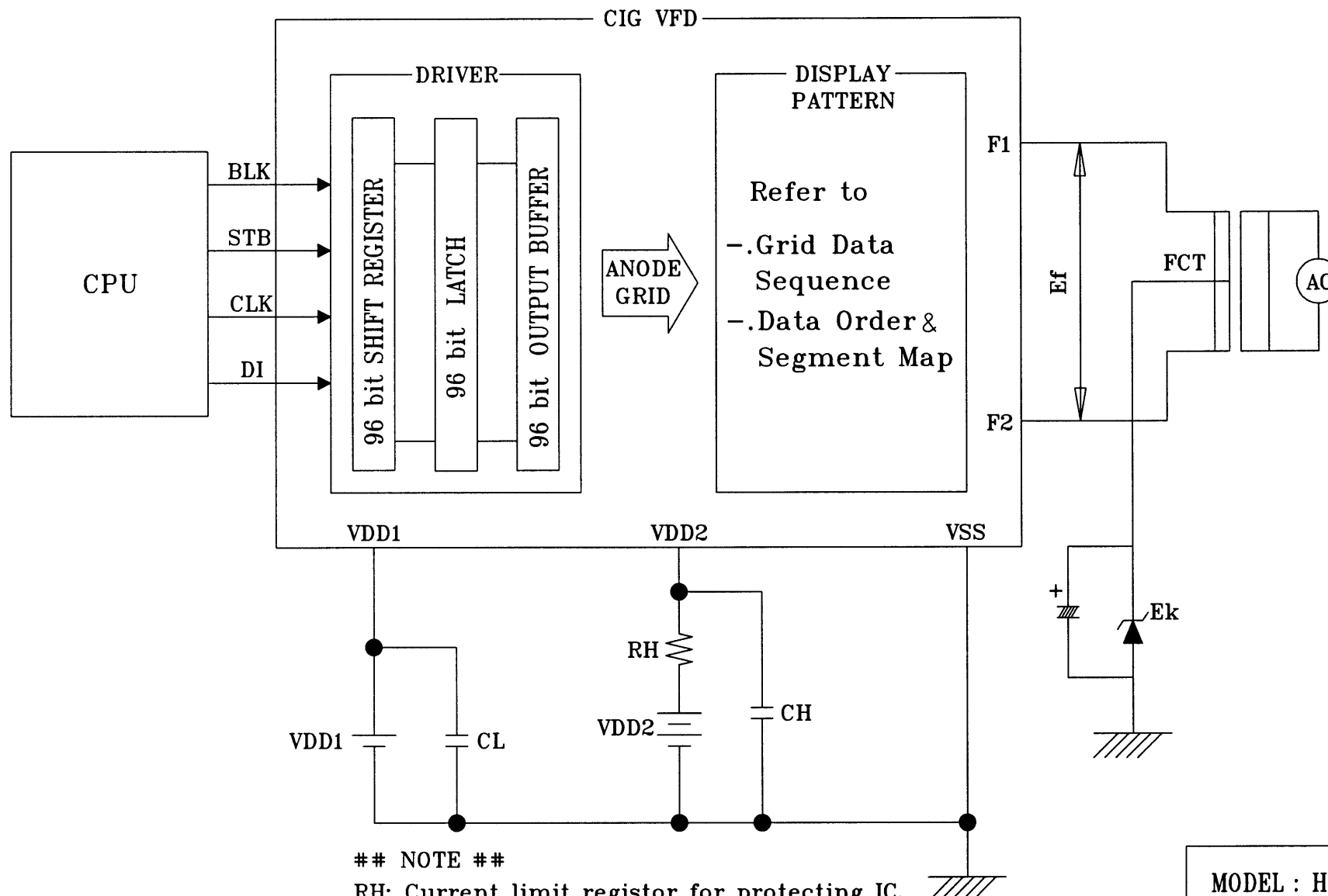

## NOTE ##

RH: Current limit resistor for protecting IC.

CH,CL: Low pass filter for noise filtering.

RH: 22Ω, CH: 0.1 μF, CL: 0.1 μF

FCT: Filament is center-tab grounded.

MODEL : HCA-18ML01  
 BLOCK DIAGRAM  
 Rev. ① 20-Feb-2003



**OUTER DIMENSIONS**

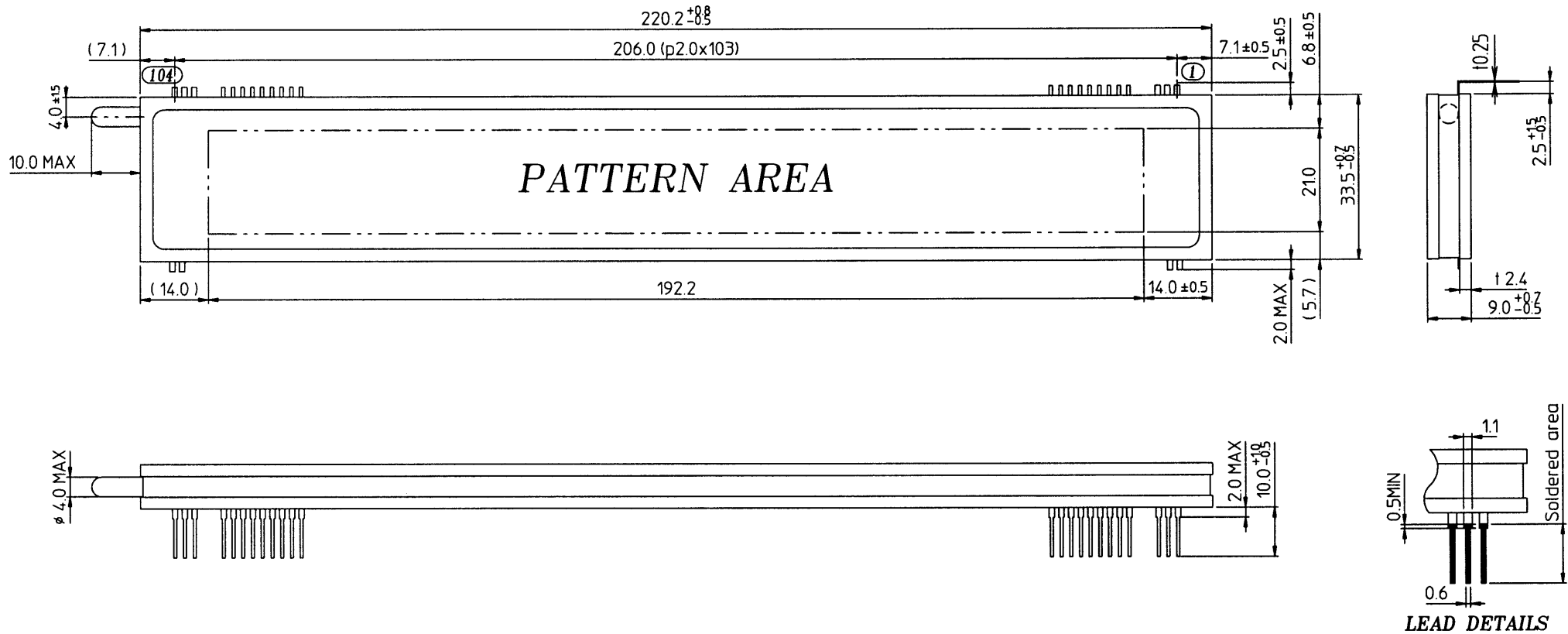

**PIN CONNECTION**

PIN NO.	104	103	102	101	100	99	98	97	96	95	94	93	92	91	90~15	14~6	5	4	3	2	1
CONNECTION	F2	F2	F2	NP	NP	VDD2	VSS	VSS	CLK	D0	DI	BLK	STB	VDD1	NP	NC	NP	NP	F1	F1	F1

**\*Notes**

Fn : Filament Pin

NP : No Pin

NC : No Connection Pin

\* D0(Serial data output) : Be left open if not used.

MODEL : HCA-18ML01  
 OUTER DIMENSIONS  
 Rev. ① 20-Feb-2003



## HCF4053B

### TRIPLE 2-CHANNEL ANALOG MULTIPLEXER/DEMULTIPLEXER

- LOW "ON" RESISTANCE : 125Ω (Typ.)  
OVER 15V p.p SIGNAL-INPUT RANGE FOR  
 $V_{DD} - V_{EE} = 15V$
- HIGH "OFF" RESISTANCE : CHANNEL  
LEAKAGE  $\pm 100pA$  (Typ.) at  $V_{DD} - V_{EE} = 18V$
- BINARY ADDRESS DECODING ON CHIP
- HIGH DEGREE OF LINEARITY :  $< 0.5\%$   
DISTORTION TYP. at  $f_{IS} = 1KHz$ ,  $V_{IS} = 5 V_{pp}$ ,  
 $V_{DD} - V_{SS} \geq 10V$ ,  $R_L = 10K\Omega$
- VERY LOW QUIESCENT POWER  
DISSIPATION UNDER ALL DIGITAL  
CONTROL INPUT AND SUPPLY  
CONDITIONS : 0.2  $\mu W$  (Typ.)  
at  $V_{DD} - V_{SS} = V_{DD} - V_{EE} = 10V$
- MATCHED SWITCH CHARACTERISTICS :  
 $R_{ON} = 5\Omega$  (Typ.) FOR  $V_{DD} - V_{EE} = 15V$
- WIDE RANGE OF DIGITAL AND ANALOG  
SIGNAL LEVELS : DIGITAL 3 to 20,  
ANALOG TO 20V p.p.
- QUIESCENT CURRENT SPECIF. UP TO 20V
- 5V, 10V AND 15V PARAMETRIC RATINGS
- INPUT LEAKAGE CURRENT  
 $I_l = 100nA$  (MAX) AT  $V_{DD} = 18V$   $T_A = 25^\circ C$
- 100% TESTED FOR QUIESCENT CURRENT
- MEETS ALL REQUIREMENTS OF JEDEC  
JESD13B " STANDARD SPECIFICATIONS  
FOR DESCRIPTION OF B SERIES CMOS  
DEVICES"

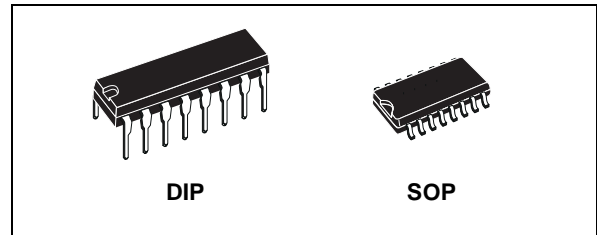

#### ORDER CODES

PACKAGE	TUBE	T & R
DIP	HCF4053BEY	
SOP	HCF4053BM1	HCF4053M013TR

technology available in DIP and SOP packages. The HCF4053B analog multiplexer/demultiplexer is a digitally controlled analog switch having low ON impedance and very low OFF leakage current. This multiplexer circuit dissipate extremely low quiescent power over the full  $V_{DD} - V_{SS}$  and  $V_{DD} - V_{EE}$  supply voltage range, independent of the logic state of the control signals.

When a logic "1" is present at the inhibit input terminal all channel are off. This device is a triple 2-channel multiplexer having three separate digital control inputs, A, B, and C, and an inhibit input. Each control input selects one of a pair of channels which are connected in a single pole double-throw configuration.

#### DESCRIPTION

The HCF4053B is a monolithic integrated circuit fabricated in Metal Oxide Semiconductor

#### PIN CONNECTION

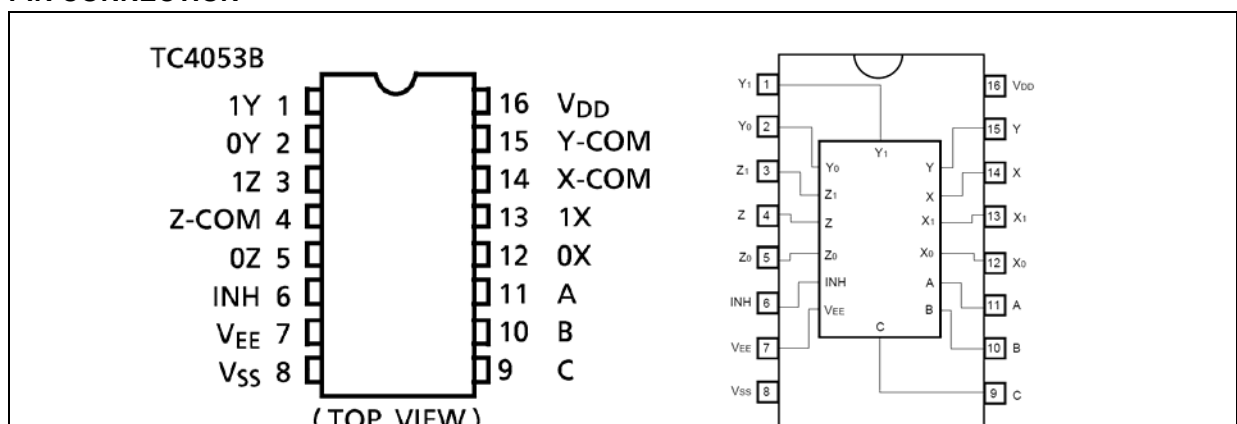

October 2002

HCF4053B

INPUT EQUIVALENT CIRCUIT

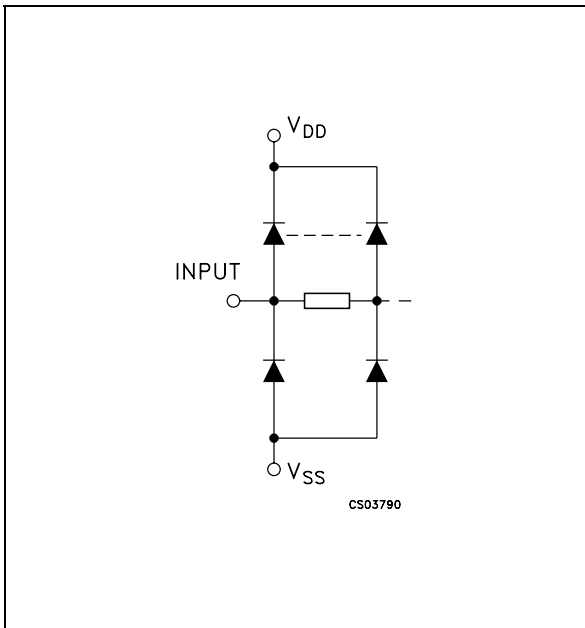

PIN DESCRIPTION

PIN No	SYMBOL	NAME AND FUNCTION
11, 10, 9	A, B, C	Binary Control Inputs
6	INH	Inhibit Inputs
12, 13, 2, 1, 5, 3	IN/OUT	ax,ay,bx,by,cx,cy Input/Output
14	OUT/IN	ax or ay
15	OUT/IN	bx or by
4	OUT/IN	cx or cy
7	V <sub>EE</sub>	Supply Voltage
8	V <sub>SS</sub>	Negative Supply Voltage
16	V <sub>DD</sub>	Positive Supply Voltage

TRUTH TABLE

INHIBIT	C or B or A	
0	0	ax or bx or cx
0	1	ay or by or cy
1	X	NONE

X : Don't Care

FUNCTIONAL DIAGRAM

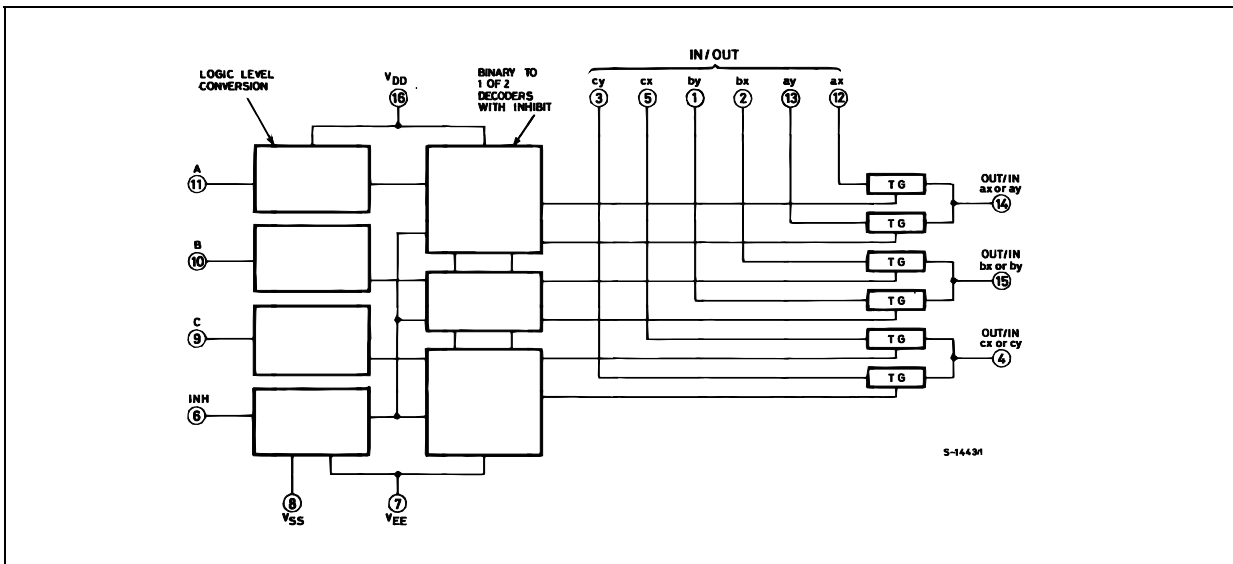

Ordering number : ※ EN5039

CMOS IC

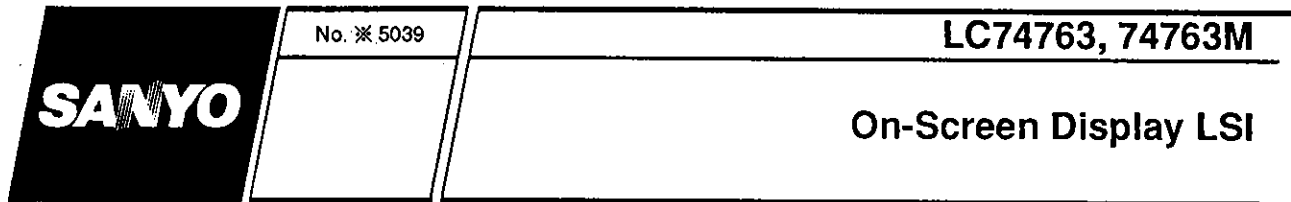

## Preliminary

### Overview

The LC74763 and LC74763M are on-screen display CMOS LSIs that superimpose text and low-level graphics onto a TV screen (video signal) under the control of a microcontroller. The display characters have a 12 by 18 dots structure, and 128 characters are provided.

### Features

- Display structure: 12 lines by 24 characters (up to 288 characters)
- Maximum character display: Up to 288 characters
- Character configuration: 12 (W) by 18 (H) dots structure
- Number of characters: 128 characters (128 plus space 2 fonts)
- Character sizes: Three sizes (normal, double, and triple sizes)
- Display starting positions: 64 horizontal and 64 vertical locations
- Reverse video function: Characters can be inverted on a per character basis.
- Flashing types: Two types with periods of 0.5 and 1.0 second on a per character basis (duty fixed at 50%)
- Background color: One of eight colors (when internal synchronization used)
- External control input: Serial data input in 8-bit units
- Built-in horizontal/vertical sync separation circuit, AFC circuit, and synchronization detector
- Video output: Composite video signal output in NTSC, PAL, PAL-M, PAL-N, PAL60, NTSC4.43, or SECAM format

### Package Dimensions

unit: mm

#### 3196-DIP30SD

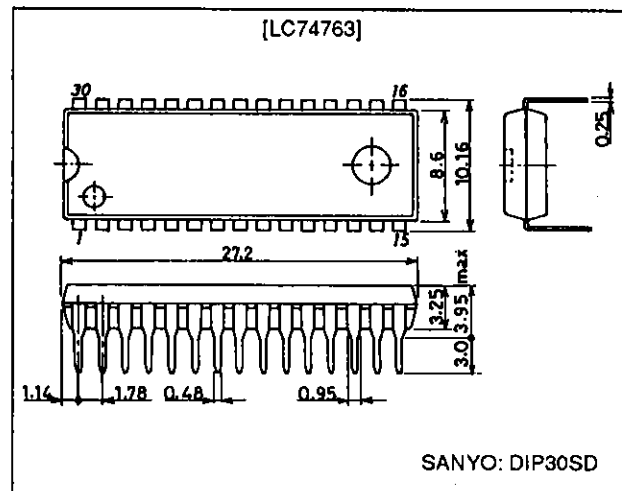

#### 3216A-MFP30S

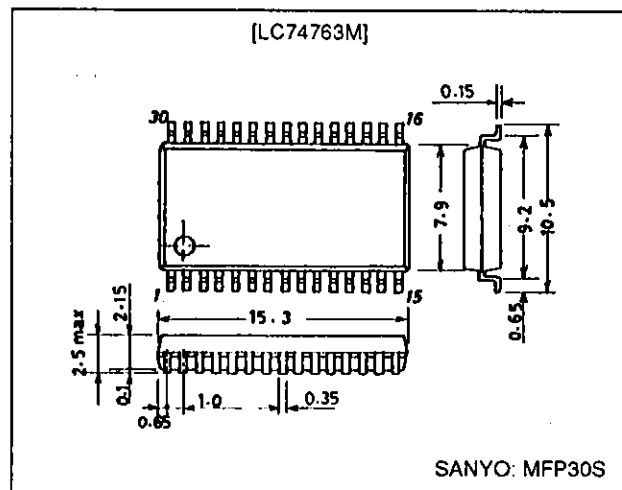

## O.S.D IC (74763M)

## Pin Functions (IC51)

Pin No.	Symbol	Function	Description
1	V <sub>SS</sub>	Ground	Ground connection
2	Xtal <sub>IN1</sub>	Crystal oscillator connection	Connection for the crystal and capacitor used to form the crystal oscillator that generates the internal synchronization signal. The oscillator can be selected with a command switch.
3	Xtal <sub>OUT1</sub>		
4	HSYNC <sub>OUT</sub>	Horizontal synchronization output	Outputs the horizontal synchronization signal (AFC). The output polarity can be selected (metal option). Also functions as general output port (command switch).
5	Xtal <sub>IN2</sub>	Crystal oscillator connection	Connection for the crystal and capacitor used to form the crystal oscillator that generates the internal synchronization signal.
6	Xtal <sub>OUT2</sub>		
7	VSYNC <sub>OUT</sub>	Vertical synchronization output	Outputs the vertical synchronization signal. The output polarity can be selected (metal option). Also functions as general output port (command switch).
8	$\overline{\text{CS}}$	Enable input	Enables/disables serial data input. Serial data is enabled when this pin is low (hysteresis input). Pull-up resistor built in (metal option).
9	SIN	Data input	Serial data input (hysteresis input). Pull-up resistor built in (metal option).
10	SCLK	Clock input	Clock input for serial data input (hysteresis input). Pull-up resistor built in (metal option).
11	SECAM	SECAM mode switch input/output (command switch)	During input, switches between SECAM and other modes. During output, functions as general output port or internal V output (command switch). Low = other modes, high = SECAM mode
12	$\overline{525/625}$	525/625 switch input/output (command switch)	During input, switches between 525 scan lines and 625 scan lines. During output, functions as general output port or character data output (command switch). Low = 525 lines, high = 625 lines
13	$\overline{\text{NTSC/PAL}}$	NTSC/PAL switch input/output (command switch)	Switches the color mode between NTSC and PAL. During output, functions as general output port or frame data output (command switch). Low = NTSC, high = PAL
14	$\overline{3.58/4.43}$	3.58/4.43 switch input/output (command switch)	Switch FSC between 3.58 MHz and 4.43 MHz. During output, functions as general output port or halftone output (command switch). Low = 3.58, high = 4.43
15	$\overline{\text{RST}}$	Reset input	System reset input pin, low is active (hysteresis input). Pull-up resistor built in (metal option).
16	CV <sub>OUT</sub>	Video signal output	Composite video output
17	V <sub>DD2</sub>	Power supply connection	Power supply connection for composite video signal level generation
18	CV <sub>IN</sub>	Video signal input	Composite video input
19	CV <sub>CR</sub>	Video signal input	SECAM chroma signal input
20	SYNC <sub>IN</sub>	Sync separator circuit input	Built-in sync separator circuit video signal input
21	SEP <sub>C</sub>	Sync separator circuit	Built-in sync separator circuit
22	V <sub>SS</sub>	Ground	Ground connection
23	PD <sub>OUT</sub>	Control voltage output	AFC control voltage output
24	AMP <sub>IN</sub>	AFC filter connection	Filter connection
25	AMP <sub>OUT</sub>		
26	FC	Control voltage input	AFC control voltage input
27	VCO <sub>IN</sub>	LC oscillator connection	VCO LC oscillator circuit coil and capacitor connection
28	VCO <sub>OUT</sub>		
29	SYNC <sub>DET</sub>	External synchronization signal detection output	Outputs the exclusive NOR of the horizontal synchronization signal (AFC) and CSYNC (sync separator). The output polarity can be selected (metal option). Also functions as general output port (command switch).
30	V <sub>DD1</sub>	Power supply connection	Power supply connection (+5 V: digital system power supply)

LC74763, 74763M

Pin Assignment

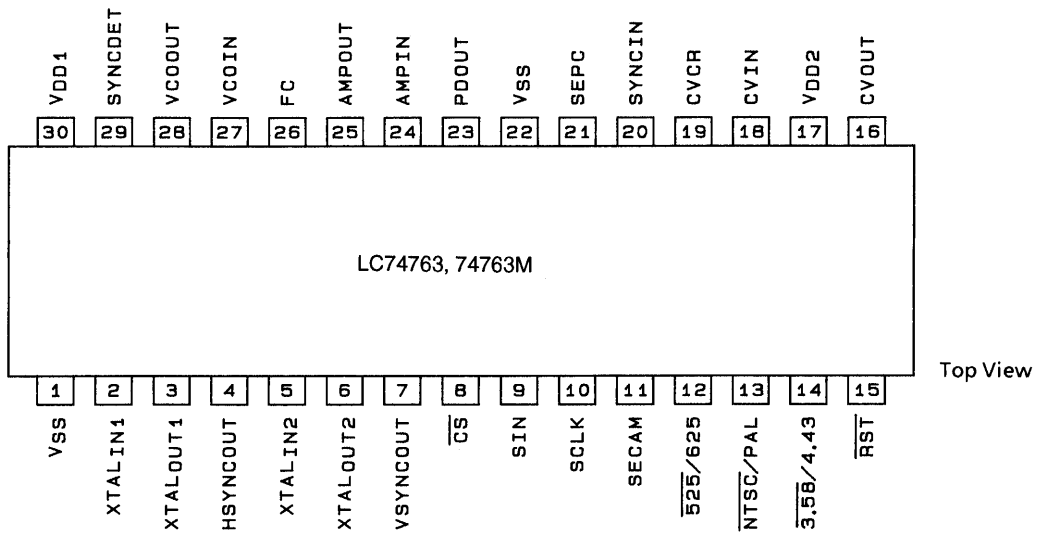

Top View

A03518

Top view

Serial Data Input Timing

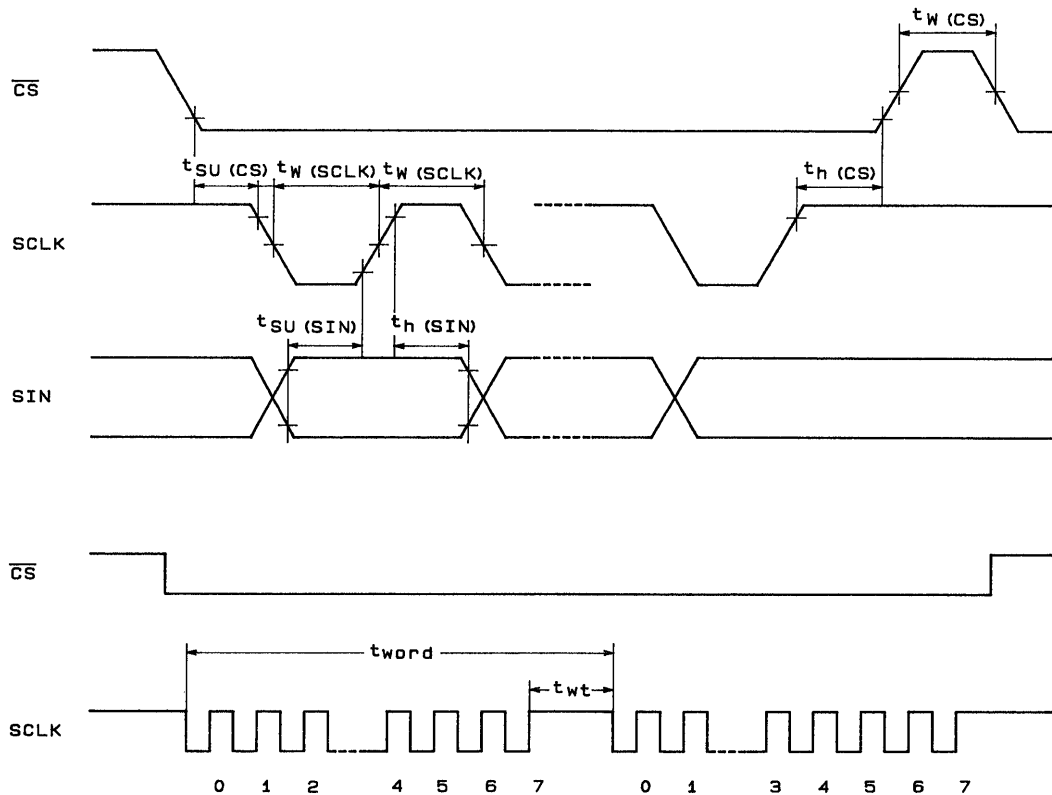

A03519

LC74763M BLOCK DIAGRAM

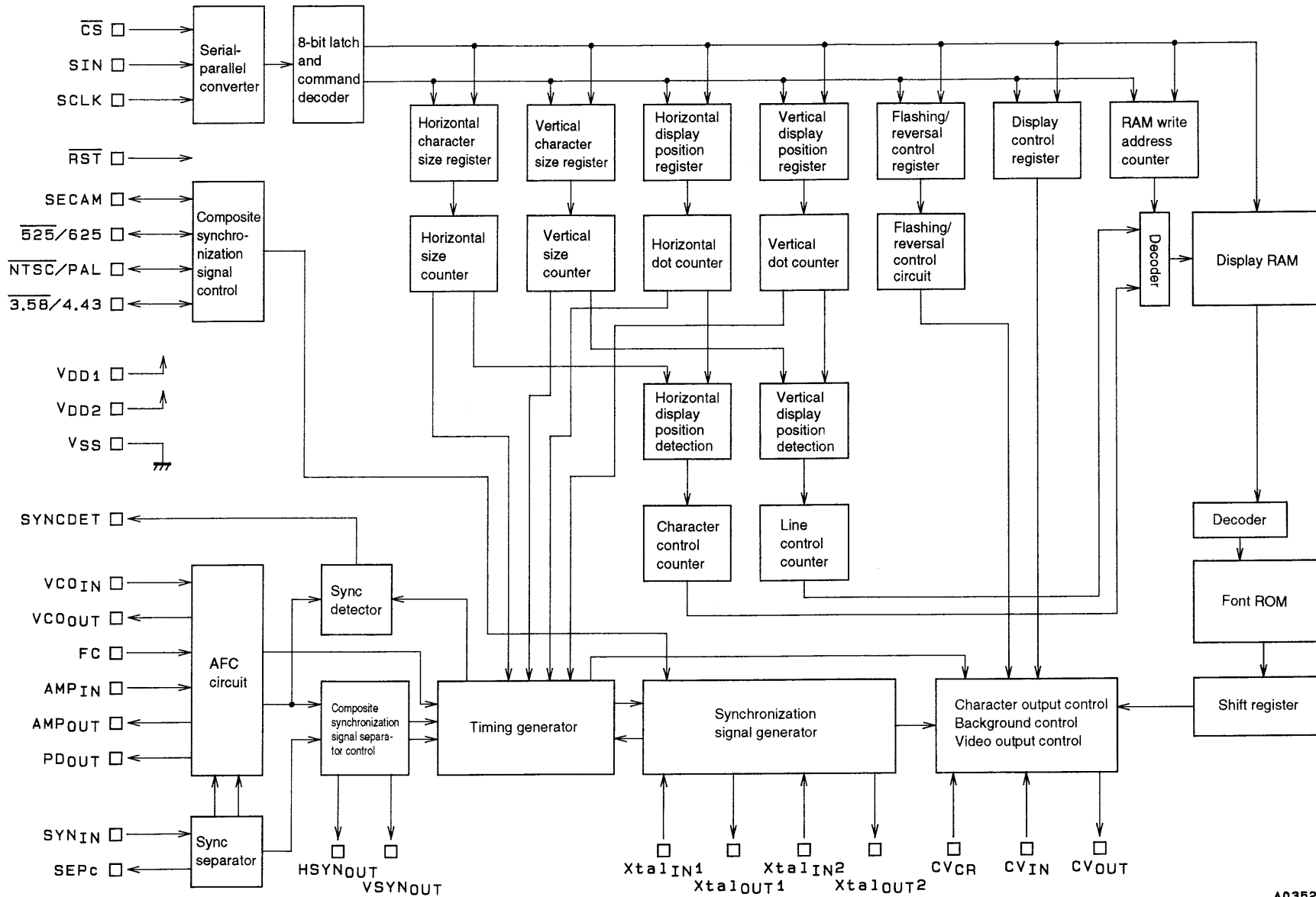

A03520

# U-COM IC PIN ASSIGNMENT & DESCRIPTIONS

## ■ PIN ASSIGNMENT (IC72)

(TOP VIEW)

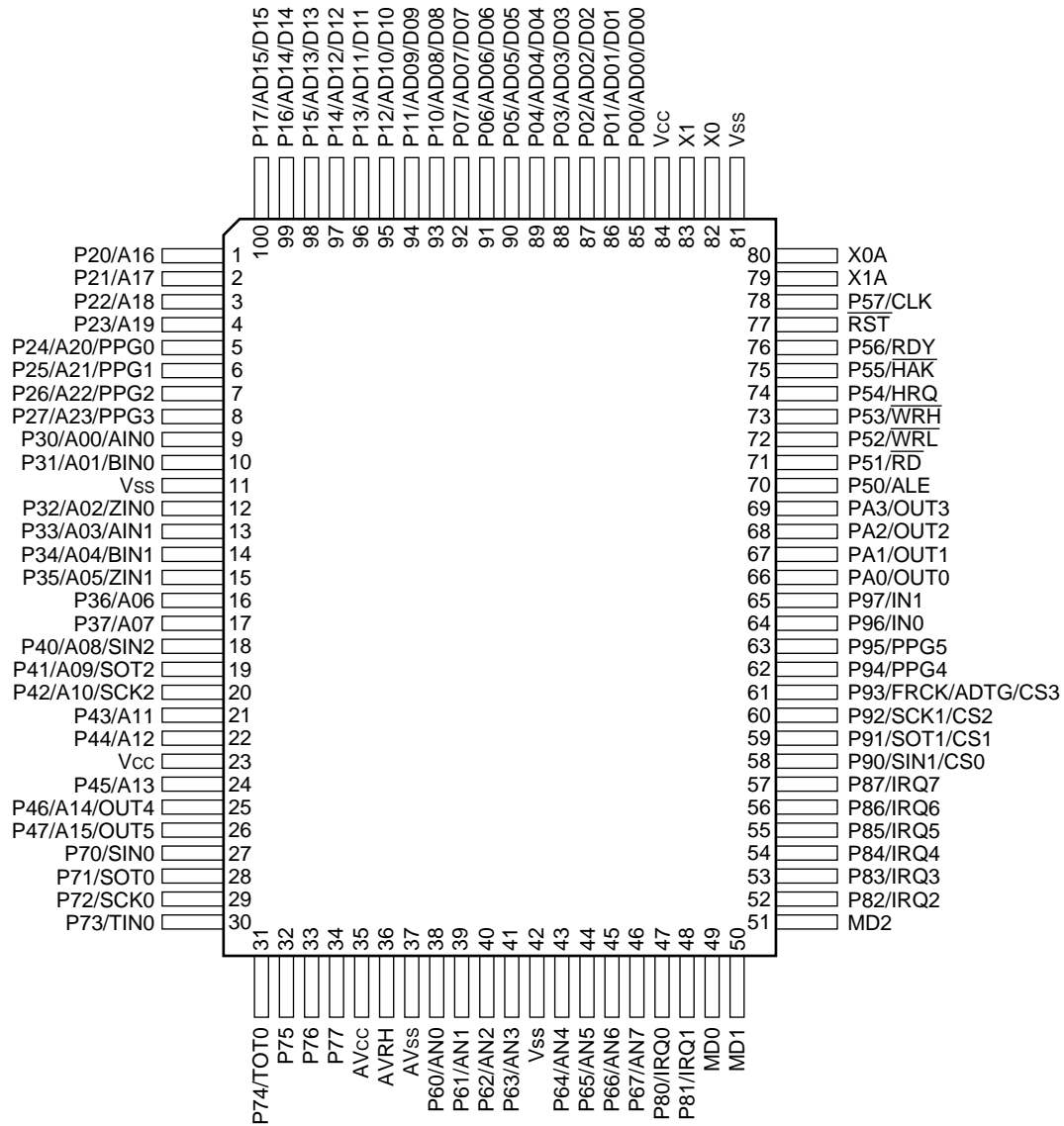

(FPT-100P-M06)



# MB90482

## ■ PIN DESCRIPTIONS (IC72)

Pin No.		Pin name	Circuit type	Function
LQFP*1	QFP*2			
80	82	X0	A	Oscillator pin
81	83	X1	A	Oscillator pin
78	80	X0A	A	32 kHz oscillator pin
77	79	X1A	A	32 kHz oscillator pin
75	77	$\overline{\text{RST}}$	B	Reset input pin
83 to 90	85 to 92	P00 to P07	C (CMOS)	This is a general purpose I/O port. A setting in the pull-up resistance setting register (RDR0) can be used to apply pull-up resistance (RD00-RD07 = "1") . (Disabled when pin is set for output.)
		AD00 to AD07		In multiplex mode, these pins function as the external address/ data bus low I/O pins.
		D00 to D07		In non-multiplex mode, these pins function as the external data bus low output pins.
91 to 98	93 to 100	P10 to P17	C (CMOS)	This is a general purpose I/O port. A setting in the pull-up resistance setting register (RDR1) can be used to apply pull-up resistance (RD10-RD17 = "1") . (Disabled when pin is set for output.)
		AD08 to AD15		In multiplex mode, these pins function as the external address/ data bus high I/O pins.
		D08 to D15		In non-multiplex mode, these pins function as the external data bus high output pins.
99, 100, 1,2	1 to 4	P20 to P23	E (CMOS/H)	This is a general purpose I/O port. When the bits of external address output control register (HACR) are set to "1" in external bus mode, these pins function as general purpose I/O ports.
		A16 to A19		When the bits of external address output control register (HACR) are set to "0" in multiplex mode, these pins function as address high output pins (A16-A19).
		A16 to A19		When the bits of external address output control register (HACR) are set to "0" in non-multiplex mode, these pins function as address high output pins (A16-A19).
3 to 6	5 to 8	P24 to P27	E (CMOS/H)	This is a general purpose I/O port. When the bits of external address output control register (HACR) are set to "1" in external bus mode, these pins function as general purpose I/O ports.
		A20 to A23		When the bits of external address output control register (HACR) are set to "0" in multiplex mode, these pins function as address high output pins (A20-A23).
		A20 to A23		When the bits of external address output control register (HACR) are set to "0" in non-multiplex mode, these pins function as address high output pins (A20-A23).
		PPG0 to PPG3		PPG timer output pins.

(Continued)

**MB90482**

Pin No.		Pin name	Circuit type	Function
LQFP*1	QFP*2			
7	9	P30	E (CMOS/H)	This is a general purpose I/O port.
		A00		In non-multiplex mode, this pin functions as an external address pin.
		AIN0		8/16-bit up/down timer input pin (channel 0) .
8	10	P31	E (CMOS/H)	This is a general purpose I/O port.
		A01		In non-multiplex mode, this pin functions as an external address pin.
		BIN0		8/16-bit up/down counter input pin (channel0) .
10	12	P32	E (CMOS/H)	This is a general purpose I/O port.
		A02		In non-multiplex mode, this pin functions as an external address pin.
		ZIN0		8/16-bit up/down counter input pin (channel 0)
11	13	P33	E (CMOS/H)	This is a general purpose I/O port.
		A03		In non-multiplex mode, this pin functions as an external address pin.
		AIN1		8/16-bit up/down counter input pin (channel 1) .
12	14	P34	E (CMOS/H)	This is a general purpose I/O port.
		A04		In non-multiplex mode, this pin functions as an external address pin.
		BIN1		8/16-bit up/down counter input pin (channel 1) .
13	15	P35	E (CMOS/H)	This is a general purpose I/O port.
		A05		In non-multiplex mode, this pin functions as an external address pin.
		ZIN1		8/16-bit up/down counter input pin (channel 1)
14 15	16 17	P36, P37 A06, A07	D*3 (CMOS)	This is a general purpose I/O port. In non-multiplex mode, this pin functions as an external address pin.
16	18	P40	G (CMOS/H)	This is a general purpose I/O port.
		A08		In non-multiplex mode, this pin functions as an external address pin.
		SIN2		Simple serial I/O input pin.
17	19	P41	F (CMOS)	This is a general purpose I/O port.
		A09		In non-multiplex mode, this pin functions as an external address pin.
		SOT2		Simple serial I/O output pin.
18	20	P42	G (CMOS/H)	This is a general purpose I/O port.
		A10		In non-multiplex mode, this pin functions as an external address pin.
		SCK2		Simple serial I/O clock input/output pin.

*(Continued)*

# MB90482

Pin No.		Pin name	Circuit type	Function
LQFP*1	QFP*2			
19 20	21 22	P43, P44	F (CMOS)	This is a general purpose I/O port.
		A11, A12		In non-multiplex mode, this pin functions as an external address pin.
22	24	P45	F*4 (CMOS)	This is a general purpose I/O port.
		A13		In non-multiplex mode, this pin functions as an external address pin.
23 24	25 26	P46, P47	F (CMOS)	This is a general purpose I/O port.
		A14, A15		In non-multiplex mode, this pin functions as an external address pin.
		OUT4/OUT5		Output compare event output pins.
68	70	P50	D (CMOS)	This is a general purpose I/O port. In external bus mode, this pin functions as the ALE pin.
		ALE		In external bus mode, this pin functions as the address load enable (ALE) signal pin.
69	71	P51	D (CMOS)	This is a general purpose I/O port. In external bus mode, this pin functions as the $\overline{RD}$ pin.
		$\overline{RD}$		In external bus mode, this pin functions as the read strobe output ( $\overline{RD}$ ) signal pin.
70	72	P52	D (CMOS)	This is a general purpose I/O port. In external bus mode, when the WRE pin in the EPCR register is set to "1", this pin functions as the $\overline{WRL}$ pin.
		$\overline{WRL}$		In external bus mode, this pin functions as the lower data write strobe output ( $\overline{WRL}$ ) pin. When the WRE bit in the EPCR register is set to "0", this pin functions as a general purpose I/O port.
71	73	P53	D (CMOS)	This is a general purpose I/O port. In external bus mode with 16-bit bus width, when the WRE bit in the EPCR register is set to "1", this pin functions as the $\overline{WRH}$ pin.
		$\overline{WRH}$		In external bus mode with 16-bit bus width, this pin functions as the upper data write strobe output ( $\overline{WRH}$ ) pin. When the WRE bit in the EPCR register is set to "0", this pin functions as a general purpose I/O port.
72	74	P54	D (CMOS)	This is a general purpose I/O port. In external bus mode, when the HDE bit in the EPCR register is set to "1", this pin functions as the HRQ pin.
		HRQ		In external bus mode, this pin functions as the hold request input (HRQ) pin. When the HDE bit in the EPCR register is set to "0", this pin functions as a general purpose I/O port.
73	75	P55	D (CMOS)	This is a general purpose I/O port. In external bus mode, when the HDE bit in the EPCR register is set to "1", this pin functions as the $\overline{HAK}$ pin.
		$\overline{HAK}$		In external bus mode, this pin functions as the hold acknowledge ( $\overline{HAK}$ ) pin. When the HDE bit in the EPCR register is set to "0", this pin functions as a general purpose I/O port.

(Continued)

**MB90482**

Pin No.		Pin name	Circuit type	Function
LQFP*1	QFP*2			
74	76	P56	D (CMOS)	This is a general purpose I/O port. In external bus mode, when the RYE bit in the EPCR register is set to "1", this pin functions as the RDY pin.
		RDY		In external bus mode, this pin functions as the external ready (RDY) input pin. When the RYE bit in the EPCR register is set to "0", this pin functions as a general purpose I/O port.
76	78	P57	D (CMOS)	This is a general purpose I/O port. In external bus mode, when the CKE bit in the EPCR register is set to "1", this pin functions as the CLK pin.
		CLK		In external bus mode, this pin functions as the machine cycle clock (CLK) output pin. When the CKE bit in the EPCR register is set to "0", this pin functions as a general purpose I/O port.
36 to 39	38 to 41	P60 to P63	H (CMOS)	These are general purpose I/O ports.
		AN0 to AN3		These are the analog input pins.
41 to 44	43 to 46	P64 to P67	H (CMOS)	These are general purpose I/O ports.
		AN4 to AN7		These are the analog input pins.
25	27	P70	G (CMOS/H)	This is a general purpose I/O port.
		SIN0		This is the UART data input pin.
26	28	P71	F (CMOS)	This is a general purpose I/O port.
		SOT0		This is the UART data output pin.
27	29	P72	G (CMOS/H)	This is a general purpose I/O port.
		SCK0		This is the UART clock I/O pin.
28	30	P73	G (CMOS/H)	This is a general purpose I/O port.
		TIN0		This is the 16-bit reload timer event input pin.
29	31	P74	F (CMOS)	This is a general purpose I/O port.
		TOT0		This is the 16-bit reload timer output pin.
30	32	P75	F*4 (CMOS)	This is a general purpose I/O port.
31	33	P76	F*5 (CMOS)	This is a general purpose I/O port.
32	34	P77	F*5 (CMOS)	This is a general purpose I/O port.
45, 46	47, 48	P80, P81	E (CMOS/H)	These are general purpose I/O ports.
		IRQ0, IRQ1		External interrupt input pins.
50 to 55	52 to 57	P82 to P87	E (CMOS/H)	These are general purpose I/O ports.
		IRQ2 to IRQ7		External interrupt input pins.

*(Continued)*

**MB90482**

(Continued)

Pin No.		Pin name	Circuit type	Function
LQFP*1	QFP*2			
56	58	P90	E (CMOS/H)	This is a general purpose I/O port.
		SIN1		Simple serial I/O data input pin.
		CS0		Chip select 0.
57	59	P91	D (CMOS)	This is a general purpose I/O port.
		SOT1		Simple serial I/O data output pin.
		CS1		Chip select 1.
58	60	P92	E (CMOS/H)	This is a general purpose I/O port.
		SCK1		Simple serial I/O data input/output pin.
		CS2		Chip select 2.
59	61	P93	E (CMOS/H)	This is a general purpose I/O port.
		FRCK		When the free run timer is in use, this pin functions as the external clock input pin.
		ADTG		When the A/D converter is in use, this pin functions as the external trigger input pin.
		CS3		Chip select 3.
60	62	P94	D (CMOS)	This is a general purpose I/O port.
		PPG4		PPG timer output pin.
61	63	P95	D (CMOS)	This is a general purpose I/O port.
		PPG5		PPG timer output pin.
62	64	P96	E (CMOS/H)	This is a general purpose I/O port.
		IN0		Input capture channel 0 trigger input pin.
63	65	P97	E (CMOS/H)	This is a general purpose I/O port.
		IN1		Input capture channel 1 trigger input pin.
64 to 67	66 to 69	PA0 to PA3	D (CMOS)	These are general purpose I/O ports.
		OUT0 to OUT3		Output compare event output pins.
33	35	AV <sub>cc</sub>	—	A/D converter power supply pin.
34	36	AVRH	—	A/D converter external reference voltage supply pin.
35	37	AV <sub>ss</sub>	—	A/D converter power supply pin.
47 to 49	49 to 51	MD0 to MD2	J (CMOS/H)	Operating mode selection input pins.
21, 82	23, 84	V <sub>cc</sub>	—	3.3 V ± 0.3 V power supply pins (V <sub>cc3</sub> ) .
9, 40, 79	11, 42, 81	V <sub>ss</sub>	—	Power supply input pins (GND) .

\*1 : LQFP : FPT-100P-M05

\*2 : QFP : FPT-100P-M06

\*3 : The circuit type of MB90V480 is E (CMOS/H).

\*4 : The circuit type of MB90V480 is G (CMOS/H).

\*5 : The circuit type of MB90V480 is I (NMOS/H)

**NJM2068M (OP - AMP)**



**NJM2068**

**LOW-NOISE DUAL OPERATIONAL AMPLIFIER**

■ **GENERAL DESCRIPTION**

The NJM2068 is a high performance, low noise dual operational amplifier. This amplifier features popular pin-out, superior noise performance, and superior total harmonic distortion. This amplifier also features guaranteed noise performance with substantially higher gain-bandwidth product and slew rate which far exceeds that of the 4558 type amplifier. The specially designed low noise input transistors allow the NJM2068 to be used in very low noise signal processing applications such as audio preamplifiers and servo error amplifier.

■ **PACKAGE OUTLINE**

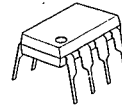

NJM2068D



NJM2068M



NJM2068V

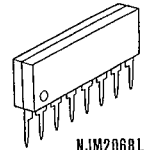

NJM2068L

■ **FEATURES**

- Operating Voltage  $(\pm 4V \sim \pm 18V)$
- Low Total Harmonic Distortion  $(0.001\% \text{ typ.})$
- Low Noise Voltage  $(\text{FLAT} + \text{JISA}, 0.56 \mu\text{V typ.})$
- High Slew Rate  $(6V/\mu\text{s typ.})$
- Unity Gain Bandwidth  $(27\text{MHz @ } f=10\text{kHz})$
- Package Outline DIP8, DMP8, SIP8, SSOP8
- Bipolar Technology

■ **PIN CONFIGURATION**

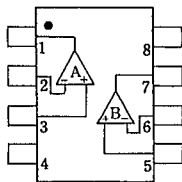

NJM2068D  
NJM2068M  
NJM2068V

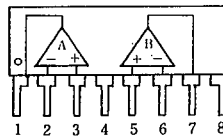

NJM2068L

**PIN FUNCTION**

1. A OUTPUT
2. A-INPUT
3. A+INPUT
4. V-
5. B+INPUT
6. B-INPUT
7. B OUTPUT
8. V+

■ **EQUIVALENT CIRCUIT (1/2 Shown)**

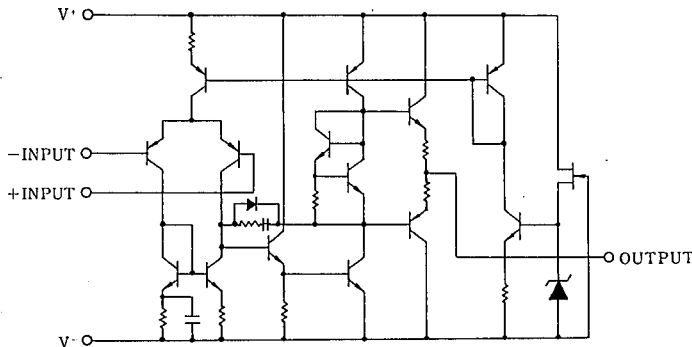

# NJM2296

## 5-INPUT 3-OUTPUT VIDEO SW

### GENERAL DESCRIPTION

The NJM2296 is a 5-input 3-output video switch.

Its switches select one from five signals received from VTR, TV, TV GAME and others.

This IC is designed for audio items, such as AV amplifier and receivers, and others

### PACKAGE OUTLINE

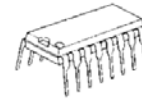

NJM2296D

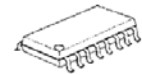

NJM2296M

### FEATURES

- 5-input 3-output
- Operating Voltage  $\pm 4.0$  to  $\pm 6.5V$
- Operating Current  $\pm 31mA$  typ. at  $V_{CC} = \pm 5V$
- Crosstalk  $-65dB$  typ.
- Internal 6dB Amplifier
- Internal  $75\Omega$  Driver
- Bipolar Technology
- Package Outline DIP16, DMP16

### BLOCK DIAGRAM

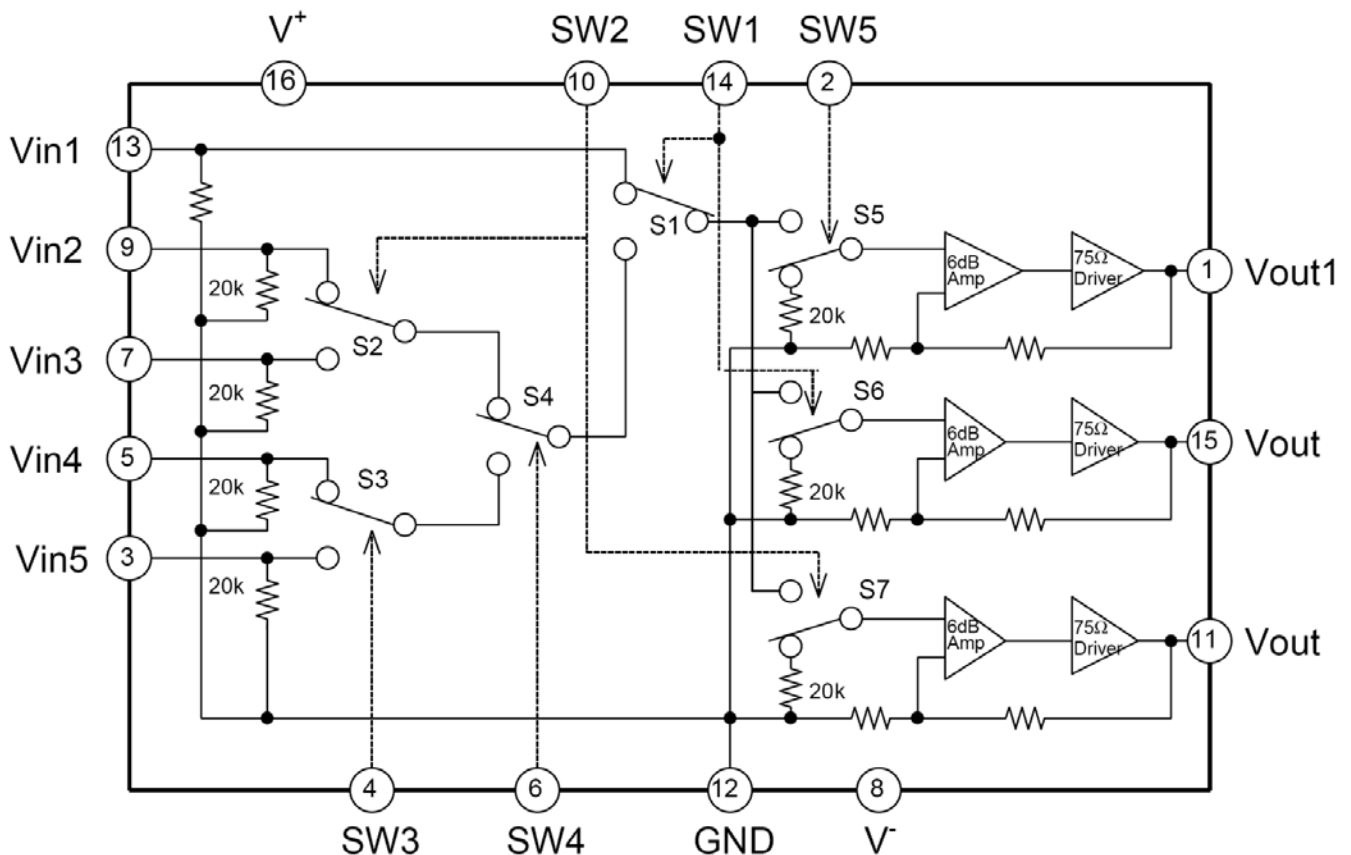



# NJM2581

## DUAL SUPPLY WIDE BAND 3ch VIDEO AMPLIFIER

### ■ GENERAL DESCRIPTION

The **NJM2581** is a dual supply voltage wide band 3ch video amplifier. It is suitable for Y, Pb, and Pr signal because frequency range is 50MHz.

The **NJM2581** is suitable for Set Top Box, AV amplifier, and other high quality AV systems.

### ■ PACKAGE OUTLINE

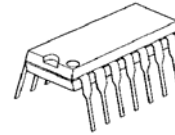

NJM2581D

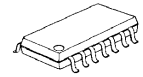

NJM2581M

### ■ FEATURES

- Operating Voltage                     $\pm 4.5$  to  $\pm 5.5$ V
- Wide frequency range                50MHz at 0dB typ.
- Internal 6dB Amplifier
- Internal 75 $\Omega$  Driver Circuit (2-system drive)
- Power Save Circuit
- Bipolar Technology
- Package Outline                        DIP14, DMP14

### ■ BLOCK DIAGRAM

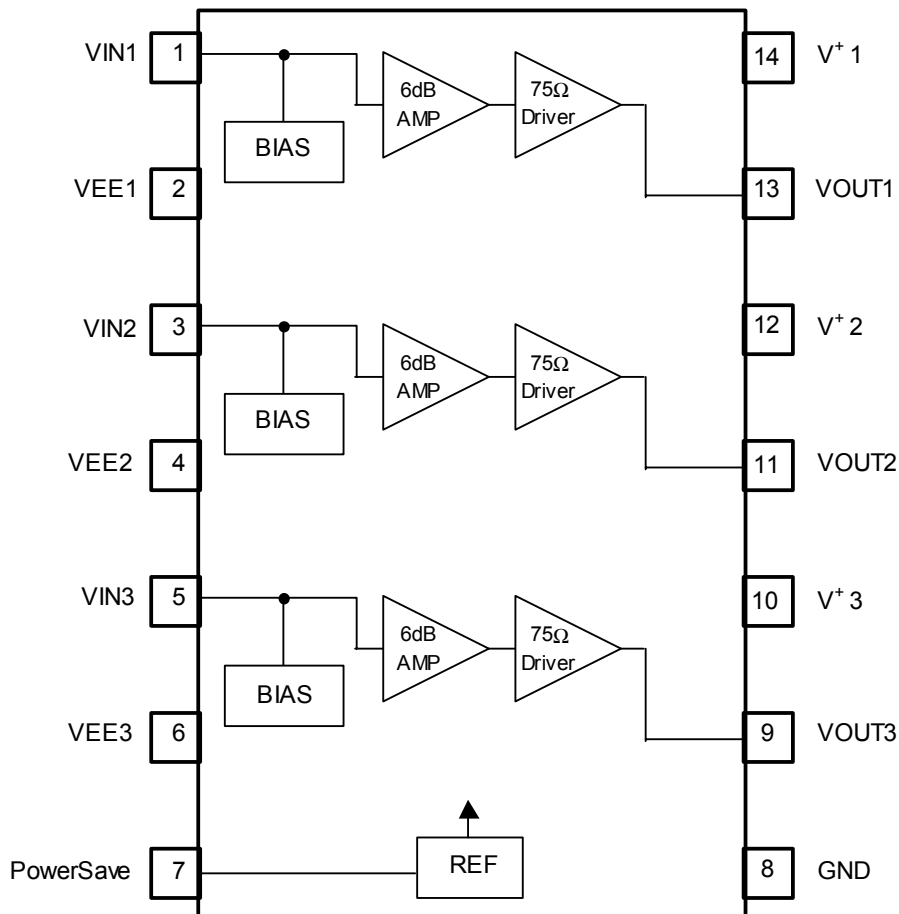



# NJM2581

## ■ EQUIVALENT CIRCUIT

PIN No.	PIN NAME	FUNCTION	INSIDE EQUIVALENT CIRCUIT
1 3 5	VIN1 VIN2 VIN3	Input	
13 11 9	VOUT1 VOUT2 VOUT3	Output	
7	PowerSave	Power Save	
14 12 10	V <sup>+</sup> 1 V <sup>+</sup> 2 V <sup>+</sup> 3	V+	_____
2 4 6	VEE1 VEE2 VEE3	V-	_____
8	GND	GND	_____



IC86

NJM4556A

DUAL HIGH CURRENT OPERATIONAL AMPLIFIER

■ GENERAL DESCRIPTION

The NJM4556A integrated circuit is a high-gain, high output current dual operational amplifier capable of driving  $\pm 70\text{mA}$  into  $150\ \Omega$  loads ( $\pm 10.5\text{V}$  output voltage), and operating low supply voltage ( $V^+/V^- = \pm 2\text{V} \sim$ ).

The NJM4556A combines many of the fetures of the popular NJM4558 as well as having the capability of driving  $150\ \Omega$  loads. In addition, the wide band-width, low noise, high slew rate and low distortion of the NJM4556A make it ideal for many audio, telecommuncations and instrumentation applications.

■ FEATURES

- Operating Voltage ( $\pm 2\text{V} \sim \pm 18\text{V}$ )
- High Output Current ( $I_o = 70\text{mA}$ )
- Slew Rate ( $3\text{V}/\mu\text{s}$  typ.)
- Gain Band Width Product ( $8\text{MHz}$  typ.)
- Package Outline DIP8, DMP8, SIP8, SSOP8
- Bipolar Technology

■ PACKAGE OUTLINE

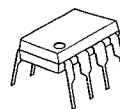

NJM4556AD



NJM4556AM

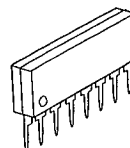

NJM4556AL



NJM4556AV

■ PIN CONFIGURATION

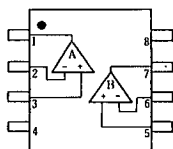

NJM4556AD.  
NJM4556AM  
NJM4556AV

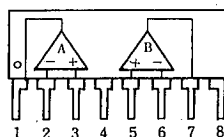

NJM4556AL

PIN FUNCTION

1. A OUTPUT
2. A-INPUT
3. A+INPUT
4. V-
5. B+INPUT
6. B-INPUT
7. B OUTPUT
8. V+

■ EQUIVALENT CIRCUIT (1/2 Shown)

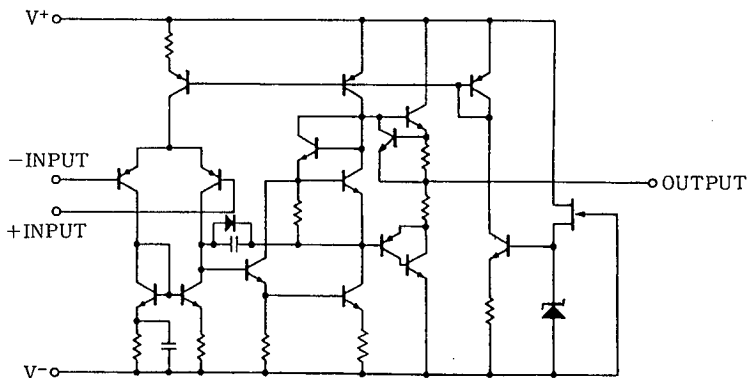

### PIN CONFIGURATION

• TO-92

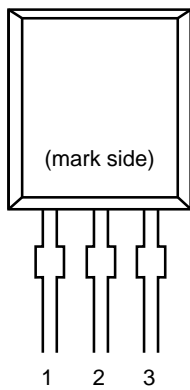

• SOT-89

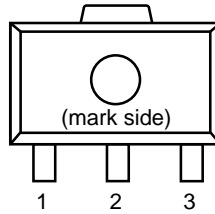

• SOT-23-5

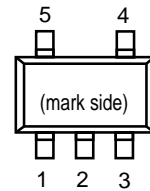

IC87 RE5VL28CATZ  
IC85 RH5VT18C

IC , RESET  
I.C , RESET

### PIN DESCRIPTION

• TO-92

Pin No	Symbol
1	OUT
2	VDD
3	GND

• SOT-89

Pin No	Symbol
1	OUT
2	VDD
3	GND

• SOT-23-5

Pin No	Symbol
1	OUT
2	VDD
3	GND
4	NC
5	NC

### BLOCK DIAGRAMS

• Nch Open Drain Output (R>5VL×A)

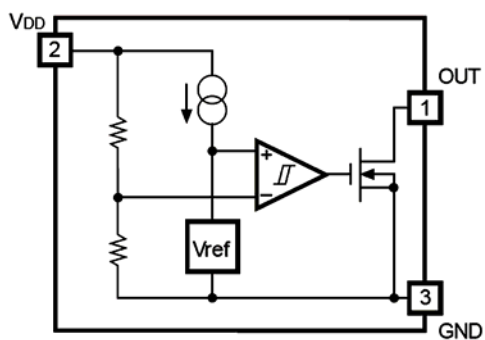

• CMOS Output (R>5VL×C)

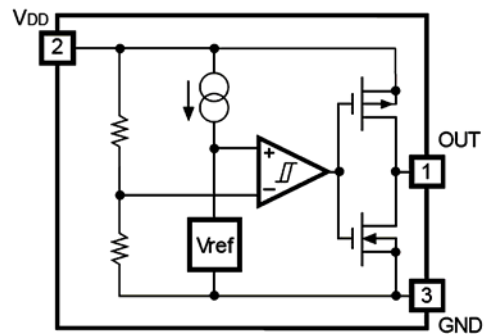

**BLOCK DIAGRAM (IC74)**

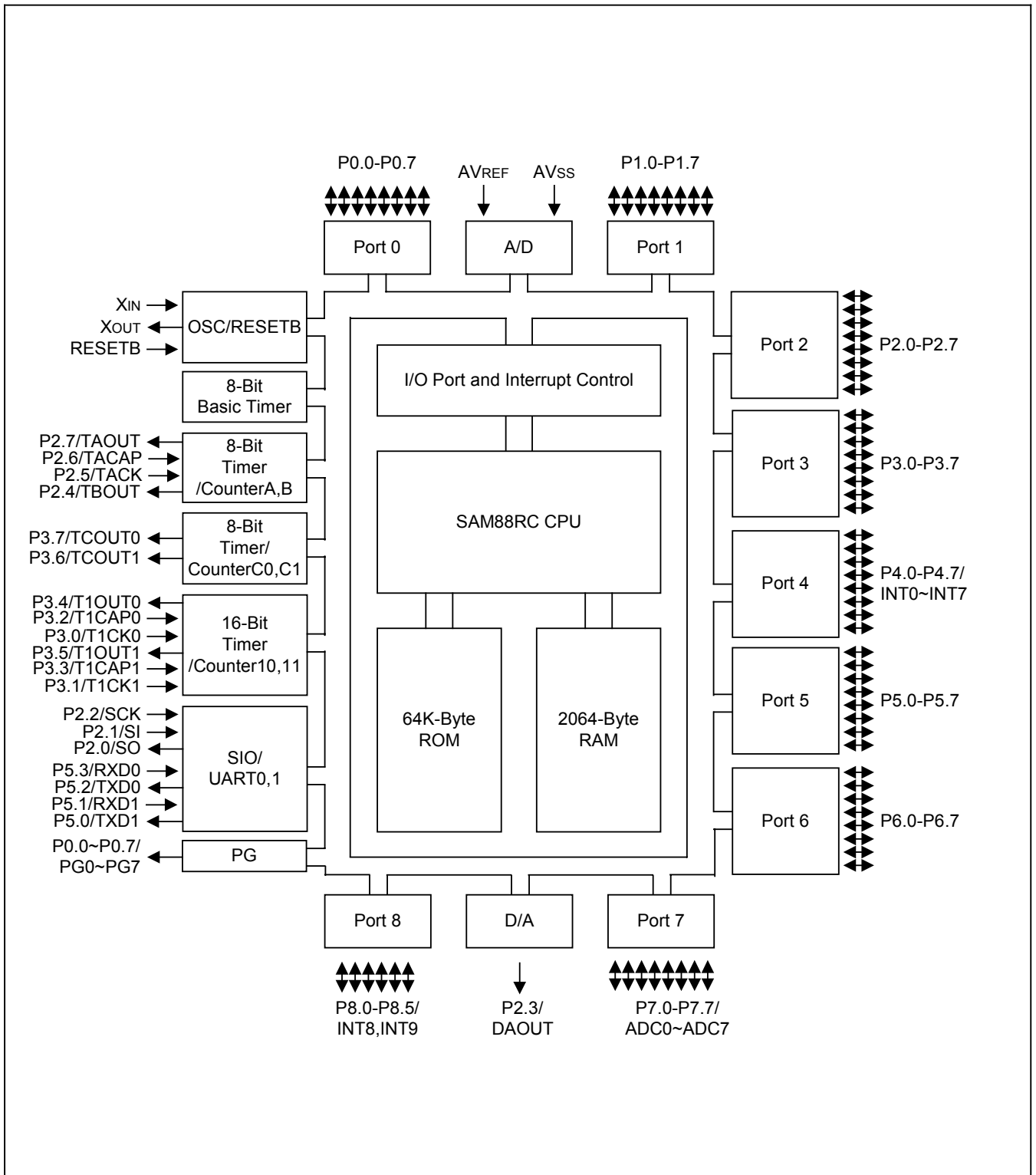

**Figure 1-1. S3C84BB/F84BB Block Diagram**

**PIN ASSIGNMENT (IC74)**

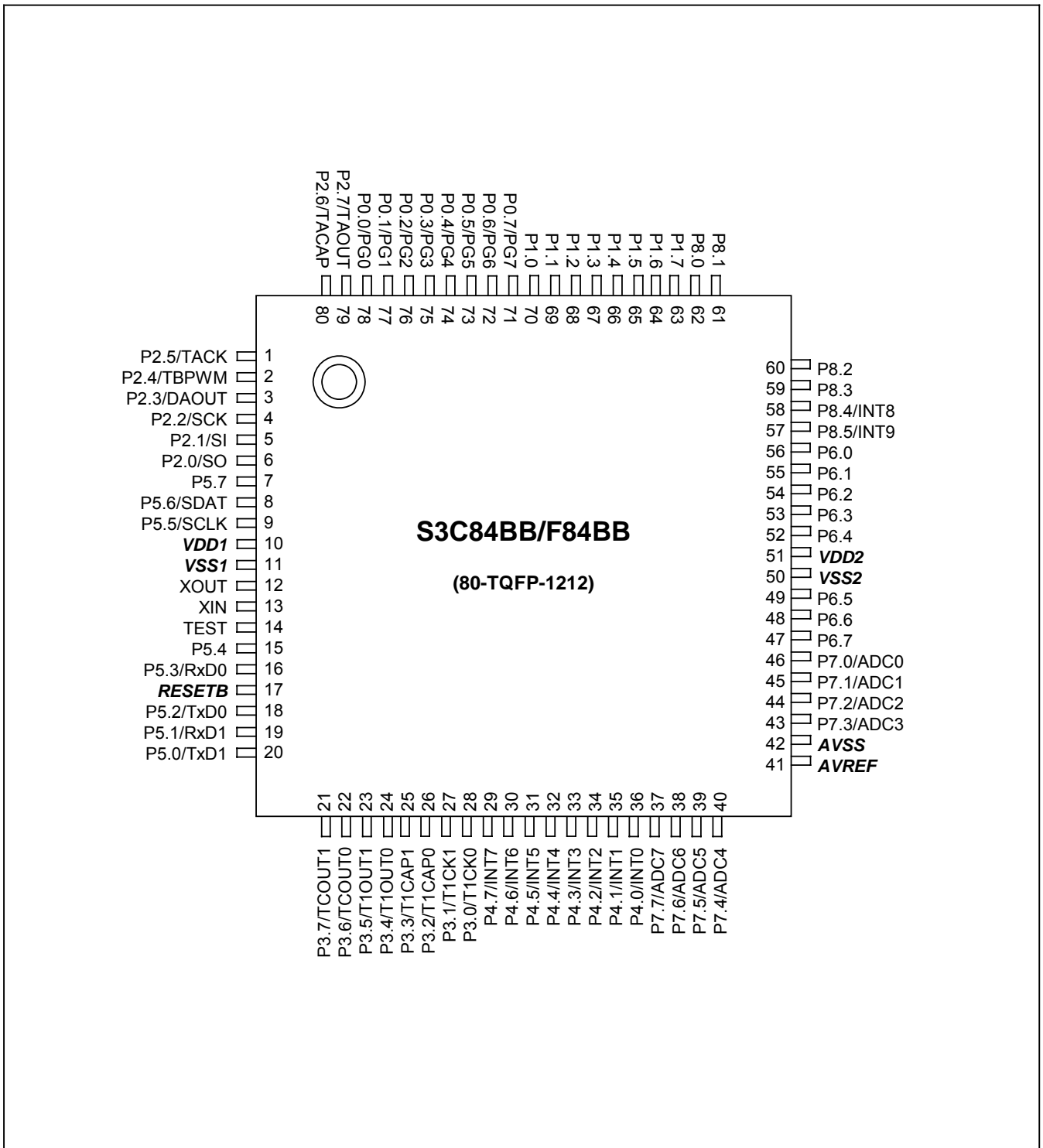

Figure 1-3. S3C84BB/F84BB Pin Assignment (80-TQFP)

## PRODUCT OVERVIEW

## S3C84BB/F84BB

## PIN DESCRIPTIONS (IC74)

Table 1-1. S3C84BB/F84BB Pin Descriptions (80-QFP)

Pin Name	Pin Type	Pin Description	Circuit Type	Pin Number	Share Pins
P0.0 - P0.7	I/O	Bit programmable port; input or output mode selected by software; input or push-pull output. Software assignable pull-up. Alternately, P0.0-P0.7 can be used as the PG output port (PG0-PG7).	D	80-73	PG0-PG7
P1.0 - P1.7	I/O	Bit programmable port; input or output mode selected by software; input or push-pull output. Software assignable pull-up.	D	72-65	
P2.0 - P2.7	I/O	Bit programmable port; input or output mode selected by software; input or push-pull output. Software assignable pull-up. Alternately, P2.0~P2.7 can be used as I/O for TIMERA, TIMERB, D/A, SIO	D,D-2	8-1	SO SI SCK DAOUT TBPWM TACK TACAP TAOUT
P3.0 - P3.7	I/O	Bit programmable port; input or output mode selected by software; input or push-pull output. Software assignable pull-up. Alternately, P3.0~P3.7 can be used as I/O for TIMERC0/C1, TIMER10/11	D	30-23	T1CK0 T1CK1 T1CAP0 T1CAP1 T1OUT0 T1OUT1 TCOUT0 TCOUT1

## S3C84BB/F84BB

## PRODUCT OVERVIEW

Table 1-1. S3C84BB/F84BB Pin Descriptions (80-QFP) (Continued)

Pin Name	Pin Type	Pin Description	Circuit Type	Pin Number	Share Pins
P4.0 - P4.7	I/O	Bit programmable port; input or output mode selected by software; input or push-pull output. Software assignable pull-up. P4.0-P4.7 can alternately be used as inputs for external interrupts INT0-INT7, respectively (with noise filters and interrupt controller)	D-1	38-31	INT0-INT7
P5.0 - P5.7	I/O	Bit programmable port; input or output mode selected by software; input or push-pull output. Software assignable pull-up. Alternately, P5.0~P5.3 can be used as I/O for serial por, UART0, UART1, respectively.	G	22-17,11-9	TxD1 RxD1 TxD0 RxD0
P6.0 - P6.7	O	N-channel, open-drain output only port.	F	58-54,51-49	
P7.0 - P7.7	I	General-purpose digital input ports. Alternately used as analog input pins for A/D converter modules.	E	48-45,42-39	ADC0-ADC7
P8.0 - P8.5	I/O	Bit programmable port; input or output mode selected by software; input or push-pull output. Software assignable pull-up. P8.4, P8.5 can alternately be used as inputs for external interrupts INT8, INT9, respectively (with noise filters and interrupt controller)	D,D-1	64-59	INT8,INT9

## PRODUCT OVERVIEW

## S3C84BB/F84BB

Table 1-1. S3C84BB/F84BB Pin Descriptions (80-QFP) (Continued)

Pin Name	Pin Type	Pin Description	Circuit Type	Pin Number	Share Pins
AD0 - AD7	I	Analog input pins for A/D converter module. Alternatively used as general-purpose digital input port 7.	E	48–45 42–39	P7.0–P7.7
AVREF, AVSS	-	A/D converter reference voltage and ground	-	43, 44	-
RxD0, RxD1	I/O	Serial data RxD pin for receive input and transmit output (mode 0)	D	18, 21	P5.3, P5.1
TxD0, TxD1	O	Serial data TxD pin for transmit output and shift clock input (mode 0)	D	20, 22	P5.2, P5.0
TACK	I	External clock input pins for timer A	D	3	P2.5
TACAP	I	Capture input pins for timer A	D	2	P2.6
TAOUT	O	Pulse width modulation output pins for timer A	D	1	P2.7
TBPWM	O	Carrier frequency output pins for timer B	D	4	P2.4
TCOUT0 TCOUT1	O	Timer C 8-bit PWM mode output or counter match toggle output pins	D	24,23	P3.6,P3.7
T1CK0 T1CK1	I	External clock input pins for timer 1	D	39,30	P3.0,P3.1
T1CAP0 T1CAP1	I	Capture input pins for timer 1	D	28,27	P3.2,P3.3
T1OUT0 T1OUT1	O	Timer 1 16-bit PWM mode output or counter match toggle output pins	D	26,25	P3.4,P3.5
SI,SO,SCK	I/O	Synchronous SIO pins	D	7,8,9	P2.1,P2.0, P2.2
RESETB	I	System reset pin (pull-up resistor: 240 k $\Omega$ )	B	19	-
TEST	I	Pull – down register connected internally	-	16	-
VDD1, VDD2, VSS1, VSS2	-	Power input pins	-	12,53, 13,52	-
XIN, XOUT	-	Main oscillator pins	-	15,14	-



# TC9162AF (FUNCTION/INPUT :

## ■ BLOCK DIAGRAM

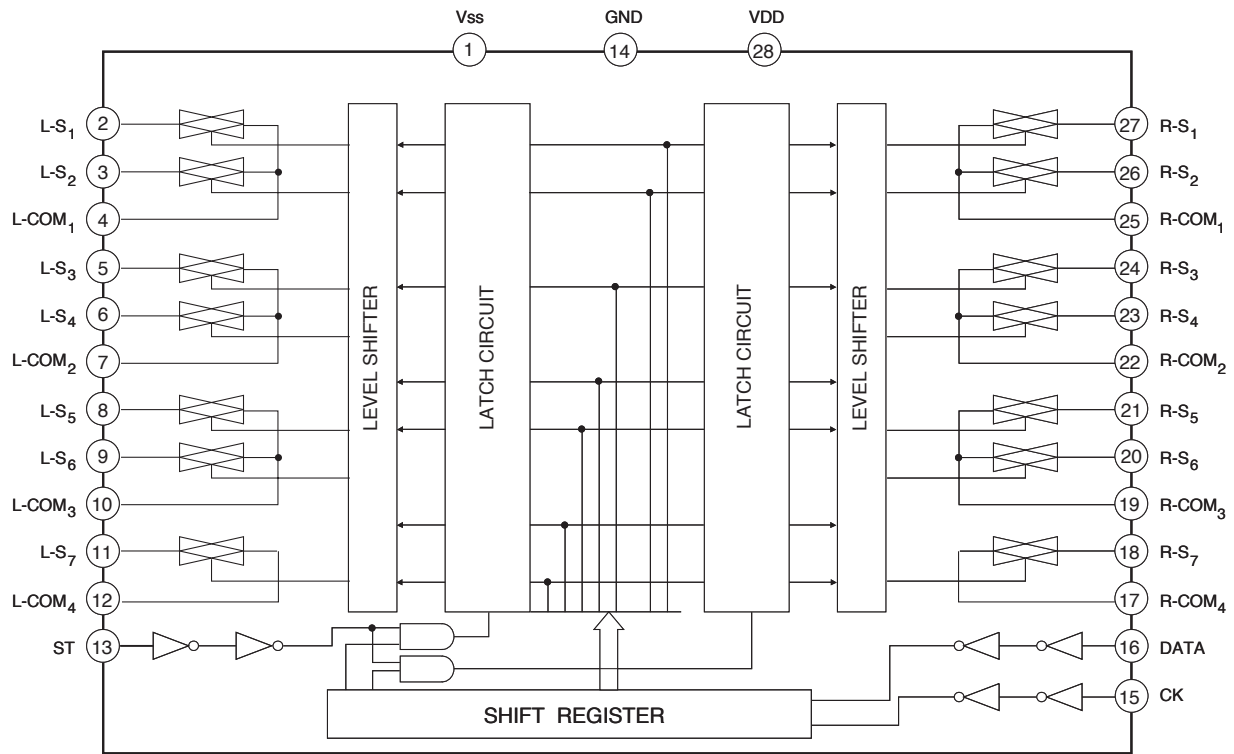

### TC9164AF (FUNCTION/INPUT) : IC23

#### ■ BLOCK DIAGRAM

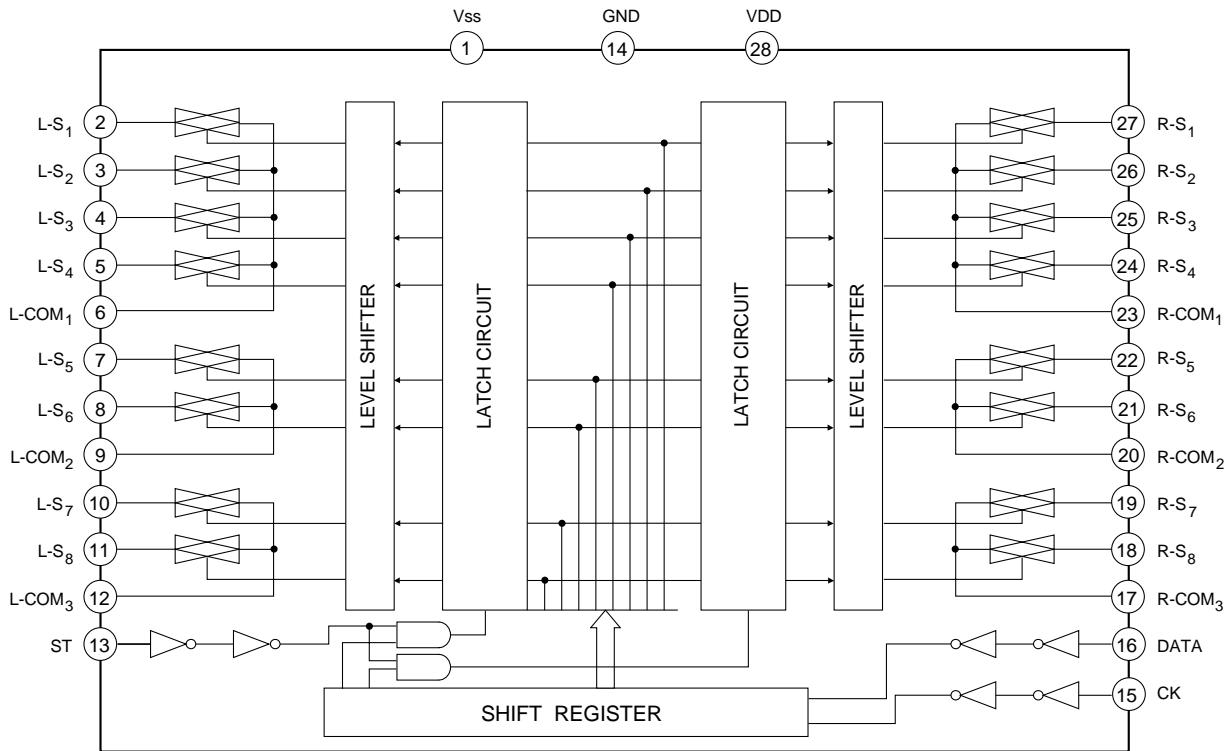

### TC9163AF (FUNCTION/INPUT) : IC24

#### ■ BLOCK DIAGRAM

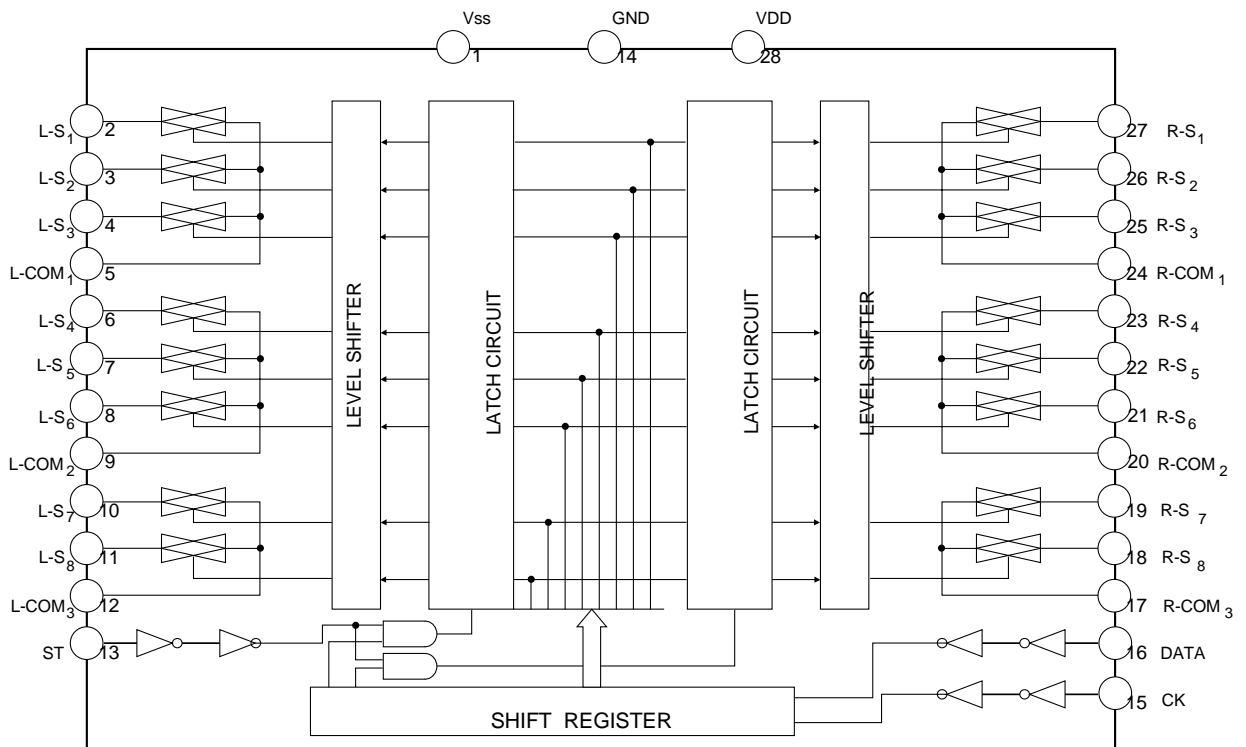

**TOSHIBA****TC9214,15AP/AF**

TOSHIBA CMOS DIGITAL INTEGRATED CIRCUIT SILICON MONOLITHIC

**TC9214AP, TC9214AF, TC9215AP, TC9215AF****HIGH VOLTAGE ANALOG SWITCH**

TC9214AP/AF, TC9215AP/AF are Analog Switch for high voltage audio application.

**FEATURES**

- Analog Switch Circuit Formation  
TC9214AP, TC9214AF : 5 circuits  
TC9215AP, TC9215AF : 6 circuits
- Dual Power Supply of (+) and (-) can be used.
- Including Level Shift Circuit, this IC can be operated by (+) power supply only under dual power supply operating.
- Setting Low Input-threshold-voltage in control signal input terminal. 5V CPU application can control this IC directly.
- Package : DIP-16 PIN  
SOP-16 PIN

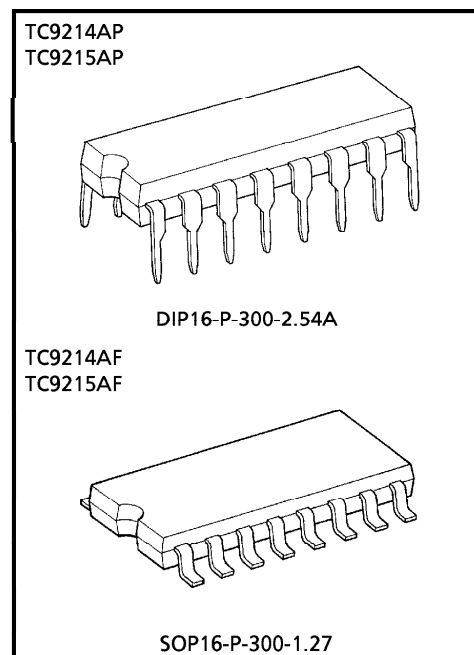

Weight  
DIP16-P-300-2.54A : 1.0g (Typ.)  
SOP16-P-300-1.27 : 0.16g (Typ.)

**PIN CONNECTION (TOP VIEW)**

TC9214AP, TC9214AF

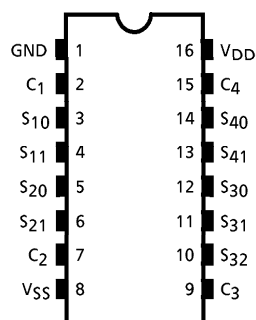

TC9215AP, TC9215AF

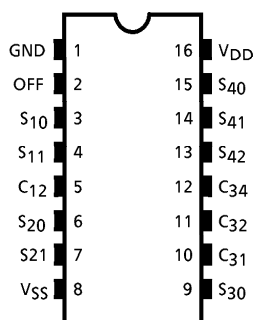

980508EBA2

**TOSHIBA**

**TC9214,15AP/AF**

**BLOCK DIAGRAM**

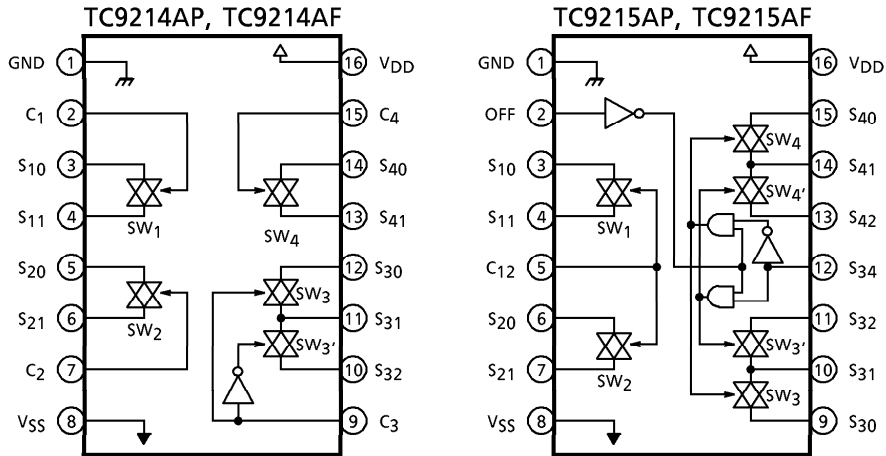

**PIN FUNCTION**

1. TC9214AP, TC9214AF

PIN No.	SYMBOL	PIN NAME	FUNCTION	NOTE																		
1	GND	Ground Terminal	Dual power supplying : + B →V <sub>DD</sub> 0V →GND - B →V <sub>SS</sub>	—																		
8	V <sub>SS</sub>	(-) Power Supply Terminal																				
16	V <sub>DD</sub>	(+) Power Supply Terminal																				
2	C <sub>1</sub>	Switch (1) Control Terminal	SWITCH CONNECTION   TRUTH TABLE <table border="1" style="margin-left: auto; margin-right: auto;"> <tr> <td>C<sub>1</sub>, C<sub>2</sub>, C<sub>4</sub></td> <td colspan="2">SW<sub>1</sub>, SW<sub>2</sub>, SW<sub>3</sub></td> </tr> <tr> <td>H</td> <td colspan="2">ON</td> </tr> <tr> <td>L</td> <td colspan="2">OFF</td> </tr> </table>  <table border="1" style="margin-left: auto; margin-right: auto;"> <tr> <td>C<sub>3</sub></td> <td>S<sub>30</sub>-S<sub>31</sub></td> <td>S<sub>31</sub>-S<sub>32</sub></td> </tr> <tr> <td>H</td> <td>ON</td> <td>OFF</td> </tr> <tr> <td>L</td> <td>OFF</td> <td>ON</td> </tr> </table>	C <sub>1</sub> , C <sub>2</sub> , C <sub>4</sub>	SW <sub>1</sub> , SW <sub>2</sub> , SW <sub>3</sub>		H	ON		L	OFF		C <sub>3</sub>	S <sub>30</sub> -S <sub>31</sub>	S <sub>31</sub> -S <sub>32</sub>	H	ON	OFF	L	OFF	ON	—
C <sub>1</sub> , C <sub>2</sub> , C <sub>4</sub>	SW <sub>1</sub> , SW <sub>2</sub> , SW <sub>3</sub>																					
H	ON																					
L	OFF																					
C <sub>3</sub>	S <sub>30</sub> -S <sub>31</sub>	S <sub>31</sub> -S <sub>32</sub>																				
H	ON	OFF																				
L	OFF	ON																				
3	S <sub>10</sub>	Switch (1) Input/Output Terminal																				
4	S <sub>11</sub>																					
5	S <sub>20</sub>	Switch (2) Input/Output Terminal																				
6	S <sub>21</sub>																					
7	C <sub>2</sub>	Switch (2) Control Terminal																				
9	C <sub>3</sub>	Switch (3) Control Terminal																				
10	S <sub>32</sub>	Switch (3) Input/Output Terminal																				
11	S <sub>31</sub>																					
12	S <sub>30</sub>																					
13	S <sub>41</sub>	Switch (4) Input/Output Terminal																				
14	S <sub>40</sub>																					
15	C <sub>4</sub>		Switch (4) Control Terminal																			

**TOSHIBA****TC9214,15AP/AF**

## 2. TC9215AP, TC9215AF

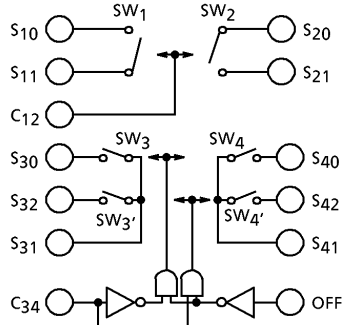
PIN No.	SYMBOL	PIN NAME	FUNCTION	NOTE																					
1	GND	Ground Terminal	Dual power supplying : + B →V <sub>DD</sub> 0V →GND - B →V <sub>SS</sub>	—																					
8	V <sub>SS</sub>	(-) Power Supply Terminal																							
16	V <sub>DD</sub>	(+) Power Supply Terminal			Single power supplying: + B →V <sub>DD</sub> 0V →GND, V <sub>SS</sub>																				
2	OFF	Switch (3), (4) OFF Input Terminal	<b>SWITCH CONNECTION</b>  <b>TRUTH TABLE</b> <table border="1" data-bbox="726 1052 1189 1182"> <thead> <tr> <th>C<sub>12</sub></th> <th>SW<sub>1</sub>, SW<sub>2</sub></th> </tr> </thead> <tbody> <tr> <td>H</td> <td>ON</td> </tr> <tr> <td>L</td> <td>OFF</td> </tr> </tbody> </table> <table border="1" data-bbox="726 1220 1284 1377"> <thead> <tr> <th>OFF</th> <th>C<sub>34</sub></th> <th>S<sub>30</sub>-S<sub>31</sub> S<sub>40</sub>-S<sub>41</sub></th> <th>S<sub>31</sub>-S<sub>32</sub> S<sub>41</sub>-S<sub>42</sub></th> </tr> </thead> <tbody> <tr> <td rowspan="2">L</td> <td>L</td> <td>ON</td> <td>OFF</td> </tr> <tr> <td>H</td> <td>OFF</td> <td>ON</td> </tr> <tr> <td>H</td> <td>※</td> <td>OFF</td> <td>OFF</td> </tr> </tbody> </table> (※ H or L)	C <sub>12</sub>	SW <sub>1</sub> , SW <sub>2</sub>	H	ON	L	OFF	OFF	C <sub>34</sub>	S <sub>30</sub> -S <sub>31</sub> S <sub>40</sub> -S <sub>41</sub>	S <sub>31</sub> -S <sub>32</sub> S <sub>41</sub> -S <sub>42</sub>	L	L	ON	OFF	H	OFF	ON	H	※	OFF	OFF	—
C <sub>12</sub>	SW <sub>1</sub> , SW <sub>2</sub>																								
H	ON																								
L	OFF																								
OFF	C <sub>34</sub>	S <sub>30</sub> -S <sub>31</sub> S <sub>40</sub> -S <sub>41</sub>		S <sub>31</sub> -S <sub>32</sub> S <sub>41</sub> -S <sub>42</sub>																					
L	L	ON		OFF																					
	H	OFF		ON																					
H	※	OFF		OFF																					
3	S <sub>10</sub>	Switch (1) Input/ Output Terminal																							
4	S <sub>11</sub>																								
5	C <sub>12</sub>	Switch (1), (2) Control Terminal																							
6	S <sub>20</sub>	Switch (2) Input/ Output Terminal																							
7	S <sub>21</sub>																								
9	S <sub>30</sub>	Switch (3) Input/ Output Terminal																							
10	S <sub>31</sub>																								
11	S <sub>32</sub>																								
12	C <sub>34</sub>	Switch (3), (4) Control Terminal																							
13	S <sub>42</sub>	Switch (4) Input/ Output Terminal																							
14	S <sub>41</sub>																								
15	S <sub>40</sub>																								

**BLOCK DIAGRAM (TC9459F)**

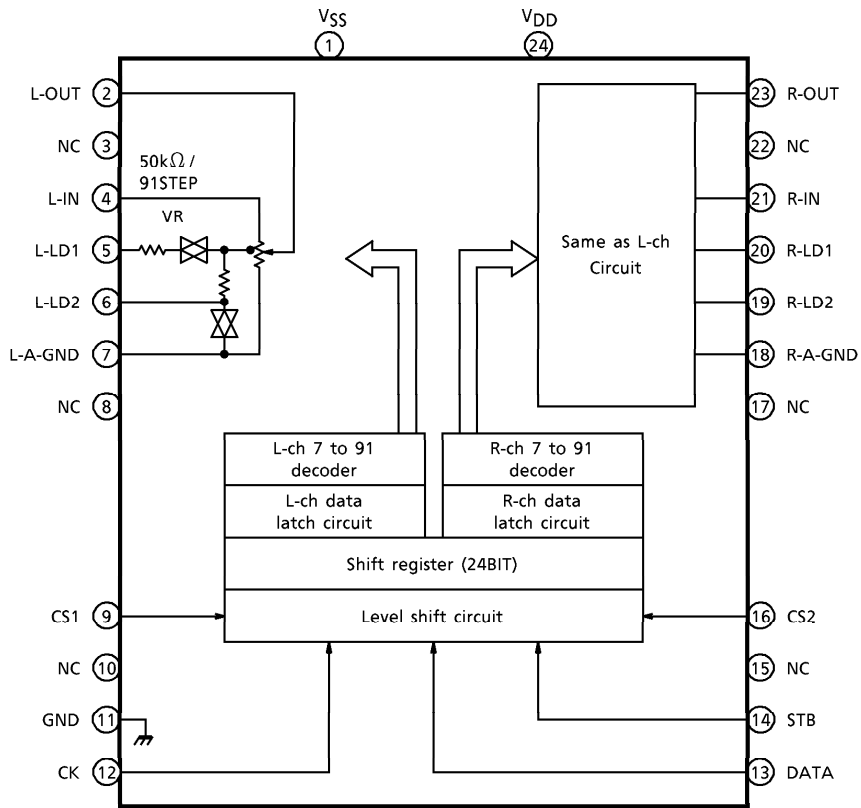

**TOSHIBA****TC9459N/F****PIN DESCRIPTION**

Numeral in ( ) means the pin No. of TC9459F.

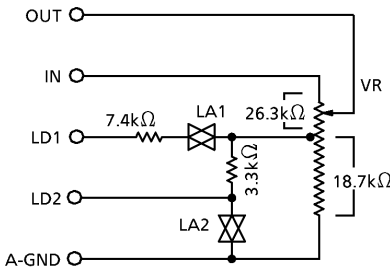
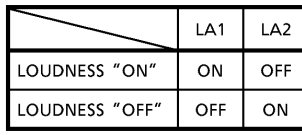
PIN No.	SYMBOL	PIN NAME	FUNCTION	REMARK	
1 (1)	V <sub>SS</sub>	Negative power supply pin	When using dual power supplies $V_{DD} = 6.0 \sim 17V$ $GND = 0V$ $V_{SS} = -6.0 \sim -17V$ When using a single power supply $V_{DD} = 6.0 \sim 18V$ $GND = V_{SS} = 0V$	—	
28 (24)	V <sub>DD</sub>	Positive power supply pin			
13 (11)	GND	Digital GND pin			
3 (2)	L-OUT	Volume output pin	• Volume circuit 	—	
26 (23)	R-OUT				
5 (4)	L-IN	Volume input pin			
24 (21)	R-IN				
6 (5)	L-LD1	Loudness tap output pin			
23 (20)	R-LD1				
7 (6)	L-LD2				
22 (19)	R-LD2				
8 (7)	L-A-GND	Analog GND pin			
21 (18)	R-A-GND				
10 (9)	CS1	Chip select input pin	Up to 4 chips on the same bus can be used by switching over chip select code.	—	
19 (16)	CS2				
14 (12)	CK	Clock input pin	Data transfer clock input	Low threshold value input pin	
15 (13)	DATA	Data input pin	Volume setup serial data input		
16 (14)	STB	Strobe input pin	Data write strobe input		
2 (3)	NC	No connection	—	—	
27 (22)					
4					
25					
9 (8)					
20 (17)					
11					
18					
12 (10)					
17 (15)					

**TOSHIBA**

TC9482BNG/BFG

TOSHIBA CMOS DIGITAL INTEGRATED CIRCUIT SILICON MONOLITHIC

# TC948BNG, TC9482BFG

2

## SYSTEM ELECTRONIC VOLUME CONTROL



The TC9482BNG and TC9482BFG are six-channel electronic volume control ICs developed for Hi-Fi audio equipment. Since all six channels can be individually controlled, the devices are optimum for audio equipment with multiple outputs.

### FEATURES

- Sound volume can be controlled in 97 steps from 0 to -95dB or up to an infinite level in 1dB increments.
- Incorporating six channels of volume control circuits, the device allows independent volume control.
- Can operate with a single or dual power supplies.
- Can control up to 4 chips on the same bus by using chip select input.
- Built-in interface for 3-V microcomputers.
- Thanks to its polysilicon resistor, the device allows you to configure a low-distortion, high-performance volume control system.
- Two packages supported: 28-pin shrink DIP and 28-pin flat package.

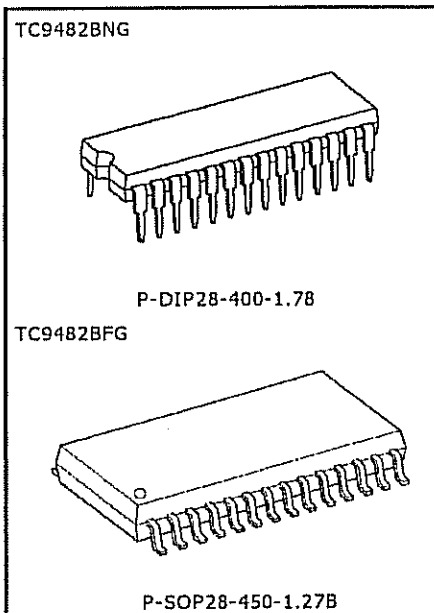

Weight  
 P-SDIP28-400-1.78 : 2.2 g (Typ.)  
 P-SOP28-450-1.27B : 0.8 g (Typ.)



**TOSHIBA**

**TC9482BNG/BFG**

**PIN CONNECTIONS**

V <sub>SS</sub>	1	28	V <sub>DD</sub>
NC	2	27	TEST
L-OUTA	3	26	R-OUTA
L-INA	4	25	R-INA
L-A-GNDA	5	24	R-A-GNDA
L-OUTB	6	23	R-OUTB
L-INB	7	22	R-INB
L-A-GNDB	8	21	R-A-GNDB
L-OUTC	9	20	R-OUTC
L-INC	10	19	R-INC
L-A-GNDC	11	18	R-A-GNDC
CS1	12	17	CS2
GND	13	16	STB
CK	14	15	DATA

**BLOCK DIAGRAM**

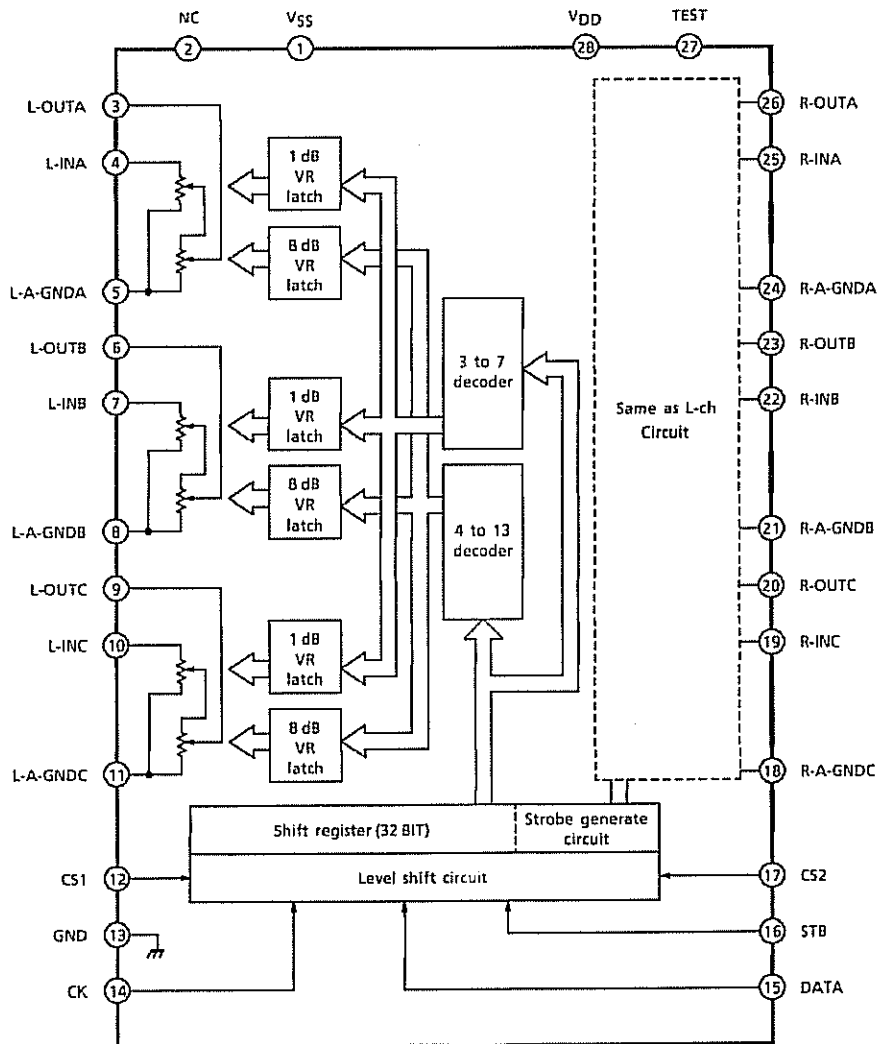

**TOSHIBA**

TC9482BNG/BFG

## PIN DESCRIPTION

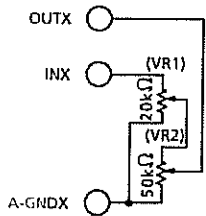
PIN No.	SYMBOL	PIN NAME	FUNCTION	REMARK
1	V <sub>SS</sub>	Negative power supply pin	• Power Supply Pins	—
28	V <sub>DD</sub>	Positive power supply pin		
3	L-OUTA	Volume output pin	• Volume circuit  	—
26	R-OUTA			
6	L-OUTB			
22	R-OUTB			
9	L-OUTC			
19	R-OUTC			
4	L-INA	Volume input pin		—
25	R-INA			
7	L-INB			
22	R-INB			
10	L-INC			
19	R-INC	Analog GND pin		—
5	L-A-GNDA			
24	R-A-GNDA			
8	L-A-GNDB			
21	R-A-GNDB			
11	L-A-GNDC	Chip select input pin	Up to 4 chips on the same bus can be used by switching over chip select code.	—
18	R-A-GNDC			
12	CS1	Chip select input pin	Up to 4 chips on the same bus can be used by switching over chip select code.	—
17	CS2			
14	CK	Clock input pin	Inputs clock for serial data transfer.	Low threshold value input pin
15	DATA	Data input pin	Inputs control data for setting volume.	
16	STB	Strobe input pin	Inputs strobe for writing data.	
13	GND	Digital GND pin	Digital ground pin	—
27	TEST	Test Pin	Normally connect to V <sub>DD</sub> pin.	—
2	NC	No connection	—	—



# M29W800DT M29W800DB

8 Mbit (1Mb x8 or 512Kb x16, Boot Block)  
3V Supply Flash Memory

## FEATURES SUMMARY

- SUPPLY VOLTAGE
  - $V_{CC} = 2.7V$  to  $3.6V$  for Program, Erase and Read
- ACCESS TIME: 70, 90ns
- PROGRAMMING TIME
  - $10\mu s$  per Byte/Word typical
- 19 MEMORY BLOCKS
  - 1 Boot Block (Top or Bottom Location)
  - 2 Parameter and 16 Main Blocks
- PROGRAM/ERASE CONTROLLER
  - Embedded Byte/Word Program algorithms
- ERASE SUSPEND and RESUME MODES
  - Read and Program another Block during Erase Suspend
- UNLOCK BYPASS PROGRAM COMMAND
  - Faster Production/Batch Programming
- TEMPORARY BLOCK UNPROTECTION MODE
- COMMON FLASH INTERFACE
  - 64 bit Security Code
- LOW POWER CONSUMPTION
  - Standby and Automatic Standby
- 100,000 PROGRAM/ERASE CYCLES per BLOCK
- ELECTRONIC SIGNATURE
  - Manufacturer Code: 0020h
  - Top Device Code M29W800DT: 22D7h
  - Bottom Device Code M29W800DB: 225Bh

Figure 1. Packages

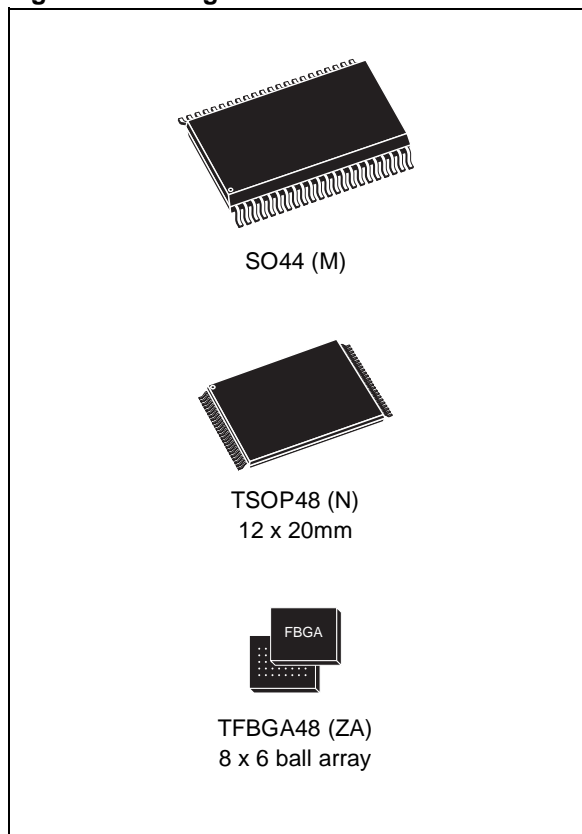

**M29W800DT, M29W800DB**

**Figure 3. SO Connections**

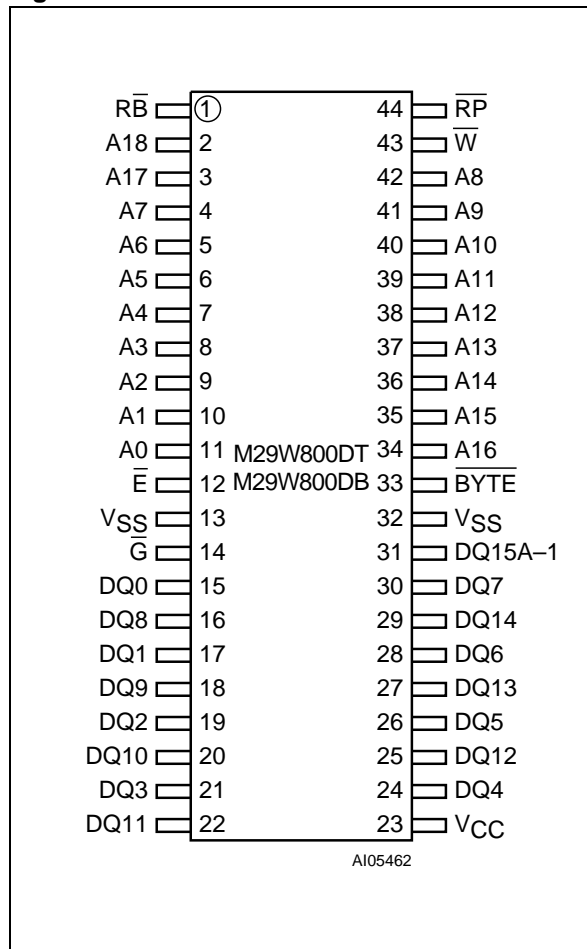

**Figure 4. TSOP Connections**

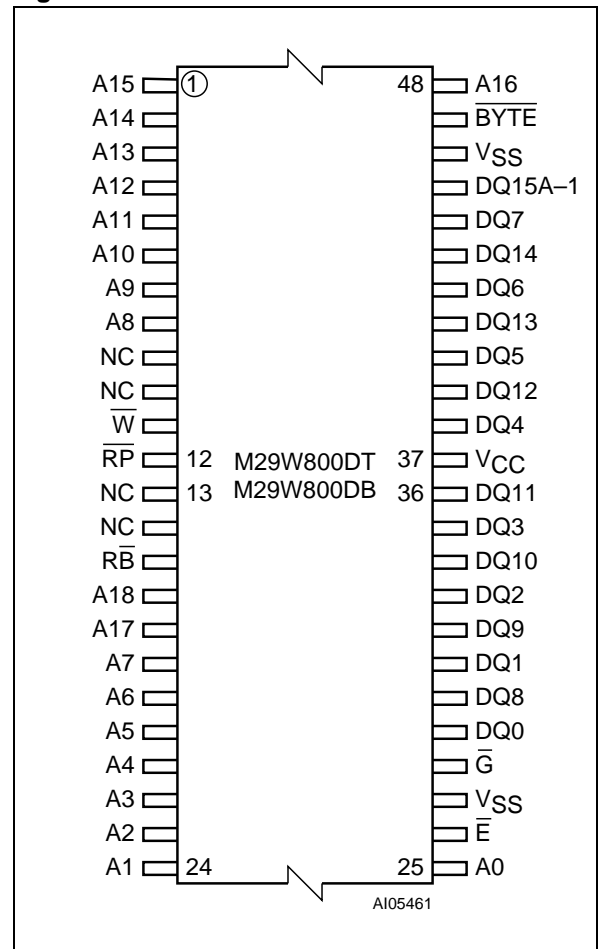

## NJM2586AM [WIDE BAND 3-INPUT 1-OUTPUT 3-CIRCUIT VIDEO AMPLIFIER]

[STRUCTURE] Bipolar  
 [CATEGORIES] TV-Video  
 [PACKAGE OUTLINE] DMP-24  
 [SOLDERING METHOD] For this device, soldering method is recommended Reflow.  
 [NOTE] -

■ **ABSOLUTE MAXIMUM RATINGS**  $T_a=25^\circ\text{C}$

BAE-38461-000-01

Supply Voltage .....	$\pm 6.0$ [V]	Operating Temperature Range .....	-40 to +85 [°C]
Power Dissipation .....	500 [mW]	Storage Temperature Range .....	-40 to +125 [°C]

■ **BLOCK DIAGRAM**

BDE-33546-000-00

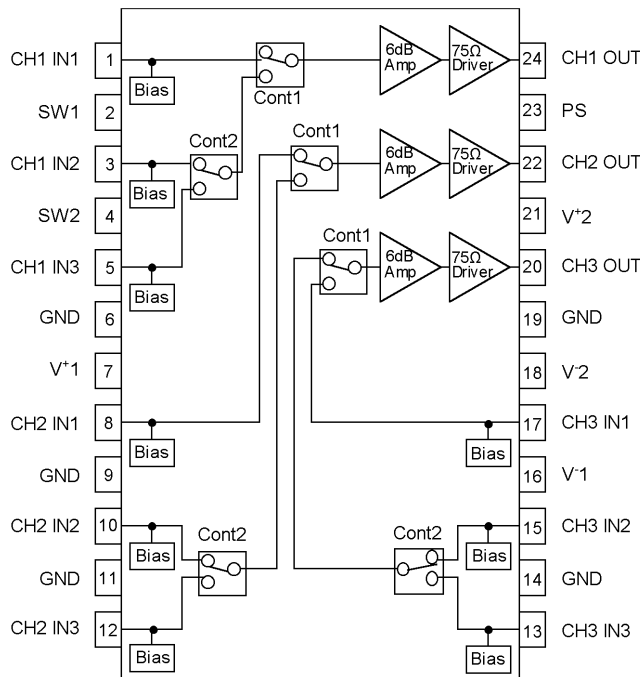





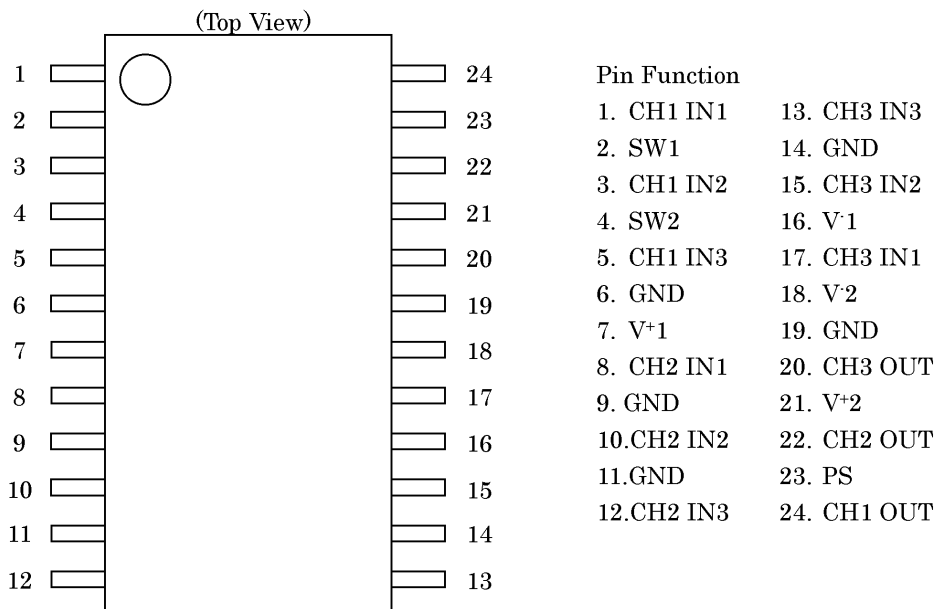

■ **PIN CONFIGURATION**

BEE-33546-000-01

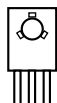

**TRANSISTOR, REGULATOR IC BLOCK DIAGRAM**

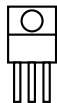
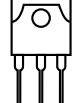
<p><b>TO-92M</b></p>  <p>1. Emitter 2. Collector 3. Base</p> <p><b>123</b></p> <p>KTC2874B    KSC2785Y KRA107M    KRC107M KRA104MT</p>	<p><b>TO-92</b></p>  <p>1. Emitter 2. Collector 3. Base</p> <p><b>123</b></p> <p>KTD1302T    KTA1268GR KTC3200GR    KTC3198Y KTA1271Y    KSA1175YT</p>	<p><b>TO-220</b></p>  <p>1. GND 2. INPUT 3. OUTPUT</p> <p><b>123</b></p> <p>MCNJM7905    MC7915C</p>	<p><b>TO-92L</b></p>  <p>1. Emitter 2. Collector 3. Base</p> <p><b>123</b></p> <p>KTA1024Y    KSC2316Y</p>
<p><b>TO-126</b></p>  <p>1. Emitter 2. Collector 3. Base</p> <p><b>123</b></p> <p>2SA1360O    2SC3423O KTD600KG</p>	<p><b>TO-92</b></p>  <p>1. Emitter 2. Base 3. Collector</p> <p><b>123</b></p> <p>KSA733CYT</p>	<p><b>TO-220</b></p>  <p>1. INPUT 2. GND 3. OUTPUT</p> <p><b>123</b></p> <p>MC7815C    MC7805C</p>	<p><b>TO-3P</b></p>  <p>1. Base 2. Collector 3. Emitter</p> <p><b>1 2 3</b></p> <p>2SB1560 2SD2390</p>

**NJM2391DL1-25    NJM2391DL1-33**  
**LOW DROPOUT VOLTAGE REGULATOR**

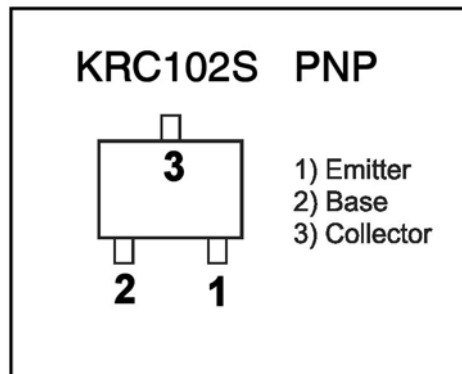
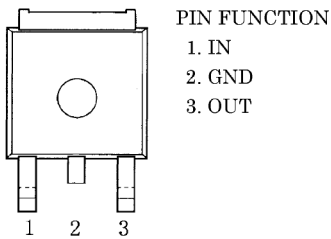

AVR140

harman/kardon

CUP11834Z

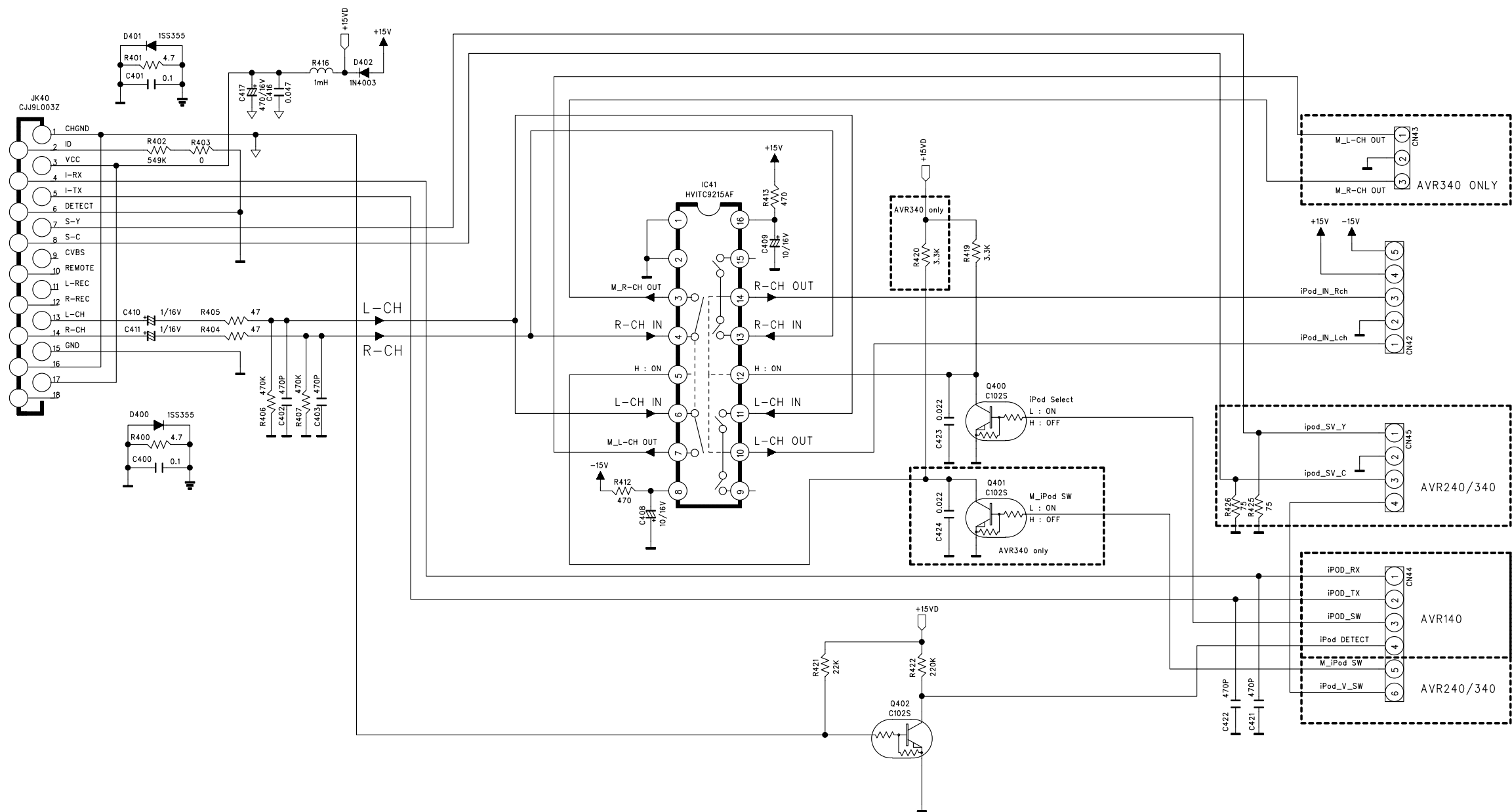

REVISION	2	4	6	
1	3	5	7	
SCHEMATIC DIAGRAM				SHEET
MODEL	AVR140/240/340			2 4
DESIGN	CHECK	APPROVE	DRAWING NO	
L.J.Y	L.B.C	L.H.W	1834SCMZ	
05.06.28	05.07.29	05.07.29	(DMP)	1 1

AVR140

< BIAS T.R PCB >

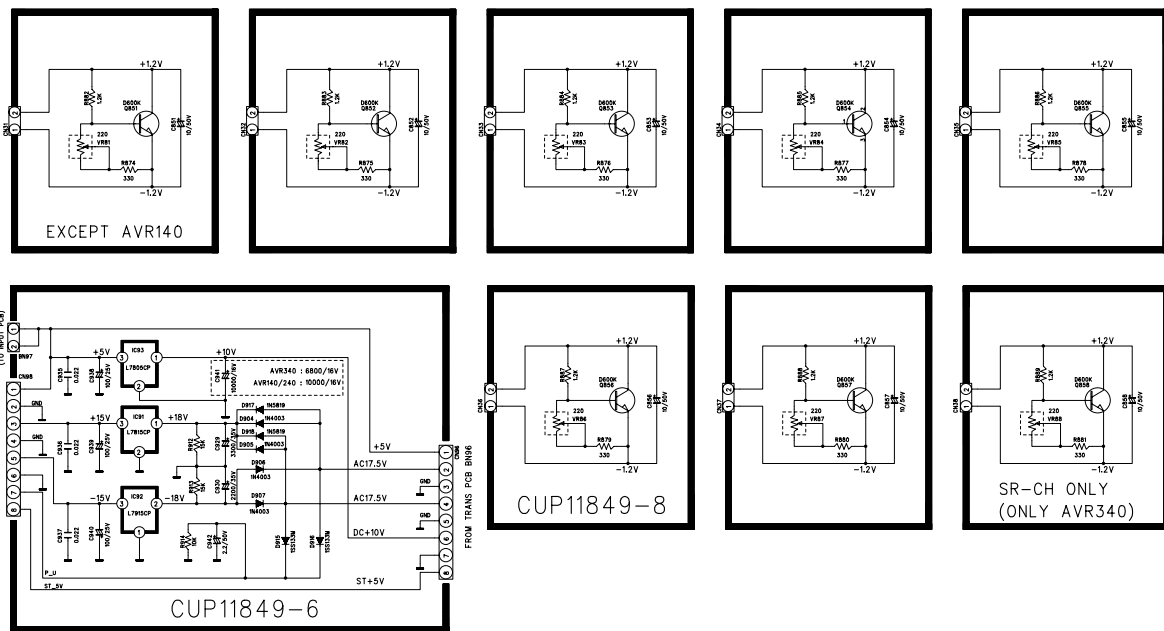

< POWER TRANS & OUTLET PCB >

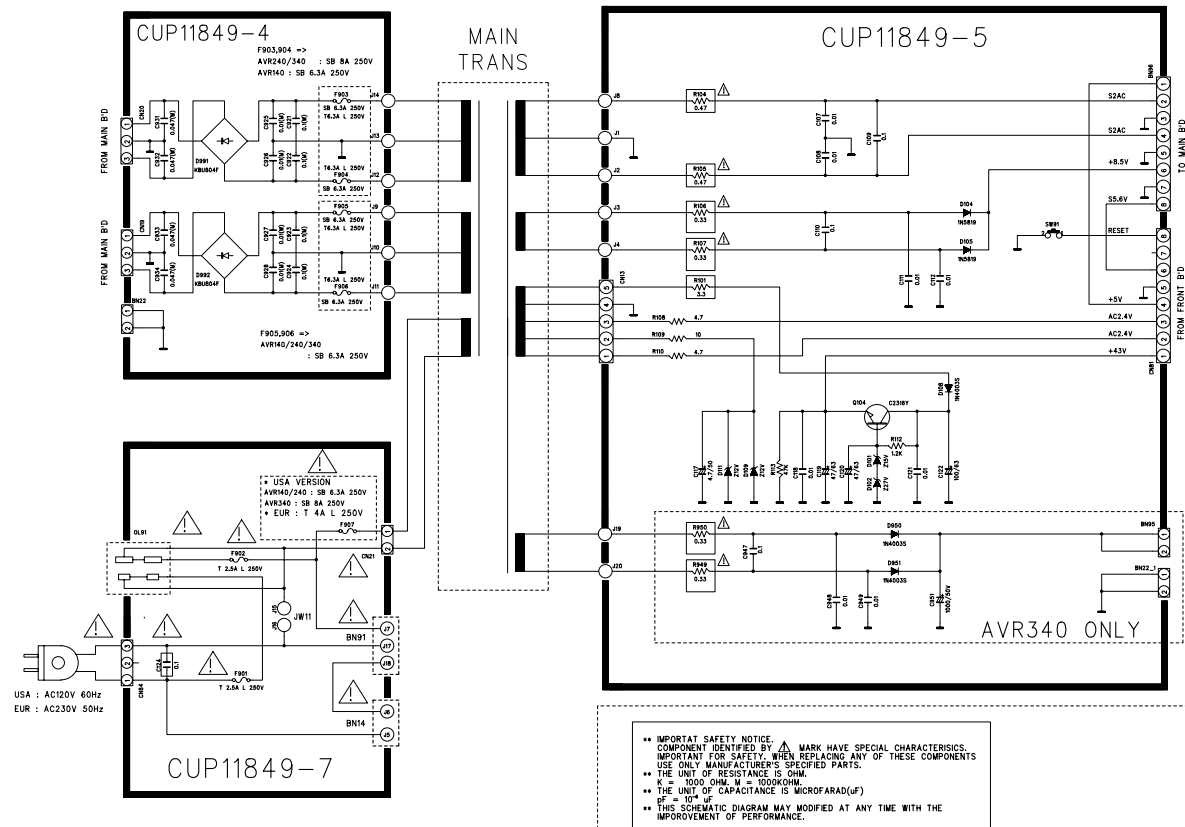

IMPORTANT SAFETY NOTICE  
 COMPONENT IDENTIFIED BY MARK HAVE SPECIAL CHARACTERISTICS.  
 IMPORTANT FOR SAFETY. WHEN REPLACING ANY OF THESE COMPONENTS  
 USE ONLY MANUFACTURER'S SPECIFIED PARTS.  
 \* THE UNIT OF RESISTANCE IS OHM.  
 \* K = 1000 OHM, M = 10000OHM.  
 \* THE UNIT OF CAPACITANCE IS MICROFARAD(UF)  
 \* UF = 10<sup>-6</sup> F  
 \* THIS SCHEMATIC DIAGRAM MAY MODIFIED AT ANY TIME WITH THE  
 IMPROVEMENT OF PERFORMANCE.

REVISION	2	4	6
1	3	5	7
SCHEMATIC DIAGRAM			SHEET
MODEL	AVR140, AVR140/230		7/8
DESIGN	CHECK	APPROVE	DRAWING NO
LEE C B	Y.W.Y	L.H.W	1816SCMZ
05.02.03			(BIAS&MIC&POWER TRANS) 2/2



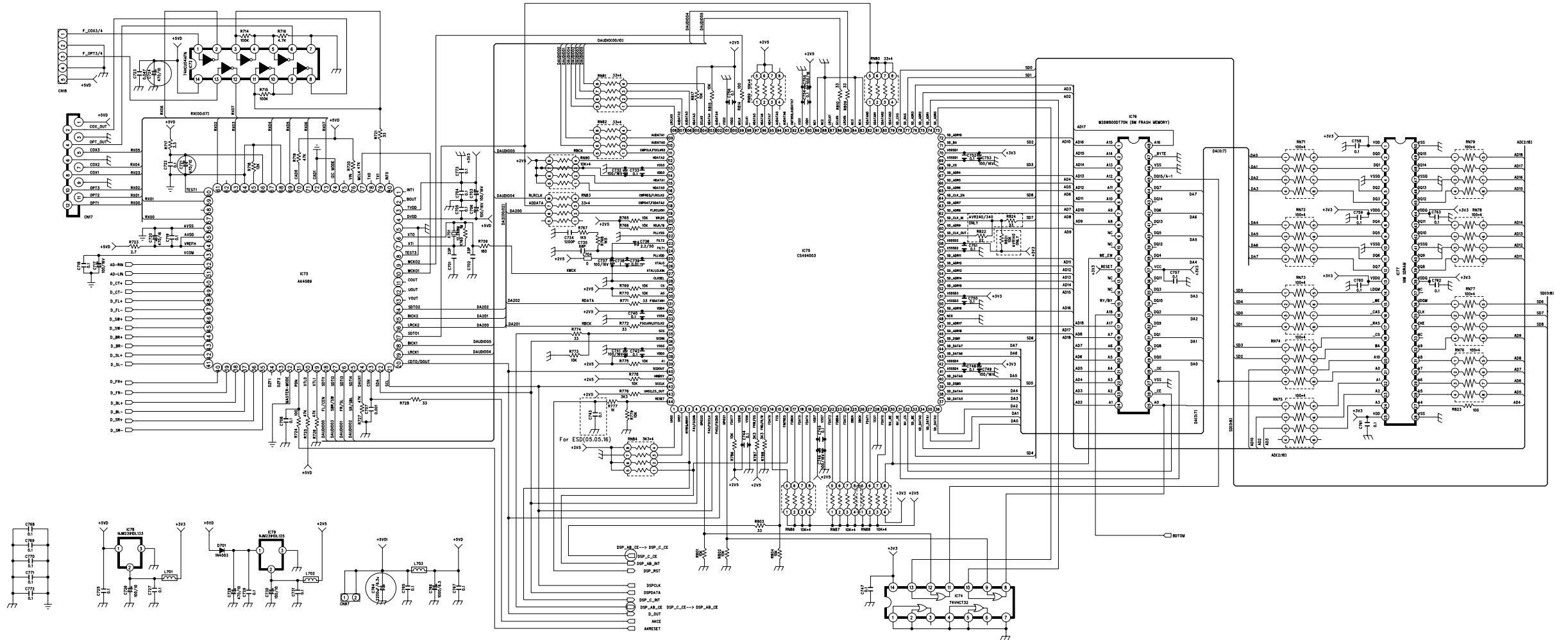

CUP11814-1

M/P



REVISION	2	4	6
1	3	5	7
SCHMATIC DIAGRAM			
MODEL	AVR140/240		
DESIGN	CHECK	APPROVE	DRAWING NO
Y.W.Y	Y.W.Y	L.H.W	1814SCMZ

# AVR140

harman/kardon

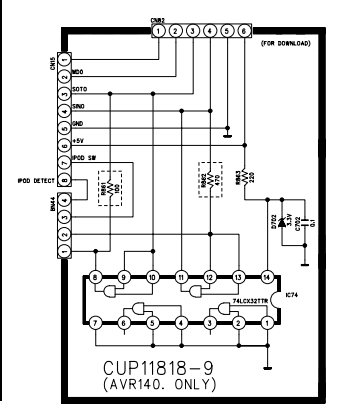
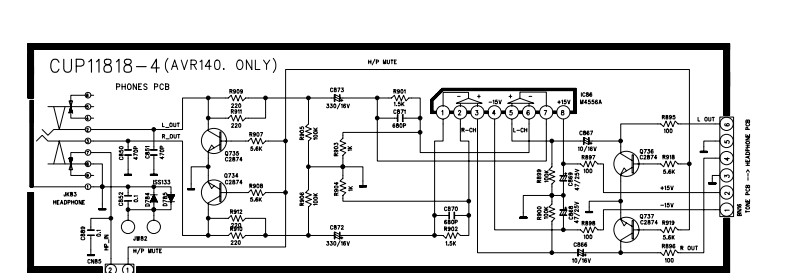
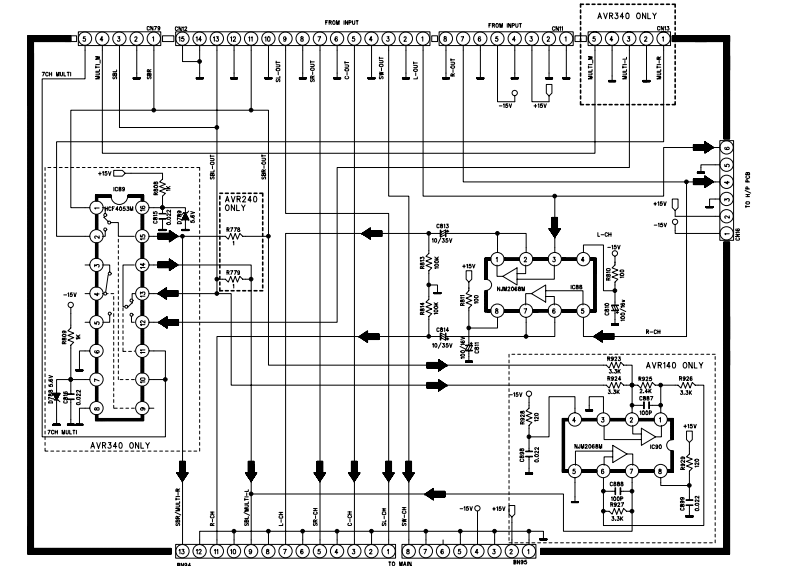
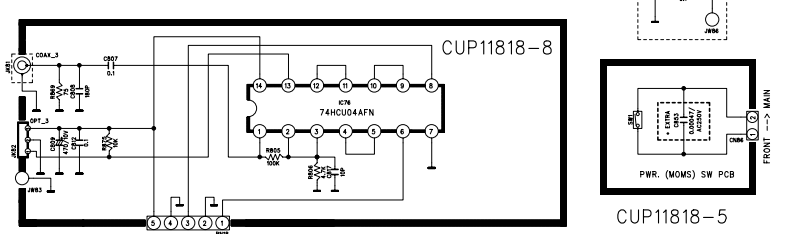
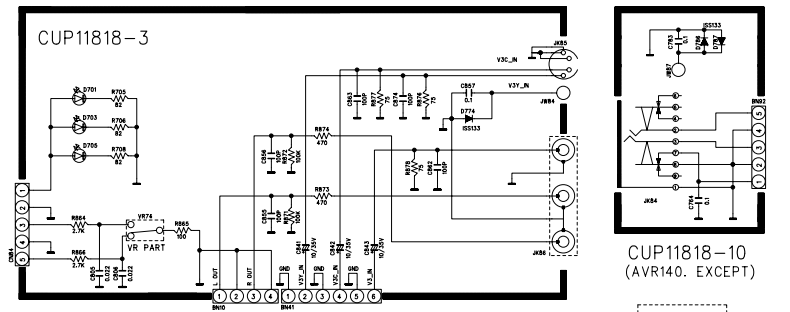
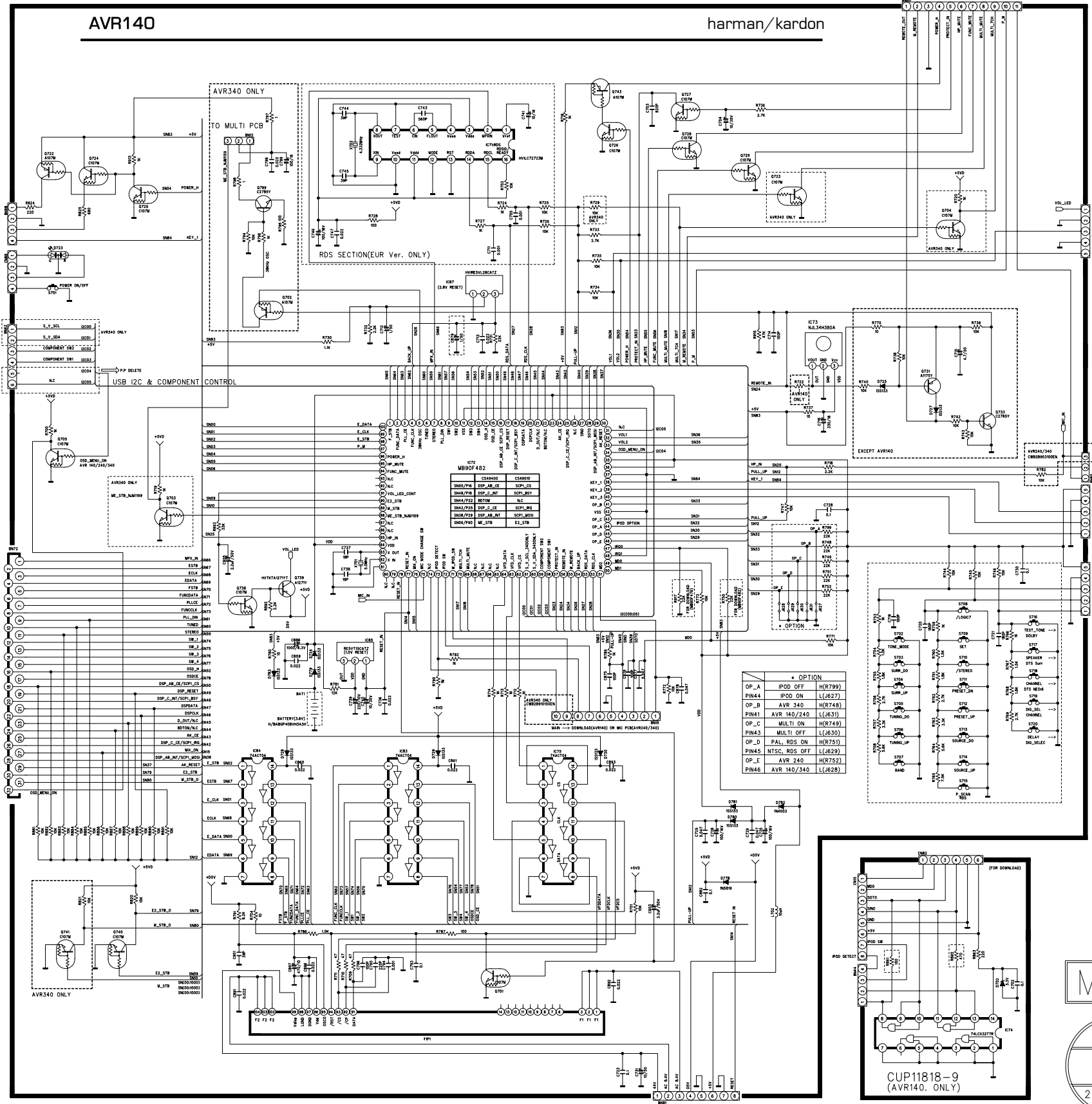

M/P

JSUE  
2005.06.0

REVISION	2	4	6
1	3	5	7
SCHEMATIC DIAGRAM			
MODEL	AVR140/240/340		
DESIGN	CHECK	APPROVE	DRAWING NO
C.H.C	Y.W.Y	LEE H W	1818SCMZ
05.06.23			(FRONT)

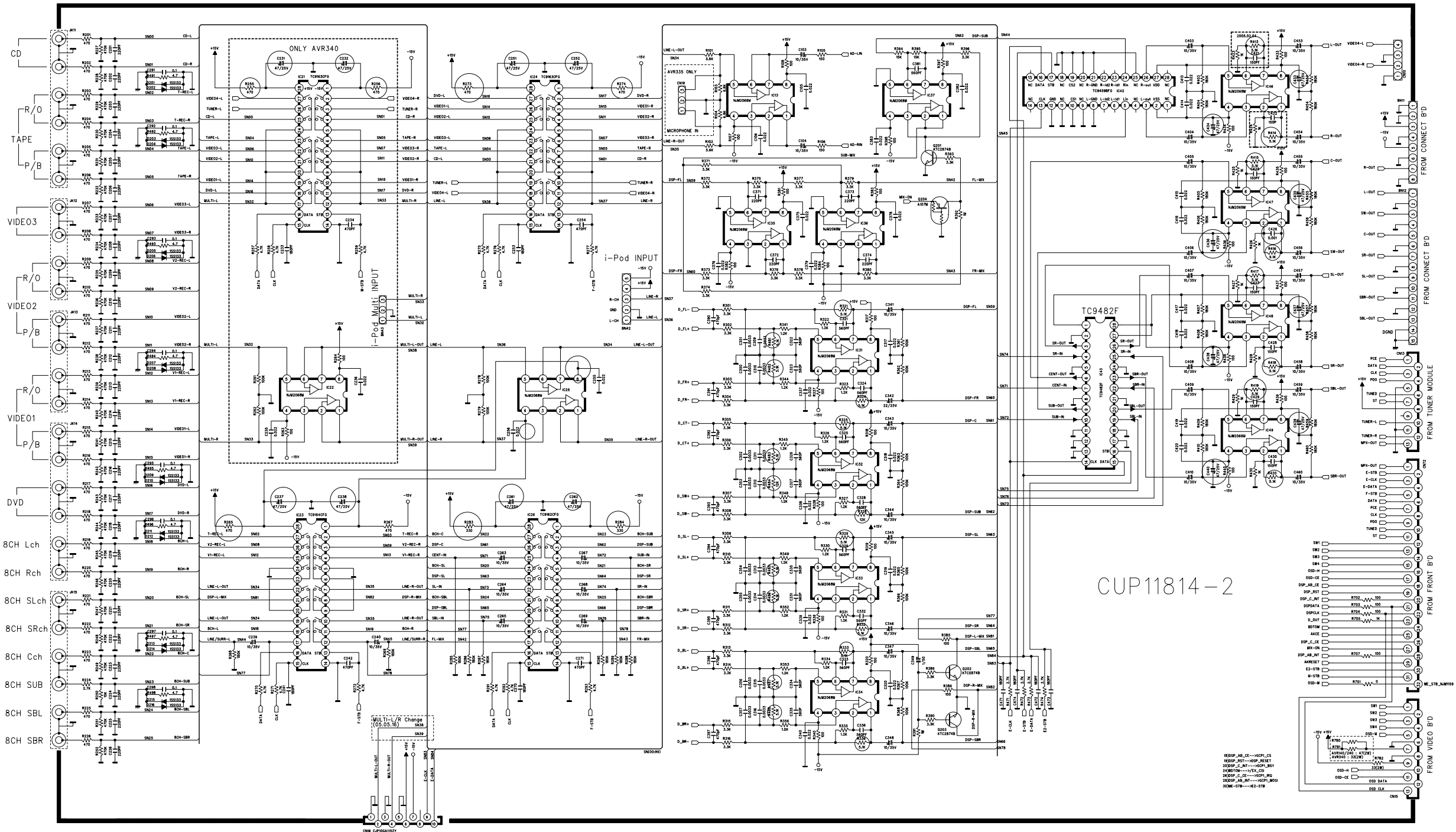

CUP11814-2

•• IMPORTANT SAFETY NOTICES.  
 COMPONENTS IDENTIFIED BY  $\Delta$  MARK HAVE SPECIAL CHARACTERISTICS.  
 IMPORTANT FOR SAFETY. WHEN REPLACING ANY OF THESE COMPONENTS  
 USE ONLY MANUFACTURER'S SPECIFIED PARTS.  
 •• THE UNIT OF RESISTANCE IS OHM.  
 K=1000 OHM , M=1000 KOHM  
 •• THE UNIT OF CAPACITANCE IS MICROFARAD. ( $\mu$ F)  
 $\mu$ F=10<sup>-6</sup> uF  
 •• THIS SCHEMATIC DIAGRAM MAY BE MODIFIED AT ANY TIME WITH THE  
 IMPROVEMENT OF PERFORMANCE.

M/P



REVISION	2	4	6
1	3	5	7
SCHEMATIC DIAGRAM			SHEET
MODEL	AVR140/240/340		3/6
DESIGN	CHECK	APPROVE	DRAWING NO
K.M.S	Y.W.Y	L.H.W	1814SCEZ
04.02.20			(INPUT) 1/2

# CUP11835

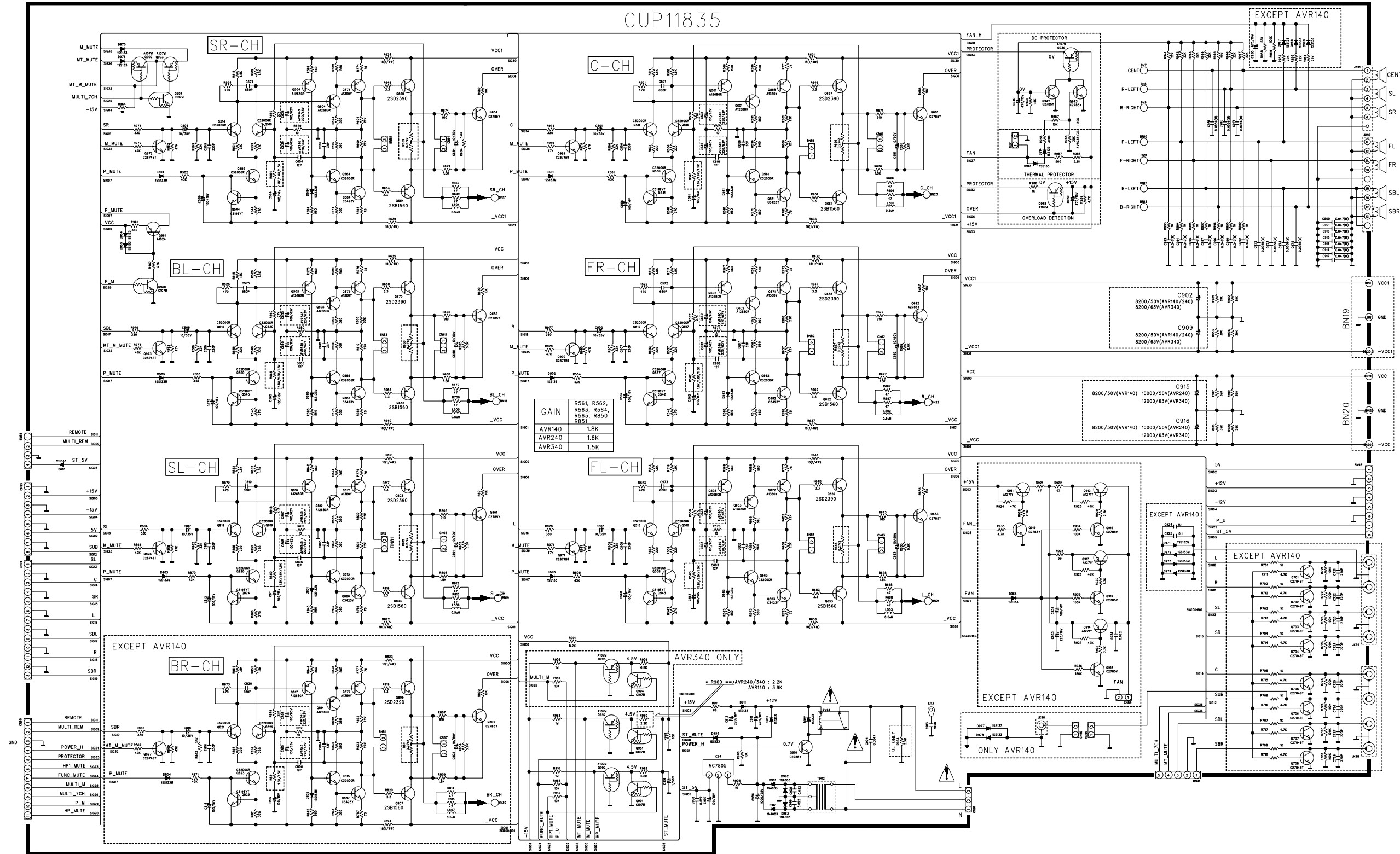

AVR140

harman/kardon

M/P

SUE  
2002.02.27

REVISION	1	2	3	SHEET
SCHEMATIC DIAGRAM				2
MODEL	AVR140, AVR240, AVR340			6
DESIGN	CHECK	APPROVE	DRAWING NO	
L.C.B	Y.W.Y	L.H.W	1835SCMZ	
04.02.24				(MAIN)

- IMPORTANT SAFETY NOTICE.
- IMPORTANT FOR SAFETY WHEN REPLACING ANY OF THESE COMPONENTS
- USE ONLY MANUFACTURER'S SPECIFIED PARTS.
- THE UNIT OF RESISTANCE IS OHM.
- K=1000 OHM, M=1000 K OHM.
- THE UNIT OF CAPACITANCE IS MICROFARAD (µF)
- pF = 10<sup>-12</sup> F
- THIS SCHEMATIC DIAGRAM MAY MODIFIED AT ANY TIME WHILE THE IMPROVEMENT OF PERFORMANCE.

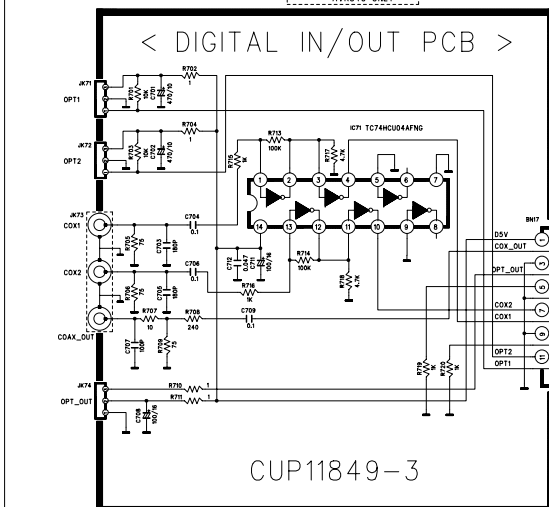
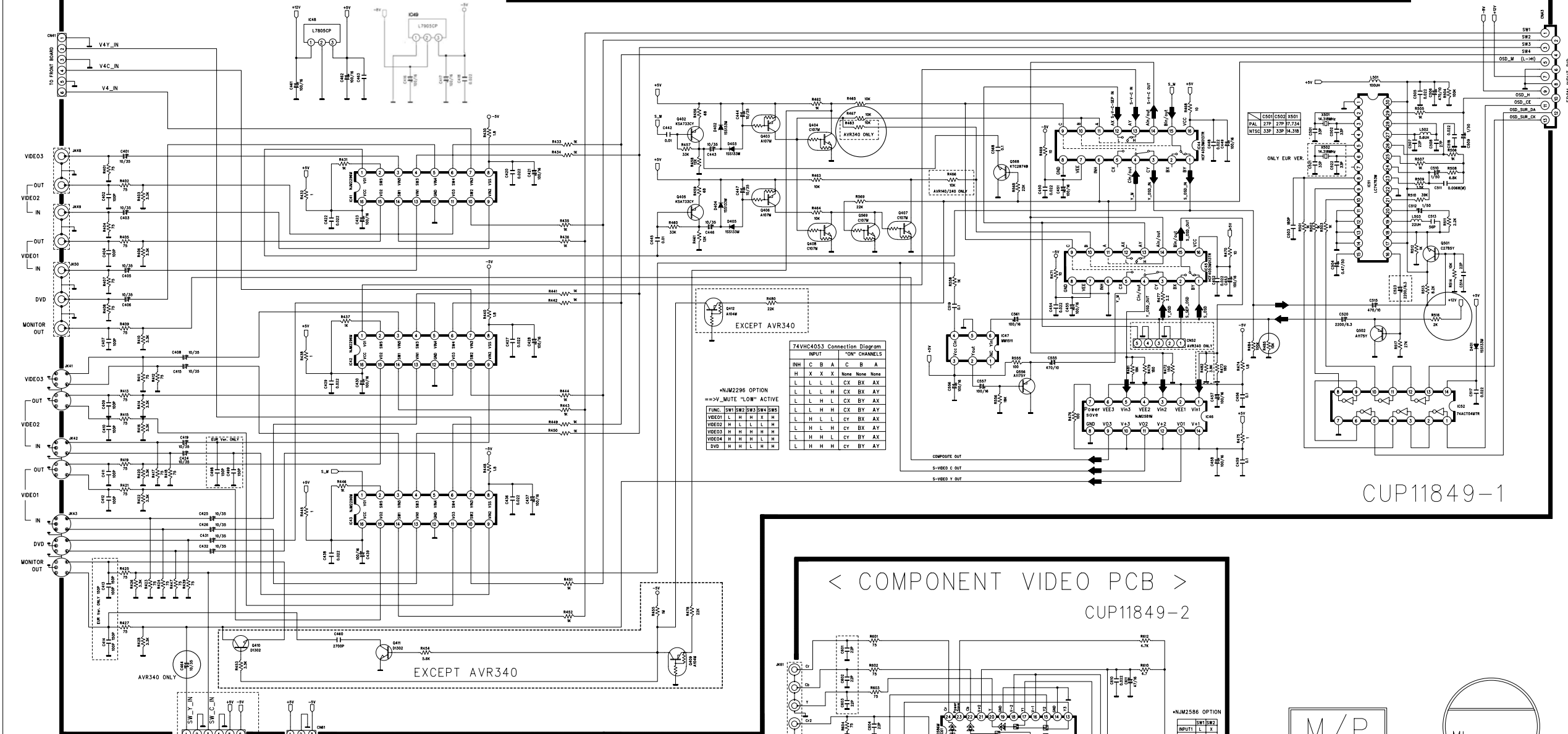

CUP11849-3

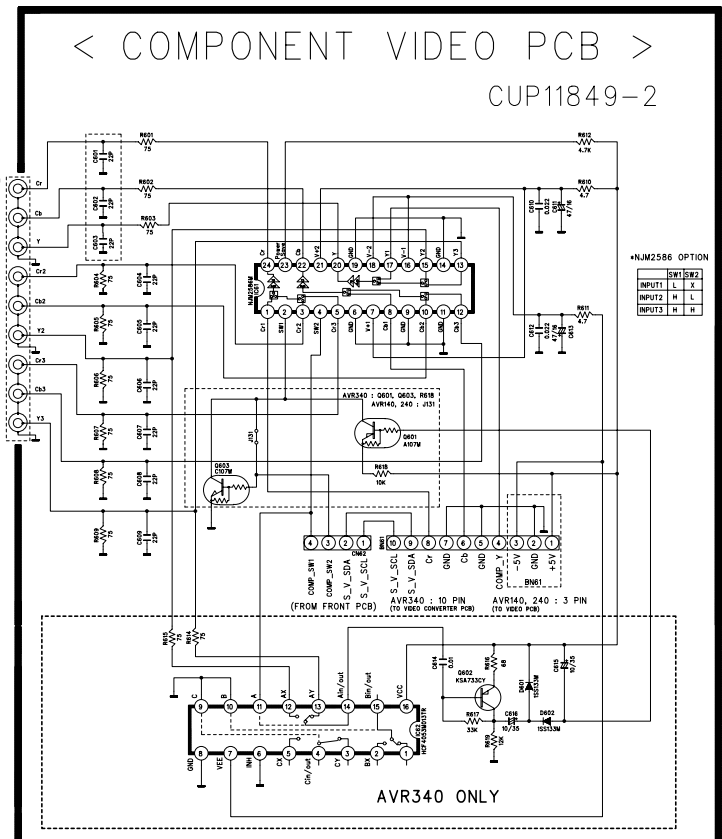

CUP11849-2

M/P

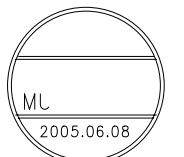

REVISION	2	4	6
	3	5	7
SCHEMATIC DIAGRAM			
MODEL	AVR140, AVR140/230		
DESIGN	CHECK	APPROVE	DRAWING NO
LEE C B	Y.W.Y	L.H.W	1816SCMZ (VIDEO)
05.02.01			

# AVR140 WIRING DIAGRAM

USA : 120V 60Hz  
EUR : 230V 50Hz

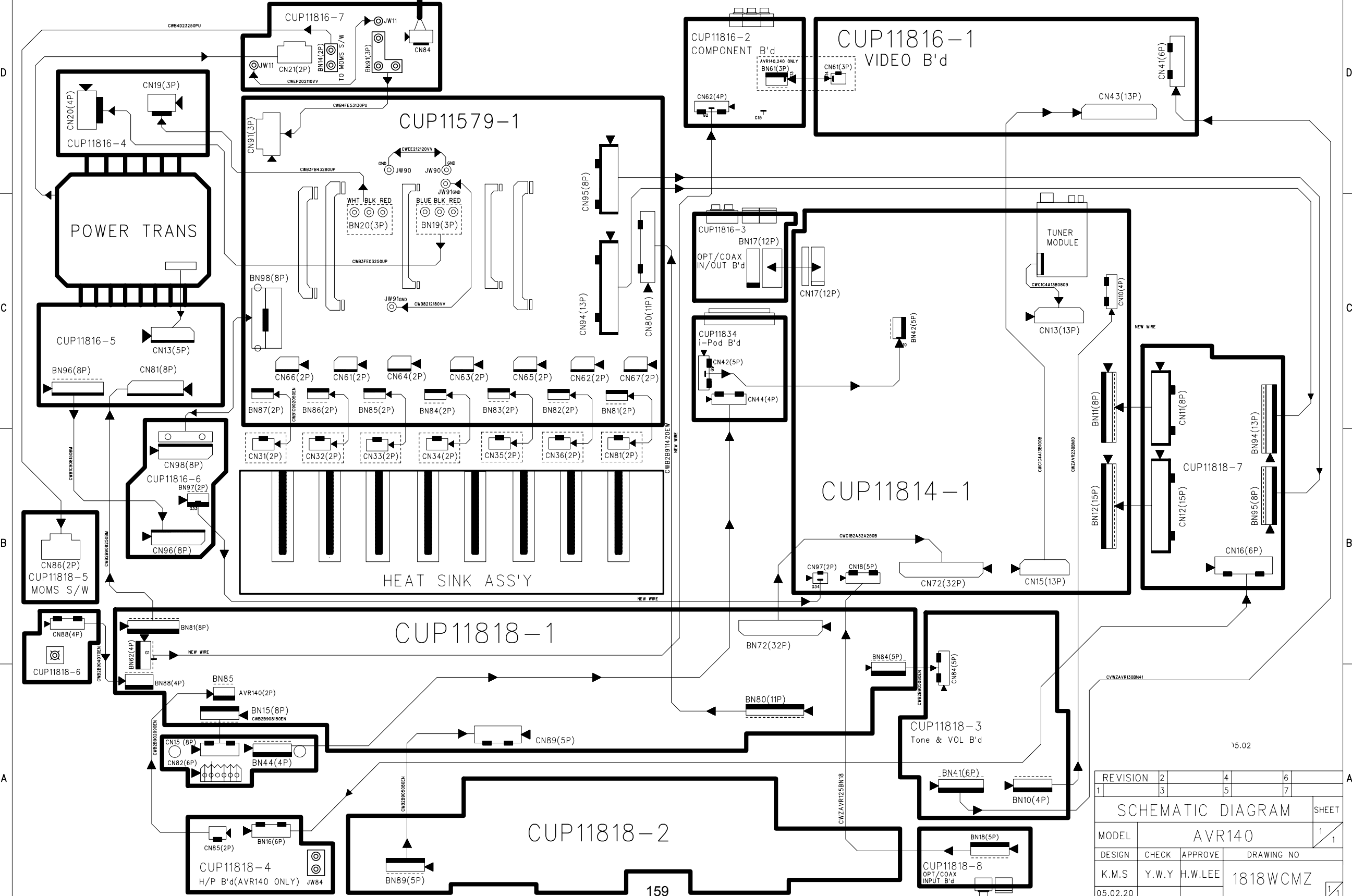

15.02

REVISION	2	4	6
1	3	5	7

SCHEMATIC DIAGRAM SHEET

MODEL	AVR140			1/1
DESIGN	CHECK	APPROVE	DRAWING NO	
K.M.S	Y.W.Y	H.W.LEE	1818WCMZ	
05.02.20				1/1